

5. Junctions and crossings

This chapter provides design guidance on the use and adaptation of junctions and crossings to form safer, coherent and comfortable cycling provision.

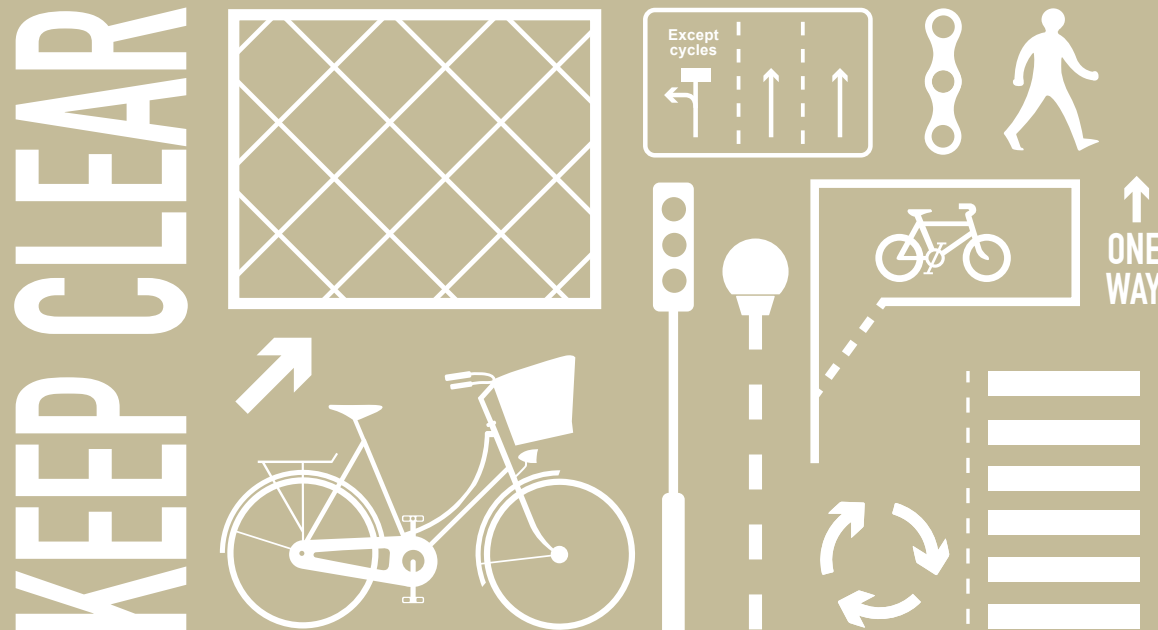

5.1	Junction design issues	01
5.1.1	User needs	01
5.1.2	Cycle-friendly interventions	02
5.1.3	Junction analysis	03
5.1.4	Corner radii	03
5.1.5	Visibility splays	05
5.2	Crossings	06
5.2.1	Crossing types	06
5.2.2	National guidance on crossings	07
5.2.3	Selecting the crossing type	08
5.2.4	Crossings at signal-controlled junctions	08
5.2.5	Shared/Toucan crossings	11
5.2.6	Priority crossings	12
5.2.7	Mid-link cycle-only priority crossing	15
5.2.8	Uncontrolled crossings and refuge islands	15
5.2.9	Informal crossings	18
5.2.10	Crossings of cycle lanes and tracks	18

Version control

Version 1 (Dec 2014) – Published

Version 2 (Sept 2016) – Minor amendments following publication of TSRGD (2016); minor updates to section on low-level cycle signals and ASLs

5. Junctions and crossings

5.3	Priority junctions	21
5.3.1	Cycle-friendly interventions	21
5.3.2	Road user behaviour	21
5.3.3	Cycle lanes at priority junctions	22
5.3.4	Segregated lanes/tracks at priority junctions	23
5.3.5	Cycling facilities across minor accesses	27
5.4	Signal-controlled junctions	28
5.4.1	Cycle-friendly interventions	28
5.4.2	Procedures for traffic signals	28
5.4.3	Traffic signals for cyclists	29
5.4.4	Cycle early release	32
5.4.5	'Hold the left turn'	32
5.4.6	Cycle gate	33
5.4.7	Two-stage right turn	34
5.4.8	Other methods of managing conflicts	38
5.4.9	Advanced stop lines	43

5.5	Roundabouts and gyratories	49
5.5.1	Cyclists' use of roundabouts	49
5.5.2	Roundabout types	49
5.5.3	Normal roundabouts	50
5.5.4	Mini-roundabouts	51
5.5.5	Compact and continental roundabouts	52
5.5.6	Roundabouts with segregated cycle lanes	53
5.5.7	Informal roundabouts	54
5.5.8	Gyratories and one-way systems	54
	Bibliography	56

5.1 Junction design issues

5.1.1 User needs

Junctions are where actual and perceived risk to cycle safety are highest, and usually represent the most uncomfortable parts of any journey for cyclists. Even where degree of separation on a link may not warrant being high, more separation may well be justified at junctions, both from motorised vehicles and pedestrians. As with links, all user needs must be taken into account (see section 3.2), particularly the movement of emergency service vehicles and pedestrians.

Key considerations include:

- Facilitating all cycle turning movements at any junction, including right turns and turns from nearside segregated cycle infrastructure
- Addressing left- and right-hook collision risk from turning motorised vehicles
- Designing for all types of cycle, including wider and longer models and those adapted for use by people with physical, sensory or cognitive impairments (likely to be significant for any protected area, any segregated approach to an ASL, any special arrangement for right-turns and any provision of gaps to enable turning movements)

Figure 5.1 Key junction considerations in CLoS

Factor	Indicator	Relates in this chapter to
Safety: Collision risk Feeling of safety	Left/right hook at junctions Other vehicle fails to give way or disobeys signals Separation from heavy traffic	Junction design: separation of cyclists in space and/or time, use of traffic signals, advanced stop lines (ASLs).
Directness: Journey time	Delay to cyclists at junction	Separation of cyclists from other vehicles while maintaining appropriate priority for cyclists. Long delays at signals will deter cycling and reduce compliance.
Directness: Value of time	Value of time	
Coherence: Connections	Ability to join/leave route safely and easily	Use of crossings, appropriate provision at priority junctions and cycle infrastructure at signal-controlled junctions to ensure all desired cycle movements are accommodated.
Attractiveness: Minimise street clutter	Signing required to support scheme layout	Avoiding over-complication in junction design, so that cycling infrastructure is consistent and intuitive.

Quality of provision for cyclists at junctions and crossings is covered by the Cycling Level of Service Assessment, as shown in figure 5.1. This, together with the junction assessment tool, is recommended as the measure for how safe, comfortable, direct, coherent, attractive and adaptable is the provision for cyclists at a junction. Adaptability is worth emphasising, given the need to plan for a growing number of cyclists, and evolution of practice through trial and experimentation.

5.1.2 Cycle-friendly interventions

Figure 5.2 indicates the ‘cycle friendliness’ of the types of intervention covered in this guidance, by way of providing an overview of the content of the chapter. Any of these interventions may be suitable for a given cycle route type – it is the place and movement characteristics of a location and the level of service for cyclists that dictate how appropriate or successful any given intervention might be. Where ‘+/-’ is shown, the intervention is likely to have some negative consequences for cyclists as well as benefits, depending on the context. Note that the table does not cover impact on other users.

Trialling junction improvements

Providing for cyclists at junctions is an area where trialling and learning from international practice have had, and will continue to have, a strong influence on design practice. Improvements made by TfL and the London boroughs at junctions and crossings represent an evolving body of practice, and ongoing monitoring and research carried out on such infrastructure schemes will continue to aid understanding of impacts and benefits, and inform future guidance.

Figure 5.2 Types of intervention at junctions

Technique	Intervention / impact on cycling level of service	
Exert more control over different vehicle movements	Separate signal control for cyclists (separation in time)	++
	Protection for cyclists from turning movements (separation in space)	++
	Conversion to cycle-friendly roundabout	+/-
	Ban selected movements for motorised vehicles	+/-
	Conversion of priority to signal-controlled junction	+/-
Allow more (low risk) interaction; reduce control	Reducing speeds on turning – corner radii, tables, raised entry treatments	++
	Change priorities (to favour selected cycle movement)	+
	Cycle bypass of traffic signals	+/-
	Convert signal-controlled to priority junction	+/-
	Provide lane markings through/past junction	+/-
	Remove all priority	+/-
Facilitate cycle turning movements	Enable right turns by cyclists in two stages	+
	Introduce a crossing and/or refuge islands to help cyclists to turn out or in	+/-
	Advanced stop lines	+/-

From 2012, TfL began working with DfT and other key stakeholders, including borough representatives, on a series of off-street trials at the Transport Research Laboratory (TRL) test track. Some interim findings from this research have fed into this document but some conclusions may not be available until 2015, and so will be incorporated into guidance at a later stage. Wherever possible, innovations in the trial stage have been highlighted in this chapter in anticipation of their eventual full inclusion in LCDS, subject to trial results.

5.1.3 Junction analysis

It is important for any junction improvement to be based on a comprehensive understanding of the place and movement functions of the location. Sources of information on this include:

- Collision history, showing locations, severity of injury and details of the circumstances
- Area-wide analysis: relationship between the junction in question and cycling routes, location of public transport stops, information about bus routes, the strategic importance of the streets, kerbside activity, motor traffic speeds
- Traffic flow data (including cycling), broken down by time of day and by mode, and traffic modelling
- Pedestrian flows, including trip generators and variation by time of day – this should include where crossings currently exist and show pedestrian desire lines

When considering cycle flows, it is important to note that certain cycle movements may be low because they are difficult and uncomfortable to make rather than because there is no demand for movement in that direction. If parallel, but less direct routes have high cycle flows, then a ‘junction avoidance’ effect may well be operating.

For any junction, greater numbers of traffic lanes generally make for more hostile cycling conditions. Simplifying junction layouts and reducing the amount of lane-changing that takes place on junction approaches can be of great benefit to cyclists.

The junction assessment tool (see section 2.2.5), or similar method of analysis, should be applied to any planned intervention, firstly to establish conflicts and cycling movements that are difficult or uncomfortable to make, and then to assess the extent to which a proposal addresses those issues. It is important, however, to keep in mind all desired outcomes: tackling a specific conflict issue could compromise another key outcome, such as directness (avoidance of delay) and may result in poor compliance and more risk taking.

Key conclusions that can be drawn from past research and from analysis of collisions include the following:

- ‘Some of the most significant benefits come from reducing motor vehicle speeds through reducing traffic lane widths,

taking out slip lanes and reducing corner radii’ (TRL, Infrastructure and Cyclist Safety PPR 580, 2011)

- ‘Behavioural factors are prominent, with the two most common contributory factors being “failed to look properly” and “failed to judge other person’s path or speed” – this indicates that infrastructure that influences road user behaviour generally may be more significant than interventions that seek to target specific safety issues’ (TfL, Pedal cyclist collisions and casualties in Greater London, 2011)

5.1.4 Corner radii

Relatively minor adjustments to junction geometry can have a significant effect on the speed of turning vehicles. The advantages to safety that arise from reducing speed need to be balanced against the need to provide adequate visibility and allow larger vehicles to turn.

Small corner radii, often used in conjunction with raised entry treatments or raised tables, can reduce the speed of turning traffic, help simplify tactile paving layouts and reduce crossing distances for pedestrians and cyclists. They are also of benefit to cyclists both on- and off-carriageway because they reduce the zone of risk. Unnecessarily large corner radii can encourage higher speeds by motorists and should be reduced where feasible, particularly at priority junctions and where there is an identified relationship with cyclists or pedestrian casualties.

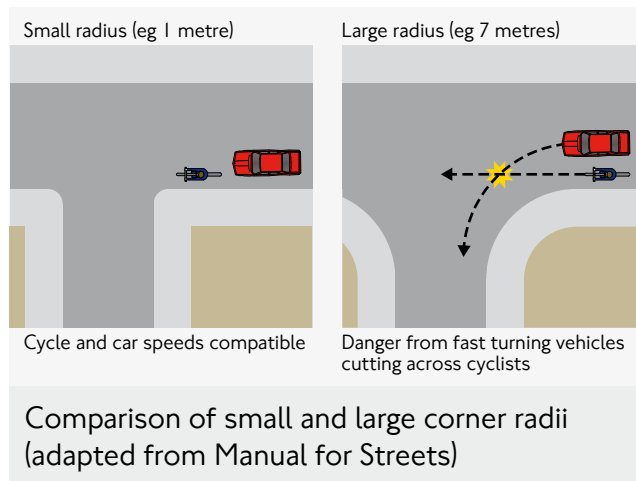

Many existing streets operate in a satisfactory way with minimal corner radii, even a kerb quadrant only. The most appropriate radius depends on site-specific conditions. Variables to take into account include:

- Motorised vehicle speeds
- Carriageway width and number of lanes (larger vehicles may straddle lanes to turn where there is more than one, thereby justifying a smaller radius)
- Traffic volume and composition (where many larger vehicles are turning, their ability to do so by moving out to turn may be constrained)
- Angle of intersection at junction (larger radius is likely to be needed for any turn through less than 90 degrees)

- Pedestrian crossing arrangements (two stage crossings require islands that may necessitate larger radii in order to allow turning movements by larger vehicles)
- Uphill or level gradients (rear-end shunts could be an issue downhill where turning vehicles may decelerate abruptly to turn)

Designers should start from the assumption that corner radii should be minimised to benefit vulnerable road users, and then test whether this raises any issues. Junction design and the size of corner radii need to support calming and speed reduction measures, as described in section 3.3. Indicative ranges of corner radii to support speed limits on the street in question are:

- 0-3 metres for 20mph speed limit
- 2-6 metres for 30mph
- 3-10 metres for more than 30mph

Tracking large vehicle movements

As part of the design process, swept path analysis should be used to track the paths of larger vehicles around corners (Manual for Streets, 6.3.13). It is usually acceptable for large vehicles to enter the opposing general traffic lane or adjacent with-flow lane in order to turn, provided there are no physical constraints to them doing so. There may need to be some local strengthening of the footway to allow for larger vehicles occasionally overrunning, although this is not generally desirable because of its impact on pedestrian safety and comfort.

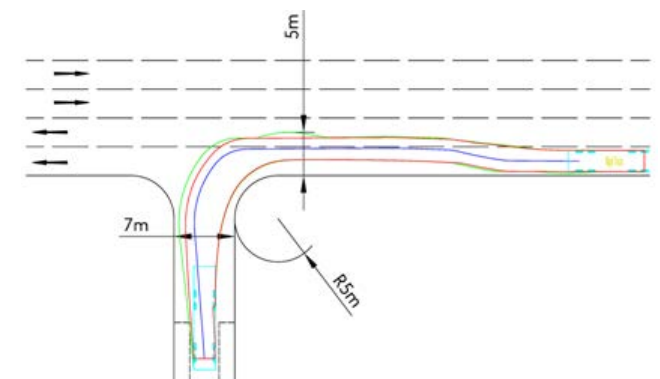

Swept path analysis

It is important not to design geometry solely based on occasional use by large vehicles, such as refuse or removal trucks. In all instances, the designer should take into account the individual site characteristics when choosing the appropriate corner radii. Provided drivers can make the turn within the overall road space available, it is rarely necessary to design so that they can do so while remaining entirely in a single nearside lane.

In most circumstances, the safety benefits to cyclists of tighter geometry and the slowing of motorised vehicle turning movements outweigh risks to cyclists that exist in relation to larger vehicles moving out to the centre of the carriageway or a different traffic lane to make a left turn. Turning vehicles should, according to Highway Code rule 183, give way to a nearside cycle lane, while cyclists should not seek to undertake at priority junctions where any

possibility exists that a vehicle may be turning left. A risk assessment on a given site should be undertaken to identify the risk of larger vehicles turning well away from the nearside and to examine whether other mitigating measures (such as further speed reduction techniques or banning turns) might be of more general benefit.

5.1.5 Visibility splays

Any change to junction geometry should also take into account the impact on sight-lines, which are needed to ensure adequate visibility at junctions. Conformity with Manual for Streets guidance is recommended:

- For side roads, the minimum 2.4 metres 'X' distance should be used – allowing full visibility for the driver of an emerging vehicle without needing to cross the give way markings
- In low flow situations, 2.0 metres may be acceptable, although it is likely to require some protrusion into the main carriageway
- Where traffic speeds are already low, or have the potential to be substantially lowered, and where shorter 'Y' distances would not pose a significant risk at such a junction, reducing forward visibility might have a further calming effect, as is described in Manual for Streets.

Reducing visibility should not compromise cycle safety at priority junctions and a risk assessment should be undertaken to check whether reduced 'Y' distances and tighter geometry generally are acceptable from a cycling perspective. There may, for example, be occasions where horizontal deviations to improve cyclists' sight lines or speed humps should be added on the approach to a crossing, junction or shared-use area.

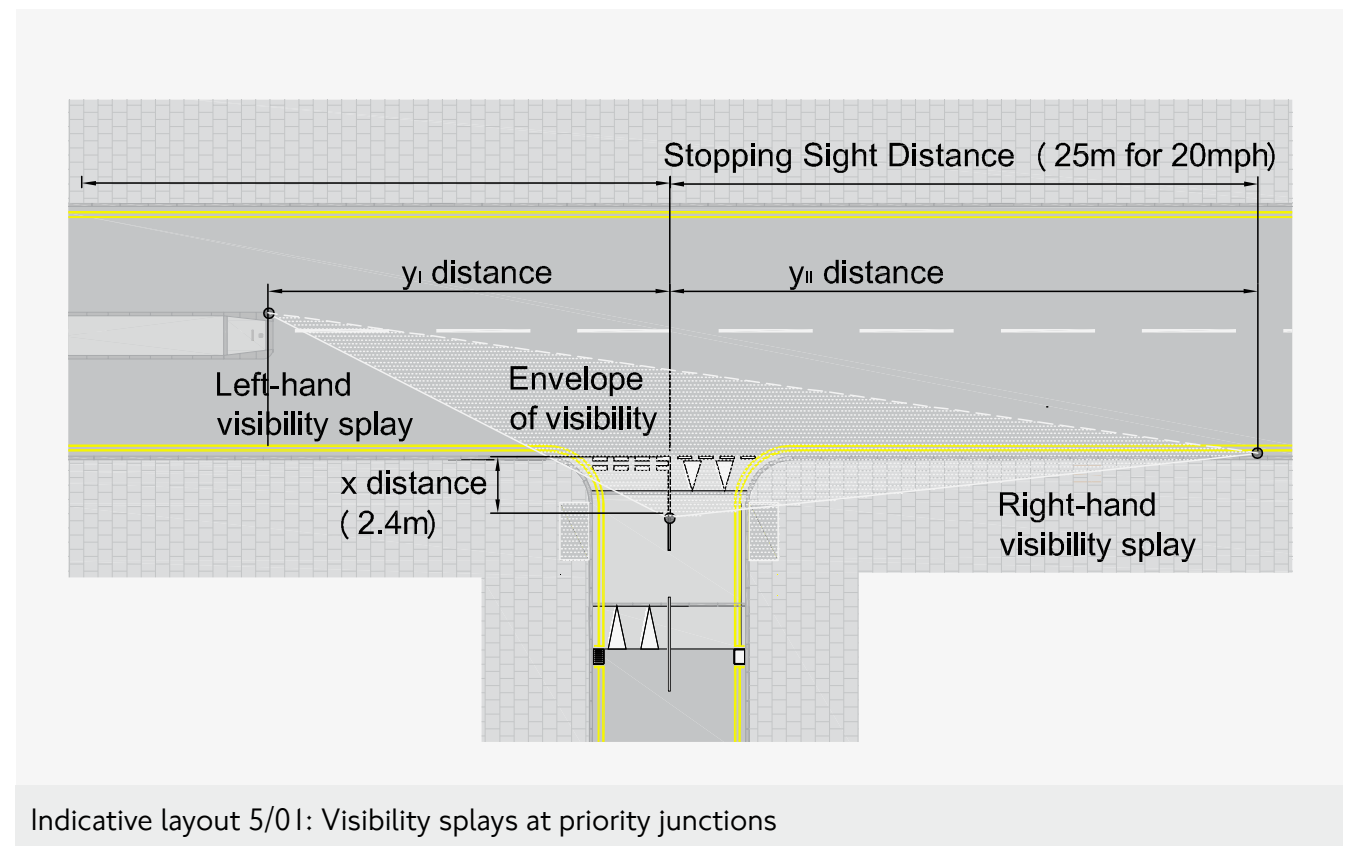

5.2 Crossings

5.2.1 Crossing types

Crossings are a significant part of the cycling network in London for three quite different reasons:

- Crossings that cyclists can use are important for safely negotiating roads with high movement function, for linking cycle routes and for giving coherence to cycling networks. The type and location of these crossings has a bearing on the directness, coherence, comfort and safety of cycling provision
- Crossings can occasionally act as a traffic calming measure and contribute to generating gaps in traffic flow that cyclists can use to turn from minor roads to major roads and vice-versa. So, even where a cyclist cannot use or is unlikely to use a given crossing, it can still contribute to their level of service
- Pedestrian crossings of cycle facilities, whether part of the main carriageway or elsewhere, need to be planned to maximise accessibility and to avoid excluding vulnerable pedestrians when introducing certain types of cycle infrastructure

Crossings over carriageways with the potential for cycle use may be categorised into six types, as shown in figure 5.3. Refer to TfL’s London Pedestrian Design Guidance for more detail on crossing types.

Figure 5.3 Cycle and pedestrian crossings over general traffic lanes

	Junctions under signal control	Stand-alone locations
Crossings that may be used by cyclists	[1] Parallel pedestrian/cycle ** [3] Shared pedestrian/cycle	[2] Signal-controlled cycle-only [3] Signal-controlled shared (ie toucan) [4] Priority (parallel) pedestrian/cycle *** [5] Mid-link cycle priority [6] Uncontrolled / informal
No cycling*	Pedestrian-only	Signal-controlled pedestrian-only (pelican, puffin)

Notes

* While these types do not allow cyclists to use the crossing, they can support nearby cycle movements in instances where the cycle desire line is offset from the crossing, as described above.

**At a stand-alone location, signal-controlled parallel cycle and pedestrian crossings would require conversion to a junction so this is, in effect, type [1].

***Type [4] has been available since the publication of TSRGD (2016). It is preferred to type [3] in any situation where at least one of the two facilities that it links has separate provision for pedestrians and cyclists

For the purposes of this guidance, stand-alone toucan crossings and shared pedestrian and cycle crossings at signal-controlled junctions are dealt with as a single type – type [3] – although there are technical and operational differences between them.

5.2.2 National guidance on crossings

The Traffic Signs Regulations and General Directions (TSRGD, 2016) provides the regulatory framework for crossings, superseding the Zebra, Pelican and Puffin Pedestrian Crossings Regulations and General Directions (1997). Further advice and guidance is provided by DfT in LTNI/95, Assessment of Pedestrian Crossings, LTN 2/95, Design of Pedestrian Crossings, TAL5/05 Pedestrian facilities at signal-controlled junctions and Signing The Way (2011).

Reference should also be made to Guidance on the use of tactile paving surfaces, which describes requirements for accessible crossings – key advice from this is summarised in section 7.3.3.

All crossings should be step-free, which can be achieved either through dropped kerbs or by placing crossings on a raised table or entry treatment. There may also be advantages for people with visual impairments or lowered vision in using a surface material for the crossing that has a strong tonal contrast with the carriageway (see section 7.3). Relevant streetscape and local design guidance should be consulted for advice about materials.



Crossing on a raised table and with contrasting surface treatment, Waterden Road, Hackney



Wide crossing, consisting of two parallel stand-alone, signal-controlled crossings, with contrasting surface treatment, St Paul's Churchyard, City of London

5.2.3 Selecting the crossing type

For a cycle route crossing a carriageway, the most appropriate crossing choice generally depends on the traffic conditions of the street – indicative flows by crossing type are shown in figure 5.4. Since signals are expensive to install, operate and maintain and tend to have a negative impact on the street environment, good alternatives to signalisation should always be explored. For that reason, types [4] to [6] are generally recommended for lower-intervention Quietways and other local routes, although new signals may be needed in some locations, particularly to help cyclists cross busy roads.

The appropriate crossing option for a given location also depends on the character of the place in question and considerations of street clutter and accessibility. Type [6], an uncontrolled crossing, is the ‘lowest intervention’ form and likely to be fit-for-purpose only with relatively low levels of use by those crossing and where traffic speeds and volumes are low enough to allow safe opportunities for crossing.

Figure 5.4 Cycle crossing options

Type of crossing	Flows (24hr)		
	All vehicles (carriageway)	Cycles (crossing)	Pedestrians (crossing)
1. Parallel signal-controlled pedestrian/cycle	> 8,000	Medium-High	Medium-High
2. Signal-controlled cycle-only	> 8,000	Medium-High	None
3. Shared pedestrian/cycle or toucan	> 8,000	Low-Medium	Low-Medium
4. Priority pedestrian/cycle (parallel)	3,000-8,000	Medium	Low-Medium
5. Mid-link cycle priority	3,000-8,000	Low to Medium	n/a
6. Uncontrolled (central refuge)	3,000-8,000	Low	Low

5.2.4 Crossings at signal-controlled junctions

Cycle tracks may be joined across one arm of a junction under signal control by using types [1], [2] or [3].

Type [1] is recommended where there is high demand by both cyclists and pedestrians, thus reducing potential conflicts between the two modes on the crossing. This may be particularly useful where cyclists are approaching from a different direction from pedestrians, as is often the case when one route is a side street closed to motor traffic.

Type [2] is a variant where there is no parallel pedestrian crossing facility. For this type, reliable cycle detection should be used so that demand can be prioritised and delay minimised. Where the cycle crossing cannot align with the cycle route in a way that allows cyclists to remain on carriageway, a shared use area will be required to allow access to the crossing.

Type [3] is less desirable from a pedestrian and cycle level of service perspective, but may be needed where the crossing joins shared use facilities on either side, or where it is impossible to separate cycle and pedestrian movement because their desire lines intersect.



Type [1]: parallel crossings at Westferry and West India Dock Road. Ladder and tramline tactile paving are used for transition from track to shared area

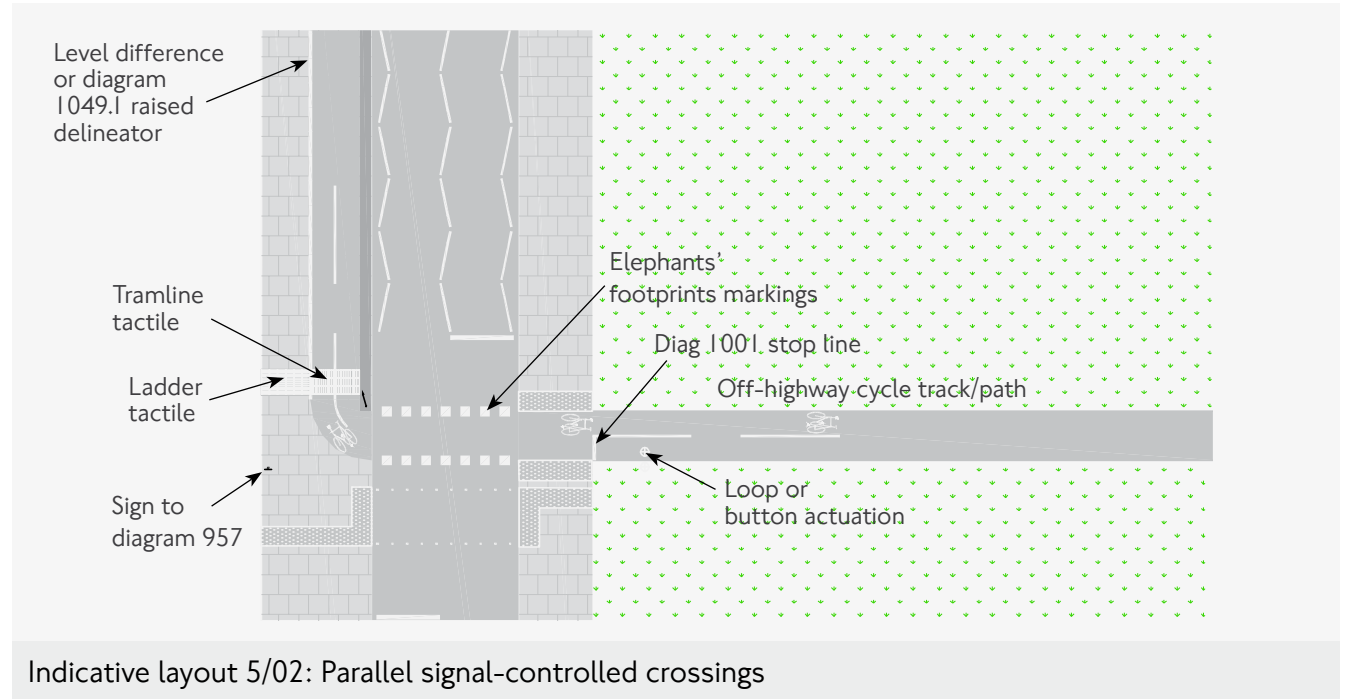

Square elephants' footprints markings, to TSRGD diagram 1055.3, are recommended for both type [1] and [2] crossings, although pedestrian crossing studs are also sometimes used for this purpose. Elephants' footprints to mark a cycle route at a crossing under signal control or as part of a parallel priority crossing are prescribed in TSRGD (2016) and therefore no longer need site-specific approval. This should add consistency and will bring the UK into line with other parts of Europe on use of a square-format marking for cycle crossings.

Transitions to and from carriageway

Consideration should be given to how cyclists join and leave such crossings – how cycle movement on the tracks or shared use paths may join cycle movement on the main carriageway.

Certain arrangements may put cyclists in conflict with pedestrians on, or waiting at, the crossing. Layout and design of signal control should avoid encouraging cyclists to move through the crossing area during the pedestrian green phase.

This is simpler to achieve with shared use arrangements, where a dropped kerb ahead of the crossing may allow cyclists to make a clear transition from on- to off-carriageway, and then to wait with pedestrians. See example illustrated in chapter 5, page 37.



Type [2]: stand-alone cycle crossing at Goswell Road



Signal-controlled cycle crossings, using elephant's footprint markings through the junction

Cycle gaps

At some signal-controlled locations, providing cycle gaps through islands may be more appropriate than marking elephant's footprints across the carriageway. It can be helpful to use 'Keep Clear' or yellow box markings so that queuing traffic on the carriageway does not block the crossing. Providing such markings needs to be balanced with impact on other users and on the street scene. They should only be used in exceptional circumstances.

5.2.5 Shared/Toucan crossings

Crossings shared between pedestrians and cyclists at stand-alone signals (type [3] in figure 5.4 above) are toucan crossings. As part of signal-controlled junctions, the design issues are similar. In a toucan crossing, the surface of the crossing and footway areas immediately on either side are shared, although there may be some separation of the footway up to that point. If there is separation on either or both sides, then the parallel crossing should be used instead of a toucan.



Because of this sharing, and the impact on the comfort and sense of safety of vulnerable pedestrians, toucan crossings and associated shared use footways are not generally recommended unless it has been properly established that there are no better alternatives.



Cycle gaps

Variants to the standard toucan layout are possible for locations such as side road junctions that can enable more direct crossings. The DfT provides guidance in TAL 10/93, Toucan: an unsegregated crossing for pedestrians and cyclists and in TAL 4/98, Toucan crossing development.



Toucan crossings are often used to carry off-carriageway tracks through or around junctions



Typical toucan crossing arrangements, with shared use and tracks on either side (colour optional)



Nearside push-button control for toucan crossing

5.2.6 Priority crossings

Since the publication of TSRGD (2016), a new crossing type has been available, allowing for parallel pedestrian and cycle crossings without the need for signal control. This priority crossing is similar in appearance to a zebra crossing but with a parallel route for cyclists, marked with diagram 1055.3 'elephants' footprints' within the controlled area of the crossing.

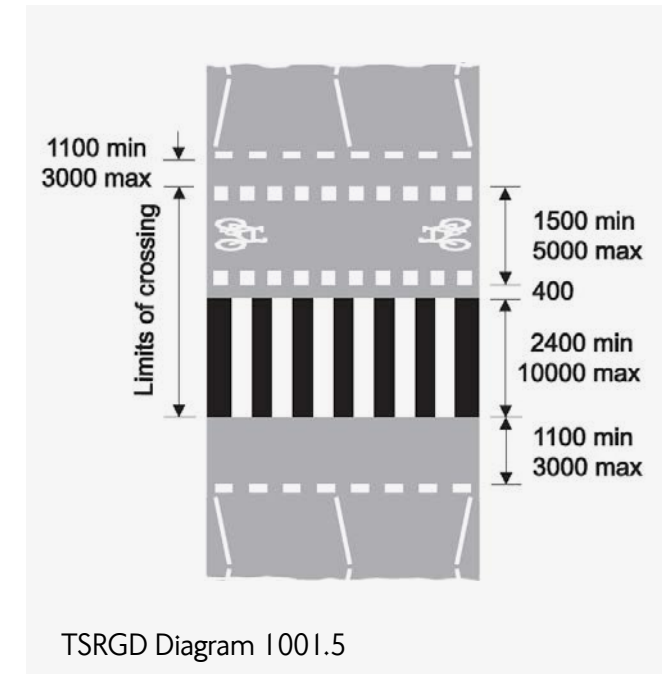



The case for parallel priority crossings. In the UK (left), regulations have not previously allowed for a parallel cycle route at a priority crossing – cyclists are asked to give way twice. A much simpler approach exists in Stockholm, right, where cycle crossings with elephants' footprints are provided within the controlled area of the 'zebra-type' priority crossing.

Transitions

As with the signalised equivalent, careful consideration is needed of cycle transitions between the crossing and the main carriageway in order to minimise conflict between cyclists and crossing pedestrians.

However, design of transitions (and other conditions likely to arise) depends on details yet to be established in regulations and practice. For example, two sets of elephants' footprints markings on one crossing, should it be permitted, could help clarify cycle movements and reduce conflict.

Design of areas either side of the crossing is important. Ideally, the crossing should be used where cyclists and pedestrians have separate provision on both sides and where cyclists can be kept separate throughout. Although less desirable, the parallel crossing is likely to be preferable to the toucan crossing where only one side is separate and the other shared. The crossing should not, however, be used to link one shared use facility with another.

Cyclists' use of shared priority crossings

A priority crossing type shared between cyclists and pedestrians may be a further possibility for inclusion in the regulations. This would effectively be a version of the zebra crossing that would allow cyclists to cross with pedestrians, which is desirable because the legal position on cyclists' use of zebra crossings is such that it is not recommended that they be planned and designed for use as part of the cycle network.

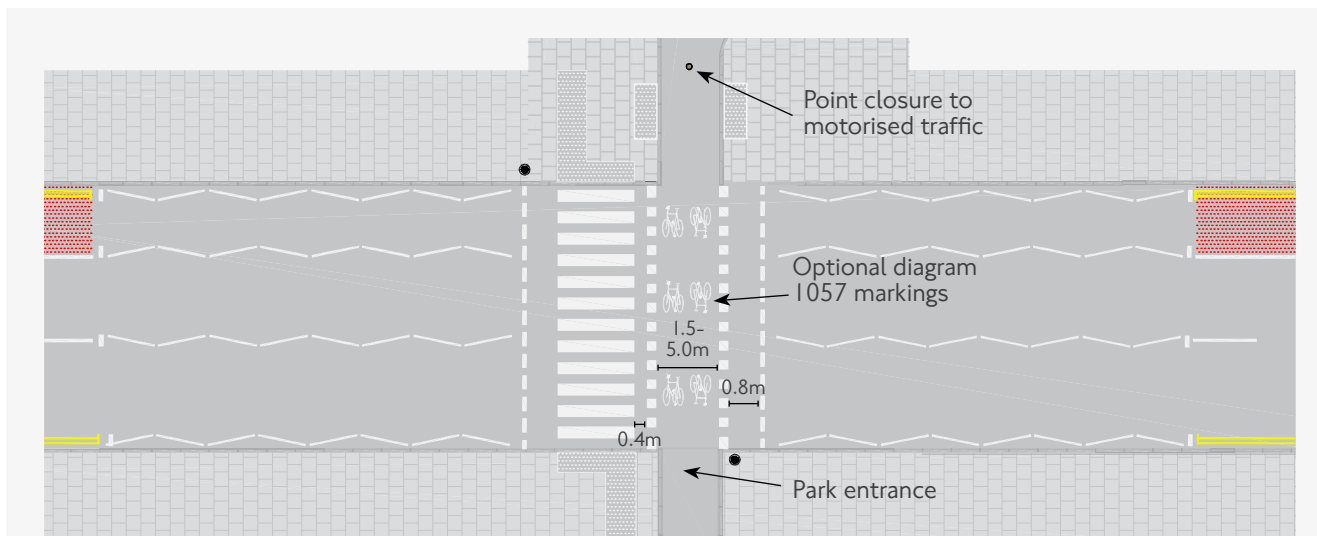

Indicative layout 5/03: Parallel priority crossings

TfL's position, drawing on conclusions from TrL's Shared Zebra Crossing Study (2006), is that it is not illegal for cyclists to ride over zebra crossings. However, while the markings give pedestrians formal priority over traffic using the carriageway, this priority is not afforded to cyclists. Highway authorities should take legal advice if they wish to use zebra crossings to link cycle provision (tracks or shared use footway) on either side of a carriageway.

Cycle provision through zebra crossings

Where a zebra crossing is marked across a street with a cycle lane, the lane markings may not be continued through the zig-zag markings that show the controlled area of the crossing. However, TSRGD (2016) allows for the zig-zags to be moved away from the kerbside by up to 2 metres to align with the cycle lane markings and allow for greater visual continuity of the cycle facility. Diagram 1057 cycle symbols may be placed between the zig-zags and the kerb in this instance, but no other markings are permitted.

By exception, the number of zig-zag markings may be reduced from eight to two, depending on site-specific conditions such as visibility and the existence of other parking controls. Where the number of zig-zags is reduced, it may be advisable to widen the crossing, especially where the approach is not straight. For carriageway widths of 6 metres or less, the central set of zig-zags may be omitted.

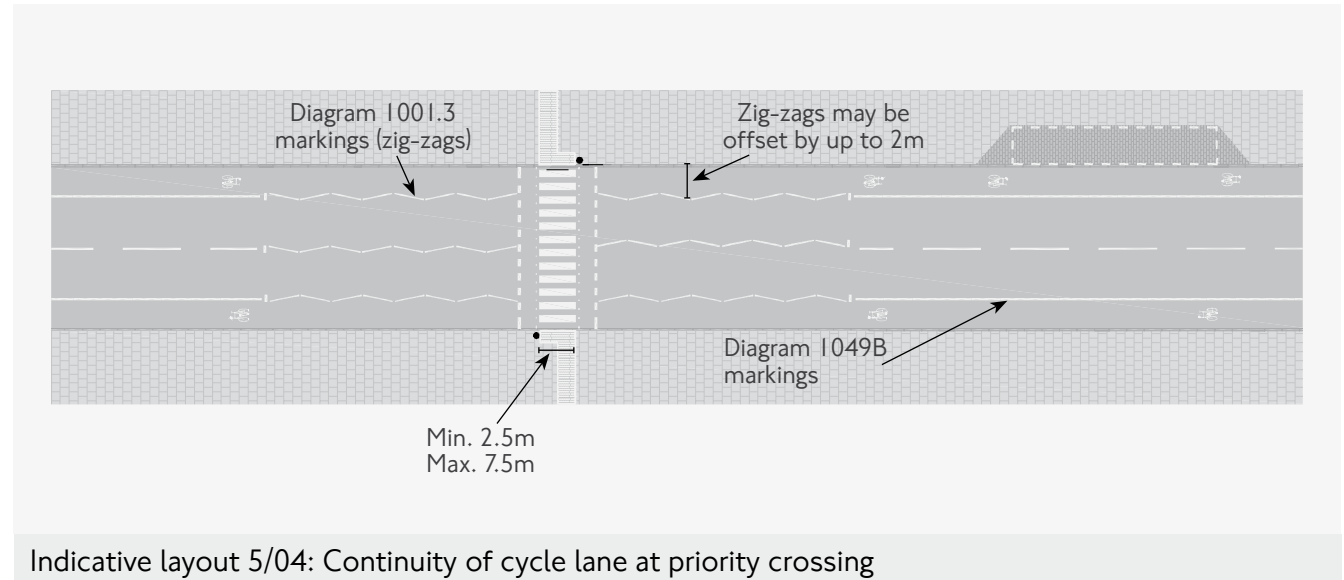

5.2.7 Mid-link cycle-only priority crossing

Where a cycle track crosses a road, it is possible to give it priority on a hump using a layout shown in LTN 2/08, Cycle Infrastructure Design. Its applicability is likely to be limited to scenarios where there is no pedestrian provision on or

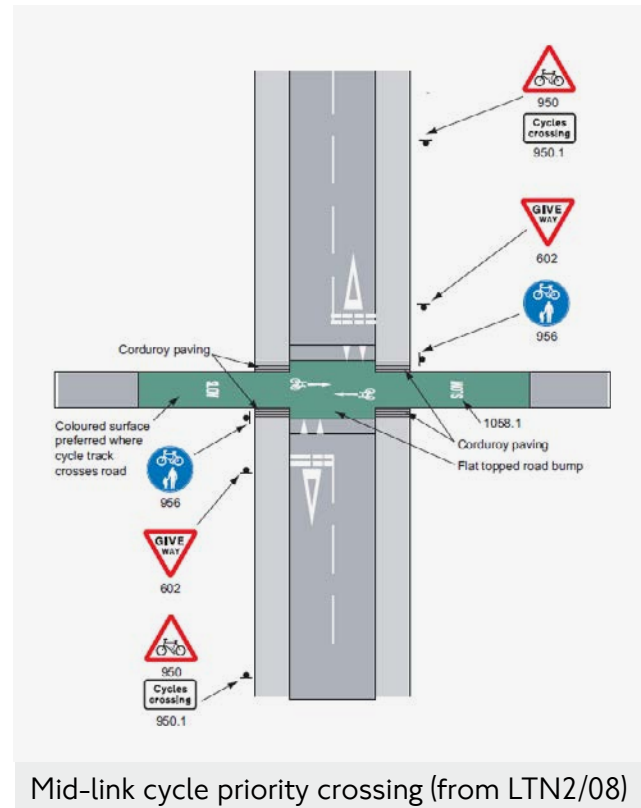

Mid-link cycle priority crossing (from LTN2/08)

beside the track and no case for providing a crossing type that would allow pedestrians and cyclists to cross.

LTN2/08 gives a number of further caveats about this arrangement, emphasising the need for all of the signing shown on the diagram in order to mitigate the risk of motorists not giving way where the road markings instruct them to. The importance of good visibility is also highlighted.

5.2.8 Uncontrolled crossings and refuge islands

Some locations are marked for crossing without any formal control of traffic on the carriageway – generally on less heavily trafficked streets with a single lane in either direction.

These uncontrolled crossings are step-free (either through use of a dropped kerb or raised table) and usually marked with an 800mm strip of blister tactile paving.

They often include refuge islands to enable crossing of each half of the road separately. The island should be at least 2.0 metres deep to allow a person in a wheelchair or with a pram to use it safely. See TfL's London Pedestrian Design Guidance for full details of these types.

These crossings can either facilitate a conventional crossing movement, helping cyclists make direct links between facilities on either side of the road, or enable difficult turning movements to be made in more than one stage.



Uncontrolled crossing and refuge islands ('look left' and 'look right' markings not normally needed)

Islands on a main road near to the mouth of a priority junction, for example, can help provide some refuge space for cyclists seeking to turn in or out. Cyclists can cross half of the carriageway and then wait in the shadow of the island to enter the traffic at a convenient moment. Care is needed when designing such an arrangement to avoid encouraging cyclists, particularly users of longer or wider cycles, to wait in locations where they are vulnerable to vehicle turning movements.

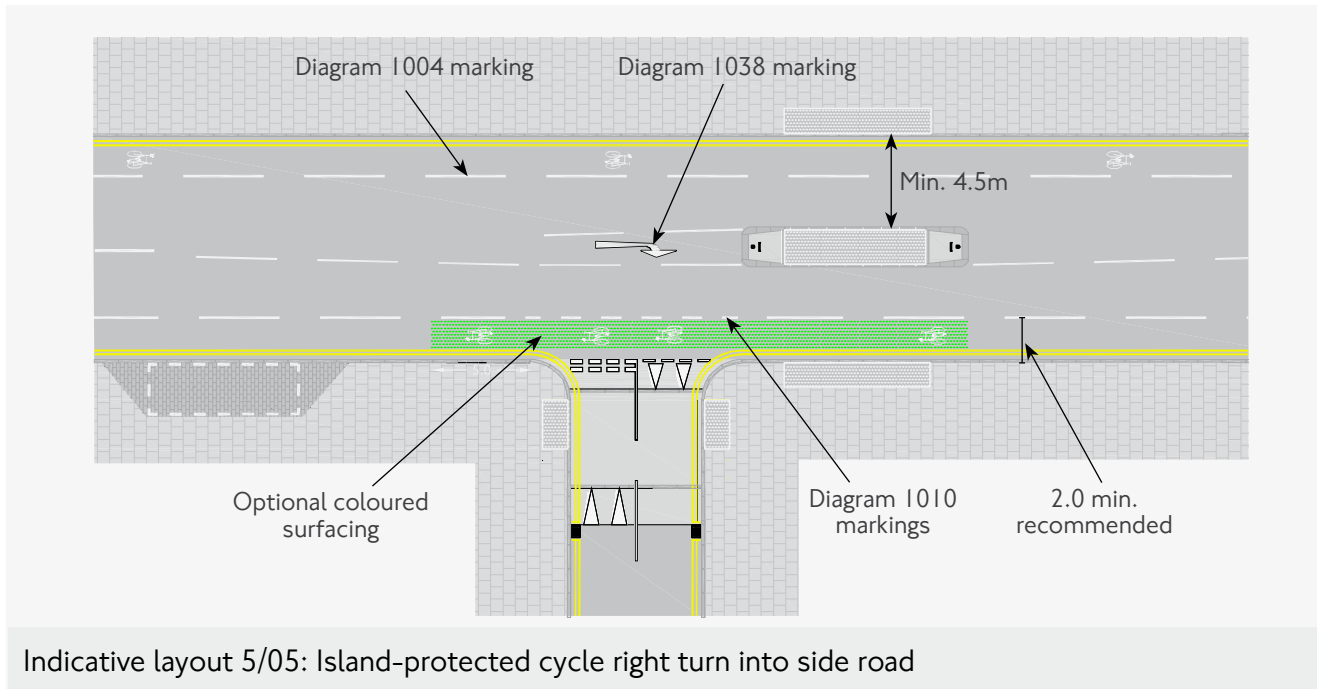

Avoiding pinch points

Although not a technique that greatly increases level of service for cyclists, providing islands to protect a turning movement can be beneficial, provided it does not create pinch points for cyclists using the carriageway – see guidance on widths in figure 5.5 below. Some speed reduction measures on the carriageway will also be necessary either in a scenario where the island narrows the lane below 3.2 metres wide or where the lane width remains over 3.9 metres. The impact on other road users of significant narrowing over a long stretch also needs to be assessed, particularly for emergency service vehicles.

Where cycle lanes on the carriageway can be continued past a pedestrian refuge island and still meet the width requirements set out in section 4.4.1, then they should be retained. Where such consistency cannot be achieved, then it may be desirable to replace an informal crossing with a formal pedestrian crossing and achieve consistently wider cycle lanes.



Pedestrian refuge island assists cycle right turn

Figure 5.5 One-way lane widths at refuge islands where no cycle lane, track or bypass is provided

85th percentile traffic speed	Traffic calmed, no buses or HGVs	No calming, no buses, HGVs etc.	No calming, with buses, HGVs etc.
< 20 mph	<2.5m	<2.5m or 4.0m+	3.0m-3.2m or 4.5m+
21 – 30 mph	4.0m+	4.0m+	4.5m+
> 30 mph	-	4.0m+	4.5m+

Cycle bypasses

An alternative is to design a bypass to a pinch-point. This should avoid deviating cyclists or creating conflict with pedestrians, and must be accessible to users of all types of cycle. Any vertical change required for use of the bypass by cyclists should not exceed 1:10, transitions should be smooth and step-free and a minimum width of 1.5 metres between obstructions should be provided.

The bypass should be designed to prevent blocking of the entrance and exit by other vehicles, which may require waiting and loading controls but preferably should be done without relying on enforcement. The facility must be designed so that cyclists can rejoin the carriageway without giving way.



Cycle bypasses used as part of traffic calming measures – note that blank bollards should be used rather than the 'keep right' sign, which would not allow cyclists to pass to the left

5.2.9 Informal crossings

In many other 'informal crossing' locations, pedestrians use islands and median strips in the carriageway to cross in multiple steps, even where those islands were not intended for that purpose. A more deliberate informal approach may be taken, using materials and streetscape features to 'suggest' that a crossing facility exists. This encourages drivers to slow down through the space and give way as necessary to anyone wanting to cross. These facilities do not confer any priority on the user seeking to cross, but can have a positive influence on driver behaviour.

5.2.10 Crossings of cycle lanes and tracks

For segregated and light segregated lanes, pedestrian crossings should preferably extend from footway to footway. In that way, the cycling facility is included within the controlled area of the crossing. Crossing times must be calculated to take into account the combined width of general traffic and cycle lanes.



'Suggested' crossing places in high street environments in Bexleyheath (above) and Hornchurch (right), using streetscape features such as raised tables, median strips, planting and a distinctive palette of materials to help break down dominance of the environment by motorised vehicles



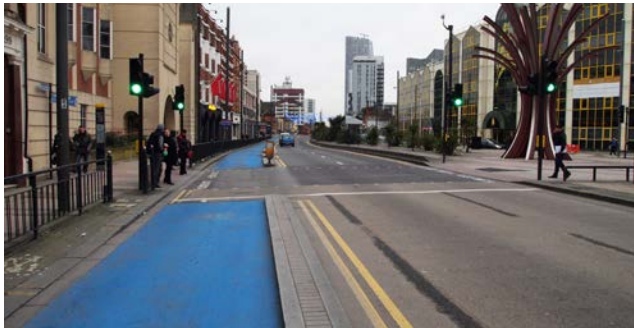

Crossing extending over carriageway and cycle lane



Uncontrolled pedestrian crossing of cycle tracks (at a bus stop bypass)

For stand-alone pedestrian crossing of cycle tracks, the basic options are:

- **Uncontrolled crossing**

As with uncontrolled crossing of the main carriageway, this consists of a dropped kerb, or raised table or hump, with appropriate blister tactile paving. Further signing may be added to promote courteous behaviour, and additional cycle speed calming measures may be appropriate (see section 4.5.1.6). Contrasting tone and surface material may be considered, to support legibility by people with low vision

- **Signal-controlled crossing**

This is not generally recommended unless as part of a larger junction. Blister tactile and tactile tails are required

- **Zebra crossing**

As established in TSRGD (2016), a conventional zebra crossing may be applied to

a cycle track and give priority to pedestrians crossing. Used in this way, the zebra crossing does not require zig-zag markings and belisha beacons are optional. Blister tactile, including tactile tails, is required to help people with visual impairments to find the crossing. Where the crossing is on a hump, then the Highways (Road Humps) Regulations 1999 apply, meaning that the crossing must be centred on the hump.

Tactile paving requirements for crossings are summarised in section 7.3.3.



'Mini zebra crossing' over a cycle track, Stockholm



Pedestrian crossing over a cycle track in Seville, with extra warning for cyclists

Pedestrian accessibility

In deciding between these options, the most important considerations are step-free access and the legibility of the environment for people with visual impairments and those with low vision. Depending on the context, crossing a cycle track may be an unfamiliar arrangement, particularly when parallel to another carriageway, and so it is important that the design of any crossing enables people to find the crossing point and use it in safety and comfort. Whether cycle traffic on the track is one-way or two-way will also have an effect on pedestrian comfort and accessibility, with more control likely to be necessary for two-way tracks.

Additional signs and markings, both to alert pedestrians to the existence of the cycle track and to encourage slower cycling, may be considered. These techniques are often found in other European countries where pedestrian crossings are marked over cycle tracks.

Combined crossing of main carriageway and cycle track

Where a pedestrian crossing over a cycle track is provided at the same location as a crossing of the main carriageway, the options are:

- Uncontrolled crossing of both cycle track and main carriageway. These crossings may be aligned or staggered

- Uncontrolled pedestrian crossing of the cycle track, and priority (zebra) or signal-controlled crossing of the main carriageway. Crossings must be staggered
- Priority pedestrian crossing of the cycle track, and priority or signal-controlled crossing of the main carriageway. Crossings should be staggered other than in the case of two zebra crossings, which can be aligned provided they are separated by an island of at least 2 metres' width
- Both crossings under signal control, which may be needed for high flows of both user. The preference is for pedestrians to cross in one stage, with crossings aligned. Separate signal control of the cycle track and main carriageway crossings, which would need to be staggered, is not generally recommended unless there are no other alternatives, given the delay to pedestrians that this would introduce and the unintuitive arrangement it would set up

Where a stagger is required, it is recommended that 2 metres is sufficient. The width of the island should be a minimum of 2.5 metres.

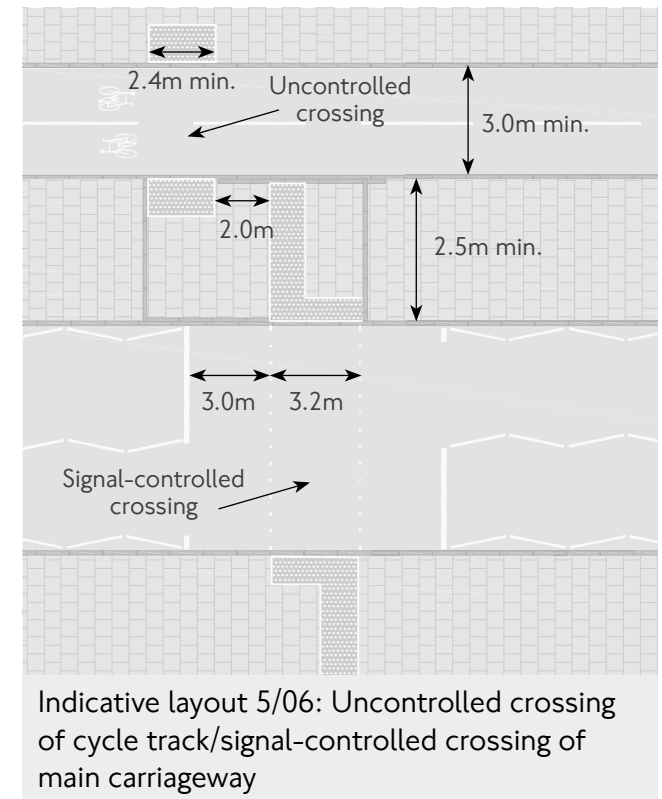

5.3 Priority junctions

5.3.1 Cycle-friendly interventions

The majority of highway junctions are of the ‘priority’ type – crossroads and T-junctions – where vehicle priority is given to traffic on the major road. The priority is usually indicated by give-way or stop-lines and associated signs. In some cases no road markings may be considered to be necessary where vehicle speeds and flows are low.

For cyclists, key issues relate to the safety and comfort of moving ahead through a priority junction while motorised traffic seeks to turn in or out, and the safety, comfort and directness of cycle turns into and out of junctions. Any turn for cyclists that involves moving across more than one lane of motorised traffic in one step is likely to be uncomfortable for most users. In all cases, speed reduction on the link and on turning are recommended as measures that increase level of service for cyclists but are also beneficial for pedestrians – particularly raised entry treatments and reduced corner radii.

5.3.2 Road user behaviour

Cycle lanes and tracks should enjoy priority over turning traffic. This is essential not just for directness and continuity, but also safety. A high proportion of collisions involving cyclists arise from motor vehicles turning across cyclists,

Figure 5.6 Summary of options for cycle-friendly interventions at priority junctions

Reduce speed on link	Speed reduction generally is recommended. Changes to geometry that can support this include: raised tables, kerb realignment, reduced corner radii, reduced width of junction mouth and footway build-outs. (See chapter 3)
Reduce speed on turning	Selective use of raised entry treatments can address common risks on turning and suggest visual priority for cyclists and pedestrians. Preventing or restricting parking and loading close to the junction is an important supporting measure in most cases, helping to maintain good visibility. (See chapter 3)
Change or reverse priority/ Ban specific movements	If made to benefit a route well used by cyclists, changing priority can help address specific conflicts between turning motorised vehicles and cyclists and enhance the directness, safety and comfort of a cycle route. Such interventions need to be part of a wider traffic management approach.
Convert to signalised junction	Justification for this would need to be made in the manner described in TfL’s Design standards for signal schemes, SQA064 (2014). (See section 5.4.2)
Introduce new crossing or refuge island(s)	If provided near the priority junction, these can support cycle turning movements, but only where avoiding the creation of pinch-points with unacceptable widths, and only in conjunction with other interventions to calm traffic speeds. (See section 5.2.8)
Road markings through junction	Visual priority can be supported by a combination of: TSRGD diagram 1057 cycle symbols, dashed diagram 1010 markings across the mouth of the junction and coloured surfacing. These interventions raise road user awareness of the presence and legitimacy of cycling and specific cycle movements.

either through failing to see a cyclist or failing to observe good practice on road user behaviour and priority as set out in the Highway Code (rule 183): ‘When turning, give way to any vehicles using a bus lane, cycle lane or tramway from either direction’.

Methods for giving unambiguous priority provided by UK regulations are limited in scope (which is a key difference between the UK and countries that operate a legal requirement for turning traffic to give way to ahead movement on its nearside) and so ‘suggested’ visual priority through design is an important tool.

5.3.3 Cycle lanes at priority junctions

Several different strategies are available to highlight to other road users the movement of cyclists, and the need to give way to ahead movement in the nearside lane (as the Highway Code recommends).

- Widening the cycle lane
- Providing a buffer space of 0.5 metres or more between the give way (TSRGD diagram 1003) markings at the side road and the cycle lane
- Continuing the lane marking across the side road using a short, dashed diagram 1010 marking – these are edge-of-carriageway markings and so do not mean ‘give way’ but are recognised as lines that should not be crossed without due care (see section 6.2.2)
- Using surface colour to highlight the potential conflict (see section 6.2.6)
- Using diagram 1057 markings to highlight the cycling facility (see section 6.2.5)
- Minimising corner radii and providing raised entry treatments to slow turning vehicles (see sections 5.1.4 and 3.5.2)

As these suggest, visual cues can encourage motorists to slow and/or be more aware of the presence of cyclists before turning.



Buffer between lane and give way markings, and use of colour



Dashed markings and coloured surfacing used for cycle lane

is also supportive of cycle lanes continued through junctions.



Dashed lane markings continued past side road with raised entry treatment

Diagram 1010 markings

The 1000mm-long diagram 1010 marking, a shorter dash than the 4000mm-long advisory cycle lane marking, should be used for lanes through junctions. This gives all road users a visual indication of a change in hazard associated with the junction. Use of the diagram 1010 marking for this purpose was established in TSRGD (2016).

DfT's Signing the Way (2011) cites qualitative research with cyclists to support the desirability of using lane markings through junctions from a cycle safety perspective. (AECOM, Traffic Signs Policy Review: Research Project into the Awareness of the Meaning of Traffic Signs Project PPRO 04/16/24, 2011) The TRL report for DfT Infrastructure and Cyclist Safety (PPR 580, 2011)

Cycle symbols

On streets without cycle lanes, TSRGD diagram 1057 cycle symbols may be used across junctions and accesses. These are usually positioned at the points where a cyclist should enter and exit from the side road and, in that way, help to guide appropriate cyclist positioning, as well as alerting other road users to the presence of cyclists. They remove any need for other warning signs to diagrams 962.1 (cycle lane) or 963.1 (cycle lane – look right) except for situations where contra-flow cycling is permitted.

Impact on riding position

In all instances, analysis of cyclist movements through the junction should be undertaken prior to any decision about placement of lane markings or symbols. Care should be taken not to direct cyclists into taking inappropriate riding positions through the junction – see guidance on primary and secondary positioning in section 3.1. Where there is insufficient space through a junction for a large vehicle to overtake a cyclist, for example, a marked lane should not be provided as cyclists should be discouraged from adopting a secondary riding position.

At side roads with restricted access or less than 5 metres wide, kerb-to-kerb, one rather than two diagram 1057 markings may be used. On Cycle Superhighways, the CS project symbols (diagram 1057 marking with route number on a coloured patch) may be used to mark continuity of a cycle facility through a priority junction.



TSRGD diagram 1057 symbols positioned so as to mark a cycle route through a junction

5.3.4 Segregated lanes and tracks at priority junctions

Some different considerations apply when lanes or tracks are physically separated from the carriageway. In all cases, speed reduction through use of methods such as raised tables, entry treatments and reduced corner radii is highly recommended. Visibility plays a significant role, so raising awareness among other road users of the presence of cyclists moving past a side road is important. For one-way cycle tracks, this visual priority may be achieved in one of three ways:

- Continuing the track through the junction without deviation where it is or could be raised above carriageway level

- Ending the separation ahead of the junction mouth, converting track to lane (or segregated lane to unsegregated lane) and returning the cyclist to carriageway level through the junction – also known as ‘bending in’ the cycle track
- ‘Bending out’ the cycle track away from the major road and into the mouth of the minor road, thereby giving any vehicle turning in space to wait and give way to a cyclist using the track

The first of these has the potential to offer the highest level of service for cyclists. The second can work well but is unlikely to contribute greatly to cyclists’ sense of safety. The third is the only one that gives formal priority to cyclists, but is less desirable in various other ways: it is less direct for the cyclist, adds to visual clutter, tends to require deviation of pedestrians from their desire lines, and requires more space than is usually available at a priority junction.

For any of these scenarios, coloured surfacing may be applied to reinforce the visual priority and highlight a location where conflicting movements will be taking place, but should not be relied upon alone to confer any sense of priority (see section 6.2.6).

Continuity without deviation

Continuing and raising a track through a junction without deviation has proved to be successful for stepped tracks. Although little UK practice exists, the principles are also applicable to kerbed segregation, subject to detailed design and undertaking a site-specific risk assessment. It requires a raised entry treatment and corner radii that are as tight as possible, forcing any turning movement in or out of the side road to take place at very low speed.

Consideration should be given to applying give-way markings for vehicles turning from the main carriageway into the side road, should space be available to do so, but the treatment relies more on visual priority than on any specific use of signing. This is likely to work well in combination with continuous footway and cycleway treatments (see section 3.5.3).

Reintegration ahead of junction

The second option relies on reintegrating cyclists with other traffic in the area around the priority junction, in order to maximise their visibility. This allows cyclists to adopt an appropriate riding position away from the nearside. The options set out above for treatment of cycle lanes at priority junctions may then be followed. Lanes should be marked as mandatory, with the TSRGD diagram 1049B marking, from the point where the segregation ends and then marked across the side road itself with diagram 1010 markings, as described above, with coloured surfacing optional.



Continuity of cycle tracks through priority junction: Old Shoreham Road, Brighton

Off-street trials conducted by TRL and recorded in the report PPR703: Trials of segregation set-back at side roads (2014) have generated some interim recommendations about set-back distances at priority junctions where kerbed segregation is provided for cyclists:

- Set-back should be 5 metres or less where 85th percentile motorised traffic speeds are lower than 30 miles per hour and the street geometry is tight
- Set-back should be 20 metres or more where 85th percentile speeds are greater than 30mph, allowing cyclists to reintegrate and take up a more visible position on the nearside

- The range 5 to 20 metres should be avoided, as this constrains cyclists but does not have a significant impact on the speed of turning motorised vehicles

These have not been corroborated in on-street trialling, and so caution is recommended in applying these recommendations. It is advisable to introduce speed reduction measures and implement other measures to highlight the intended priority of cycle traffic on the nearside.

'Bending out'

'Bending out' involves continuing the cycle track across the side road on a road hump, set back at least 5 metres from the carriageway. Both the TSRGD diagram 1003 (double-dash) and diagram 1023 (triangle) markings are marked on either side of the hump, requiring motor traffic to give way to crossing cycle traffic. This technique can also be used with less than 5 metres set-back if the side road is one-way, leading to the main road. Appropriate set-back, if any, should be determined by visibility considerations for vehicles exiting the side road, bearing in mind the need to give way to the cycle track.



Bent-out cycle tracks with priority at Waterden Road, Hackney. Note that elephants' footprints should not be used to mark this kind of crossing

The previous requirement for flat-topped road humps for bent-out cycle tracks on streets with speed limits of 30mph or less was removed in TSRGD (2016). Although the hump is no longer required, advice in the Traffic Signs Manual (paragraph 3.25) on other road markings should still be followed: for example, use of TSRGD diagram 1062 triangular markings and diagram 1023 'give way' markings.

For two-way tracks crossing two-way side roads, 'bending-out' by 5 metres is the recommended option. Where island separation is wide, this can be achieved with little or no deviation of the cycle track. Continuing a two-way track through a priority junction without deviation is possible, but brings with it various risks, related to the visibility of cyclists to turning motorised traffic.

It is not recommended unless traffic speeds and volumes are very low and other measures can be put in place to enhance visibility of cyclists – even then, it should be subject to a site-specific risk assessment. Closing side streets to motorised traffic is likely to be the only reliable way of dealing with these risks.

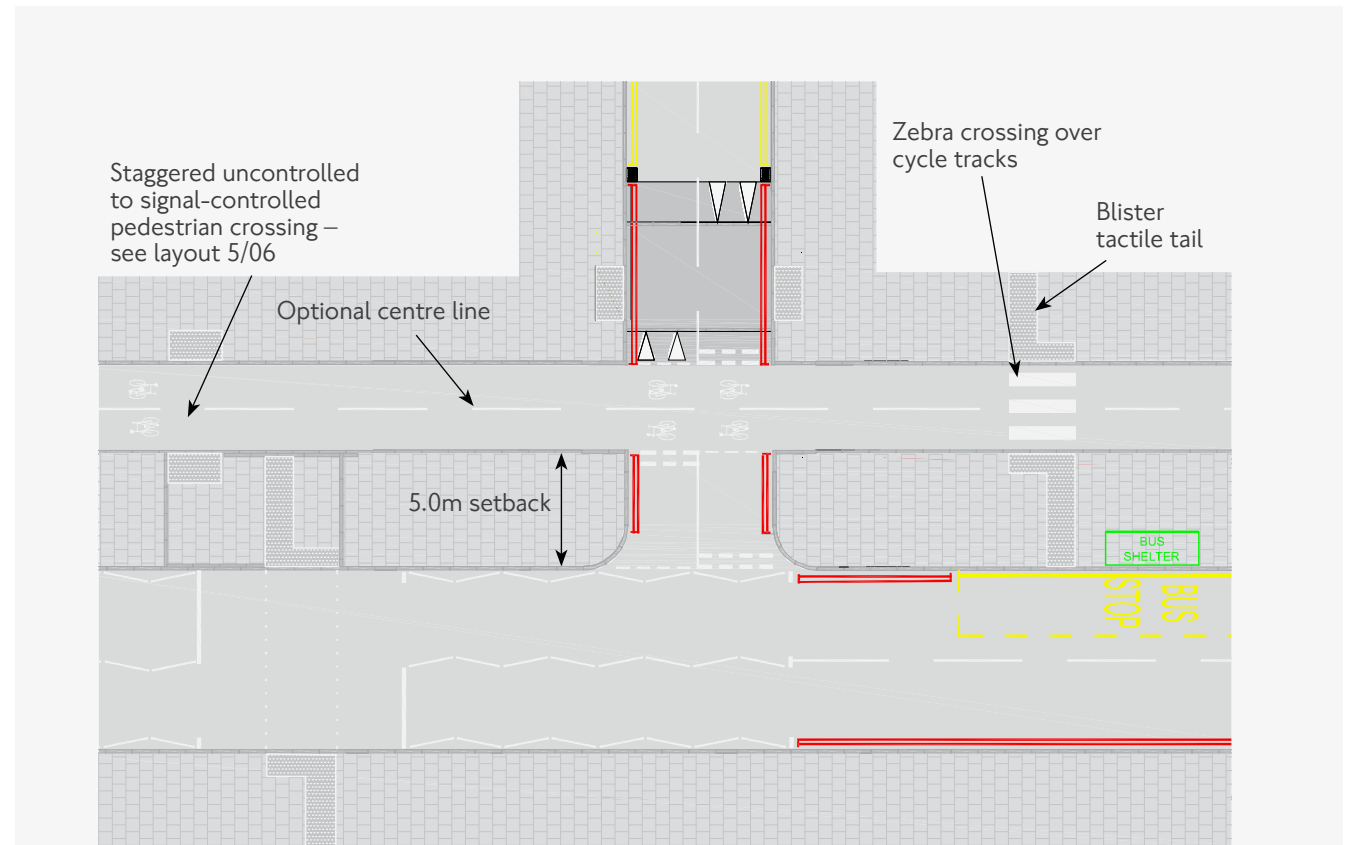

Indicative layout 5/07: Two-way cycle track with priority over side road, showing options for pedestrian crossing of cycle tracks

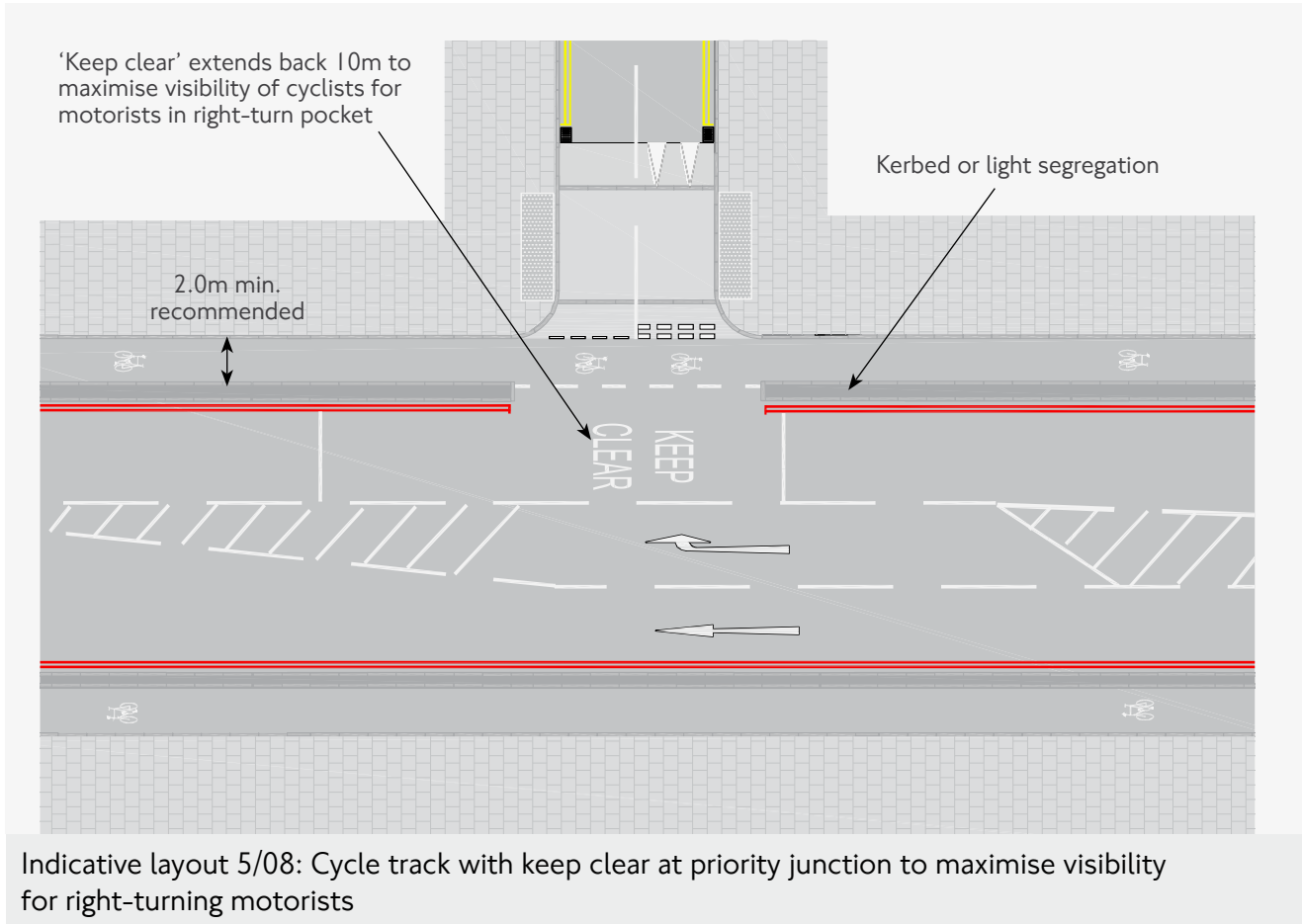

Two-way track continued across priority junction without deviation in a traffic calmed street – Cable Street, Tower Hamlets



Difficulties in highlighting to all road users that a two-way cycle track is crossing a side road – Tavistock Place, Camden

5.3.5 Cycling facilities across minor accesses

At access crossovers, priority may be given to cyclists without following the same options as for priority junctions. Where feasible, the access should be raised and narrowed. For larger accesses, a give way triangle (TSRGD diagram 1023) may be used to provide further warning to drivers leaving the access that they must give way to cyclists. At wide accesses, such as those at petrol filling stations, measures to slow down vehicles should also be considered, such as entry treatments and tightened geometry.

It is important to retain good visibility of the cyclists for drivers of vehicles intending to turn left across the cycle track. This means keeping the kerbside clear of street furniture and parked vehicles. It is also necessary for drivers leaving the access to have adequate visibility of approaching cyclists.



Track with suggested priority over minor side road entry

5.4 Signal-controlled junctions

5.4.1 Cycle-friendly interventions

Improvements to cycle safety and comfort, and to the directness and coherence of cycle routes may be achieved through remodelling, removing or introducing signal control at junctions, particularly where signal timings can be changed to reallocate time between road users and generate time saving benefits for cyclists. Intervention types covered in this section are summarised in figure 5.7.

5.4.2 Procedures for traffic signals

For any scheme involving traffic signals, authorities are required to comply with procedures set out in Design standards for signal schemes, SQA064 (2014) and any subsequent document updates. TfL Traffic Infrastructure prepares these design standards and is the Signals Authority for London, responsible for the design, installation, commissioning, maintenance and decommissioning of traffic signals and associated equipment. TfL Network Performance is responsible for the management and operation of London's traffic signals and their accompanying systems, technologies and equipment.

The Traffic Management Act 2004 places a Network Management Duty on all local traffic authorities (LTAs) in England. The Duty requires

Figure 5.7 Summary of options for cycle-friendly interventions at signal-controlled junctions

Signalisation to remove conflict	Complete separation at junctions involves signalling cyclists separately to remove all conflicting movements with other users.
Managing conflict with turning vehicles	This may be done by giving cyclists an advantage in time or space, or by seeking to move the point of crossing conflict away from the junction itself (managing the conflict).
Support for cycle right turn	As part of a segregated cycling system or a wider strategy on a route or a series of junctions to keep cyclists in a predictable position on the nearside, cyclists could be assisted with right turns by staying on the nearside and making the turn in two stages.
Cycle bypass of signals	In some instances, particularly through signalised T-junctions, cyclists making certain movements may be permitted a bypass of the signal control.
Using ASLs and feeder lanes	Advanced stop lines (ASLs) can help cyclists move away from a safer, more advantageous position at a signal-controlled junction at the start of a stage and so, selectively, can assist cycle movements through a junction.
Banning selected motorised vehicle movements	Generally in conjunction with other measures listed here, certain vehicle movements could be banned to improve cycle safety and directness. This should be done as part of a wider traffic management approach rather than on a case-by-case basis.
Convert to a priority junction	Signal removal can have some beneficial effects where the volume and mix of traffic and nature of conflicting movements does not necessarily justify the existence of a signal-controlled junction. See section 5.3.
Remove all priority and declutter	As part of an integrated, area-wide approach, designers may explore the potential benefits of removing signal control and priority altogether in order to promote more consensual road user behaviour generally. See section 3.4 on calming through street design.

the LTA to 'ensure the expeditious movement of traffic on its own road network, and facilitate the expeditious movement of traffic on the networks of others' (noting that this includes pedestrians and cyclists).

TfL Network Performance therefore uses journey time reliability as a practical measure to help clarify the legal responsibility. Modelling is the tool used to measure scheme impact on the network and effects on journey time reliability. The way this is applied across London is described in the Traffic modelling guidelines (version 3), issued in September 2010.

The primary purpose of traffic control by light signals is to separate conflicting traffic by the division of time, within the available road space, in a safe, efficient and equitable manner. (Traffic Advisory Leaflet 1/06, General principles of traffic control by light signals, 2006, Part 1) In the UK, traffic responsive detection technology is widely used to optimise the operation of traffic signals. This allows for sequence flexibility if no users are detected and for green signal optimisation during busy periods.

Pros and cons

Benefits arising from being able to control movements of road users at traffic signals need to be weighed up against the potential disadvantages to cyclists, and to pedestrians. Minimising delay is a primary objective in achieving a level of service that attracts new cyclists: few advantages are to be gained from

signals for cyclists that require them to wait a long time at signals. TfL's guidance states that at junctions with pedestrian crossing facilities, signal cycle times should only exceptionally be longer than 90 seconds.

Decluttering by minimising use of, or removing, traffic signals is positive for more attractive streets. Although it offers some adaptability through the ability to manage signal timings, junction remodelling with substantial changes to traffic signal infrastructure, may also place limits on the growth of cycling on a given route and necessitate further re-engineering in the near future.

Care should be taken to avoid introducing signal control where it is not justified. This can result in increased journey times for all users and is costly to install and maintain. Over-complicated signal staging and operation can lead to excessive waiting times for cyclists and an increase in frustration and non-compliance.

In seeking to improve cycle safety, comfort and directness at junctions, the timing of signals should generally be reviewed and optimised to minimise delay for cyclists, taking account of the needs of all traffic. When calculating inter-green timings allowance must be made for cycle movements to ensure cyclists can safely clear the junction. This is particularly important where cycle speeds are likely to be lower due to gradients.

5.4.3 Traffic signals for cyclists

The options covered here are generally trial measures that are being developed to enable separation of cyclists' movements through junctions. They all have the potential to become important parts of the toolkit for cycling infrastructure in the UK. Tried-and-tested designs and layouts will emerge in time but in order to develop agreed, standardised approaches, it is recommended that any proposals to use any of these measures are discussed with TfL or DfT from an early stage.

Red cycle aspect on standard traffic signal head

A standard traffic signal head can be used to control traffic consisting solely of pedal cycles. This signal includes green and amber cycle aspects and, following the publication of TSRGD (2016), can also incorporate a high-level red cycle aspect.

Off-street trials commissioned by TfL confirmed that a red cycle aspect on a standard traffic signal head is equally well understood and complied with by cyclists when compared with a full red aspect.



Standard signal heads with green cycle aspects

Low-level cycle signals

Following off- and on-street trials and changes to regulations (TSRGD 2016), low-level cycle signals may be used as alternatives to high-level, full-size signal heads. These have a minimum mounting height of 1200mm (to the underside of the signal head). They may be mounted on a pole used by high-level signal equipment or on their own 3 metre-high, wide-based pole.

TfL Traffic Infrastructure has developed guidance, SQA065 I Design for low-level cycle signals, that draws on TRL off-street trial research, on-street trial results, information about equipment and generic design considerations. The following

paragraphs give a summary of that guidance. For further technical detail, consult SQA065 I.

A low-level cycle signal may be used:

- As a primary signal, to control traffic exclusively made up of cyclists
- For early release, where the cycle signal gains right of way before its associated vehicle signal
- As a repeater, mounted at cyclists' eye-level under full-sized signal heads and showing the same information as the high-level signals

A primary low-level cycle signal may only be used in conjunction with a stop-line.

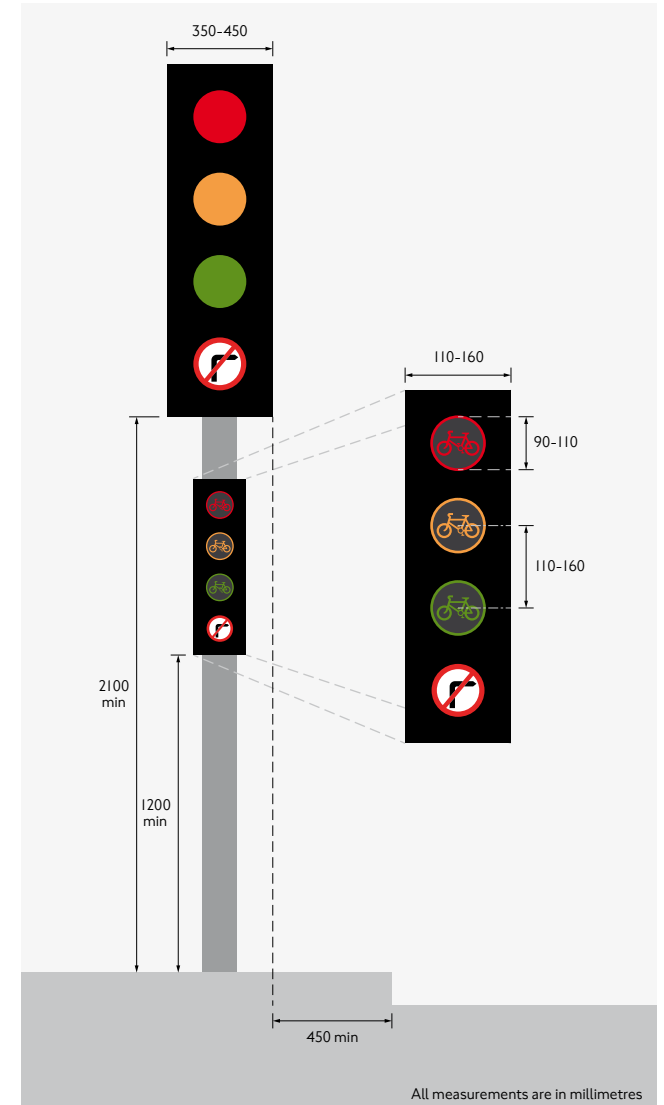

High-level and low-level signal head sizes and mounting heights, showing an optional box sign with banned right turn (low-level signal is acting as a repeater)

Box signs

One 100mm-diameter box sign may be mounted under the green cycle aspect of a low-level cycle signal, giving a four-in-line configuration. This may be required to indicate a prohibited or exclusive movement for cyclists: for example, TSRGD diagram 606 (proceed in the direction indicated by the arrow), 612 (no right turn) or 613 (no left turn). Where a low-level signal acts as a repeater, any box sign must replicate information displayed by the high-level regulatory box sign.

General layout considerations

A minimum horizontal clearance of 450mm should be provided between the edge of the carriageway and a low-level cycle signal. Less clearance is needed to a cycle track, indicatively a minimum of 250mm but to be determined on a site-specific basis (see section 4.2.3 on segregating island width). This means that any island that accommodates a low-level cycle signal alone effectively needs to be a minimum of 1.0 metre wide. Any island with a low-level signal mounted on a signal pole with a high-level signal should be at least 1.2 metres wide.

A primary low-level cycle signal should be 1.2 metres from and aligned at 45 degrees to the stop-line. A shallower angle can be considered for segregated lanes/tracks in order to avoid see-through problems and account for other site-specific conditions.

Where a secondary low-level cycle signal is installed, it should be aligned to a point in the middle of the carriageway or cycle lane/track and 2 metres upstream of the stop line. It should be within a 30 degree offset of the middle of the lane.



Detail of low-level cycle signal



High-level red cycle aspect with low-level cycle signal used as repeater

5.4.4 Cycle early release

Cycle early release signals allow cyclists to move away ahead of general traffic at signalised junctions. In most circumstances, early release should be applied to a layout with an advanced stop line (ASL), using a low-level cycle signal mounted under the associated primary traffic signal on a high-level signal pole.

On a single-lane approach, or where a formal two-stage right turn facility is provided, the low-level cycle signal should be mounted on the nearside signal pole only.

The amount of time given to cyclists by the early release depends on the junction dimensions and signal operation. It should be a minimum of 3 seconds, and above 5 seconds only in exceptional circumstances. At the end of green, the low-level cycle signal must lose right of way at the same time as the associated traffic signal.



Fourth aspect on standard signal head, giving cycle early release at Hills Road, Cambridge

5.4.5 Hold the left turn

TfL is planning to trial an arrangement that involves separately signalling cyclists and left-turning vehicles. This requires some segregation of lanes, a dedicated left-turning lane for general traffic, space for inclusion of islands for signal infrastructure, and provision for right-turning cyclists. It has potential for locations where there is a moderate volume of left-turning traffic and a large cycle flow ahead and/or left. Some separation at the stop line may also be needed of left-turning and ahead cyclists.



Visualisation showing proposal for 'hold the left turn'

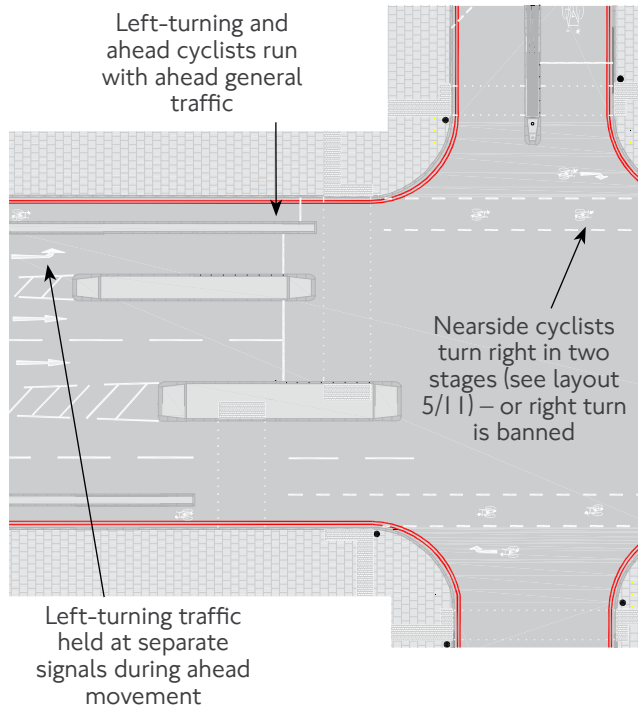

Indicative layout 5/09: 'Hold the left turn' concept

5.4.6 Cycle gate

A 'cycle gate' is an alternative method of giving cyclists some time and space to move away from a junction ahead of motorised vehicles. It could be applied where there are a large number of left-turning motorised vehicle movements, or 'scissor movement' conflicts, although it requires a substantial amount of space in terms of road width and depth of reservoir. It is essential that the signal operation gives cyclists enough time to clear potential points of conflict.

The cycle gate relies on there being two sets of signals and two stop lines for cyclists – the first acts as a 'gate' to allow cyclists into a 'cycle reservoir' ahead of general traffic to await a green light at the second stop line. The reservoir should not be marked in such a way as to make it appear like an ASL – for example, it should not have coloured surfacing or be marked with cycle symbols. Consideration for pedestrian waiting and crossing times also needs to be made, particularly in areas of high pedestrian flow.



Cycle gate at Bow: (top) segregated approach and first cycle stop line, and (bottom) advanced cycle stop line. Trial low-level cycle signals (used as repeaters) are mounted below the main signal heads

Layout principles for cycle gate are as follows:

- The cycle lane/track on the approach must be physically segregated, at least 1.5 metres wide, preferably 2 metres, to allow for overtaking. It may have coloured surfacing, up to the first cycle stop line
- The general traffic stop line should be positioned behind the advanced cycle stop line
- The segregating strip should widen to allow clearance for mounting the traffic signal head; for a signal head mounted in front of a traffic signal pole, the segregating strip should be at least 1.3 metres
- The distance from the first cycle stop line to the advanced stop line at the junction (the depth of the reservoir) should be at least 15 metres; this is to disassociate the two stop lines from each other and reduce the see-through issue between the two sets of traffic signals

Signal layouts with dedicated cycle phases may also be considered. Typically this is appropriate where one or more arms of the junction allow access for cyclists only, but it may also be applied where cyclists are physically segregated from other traffic.

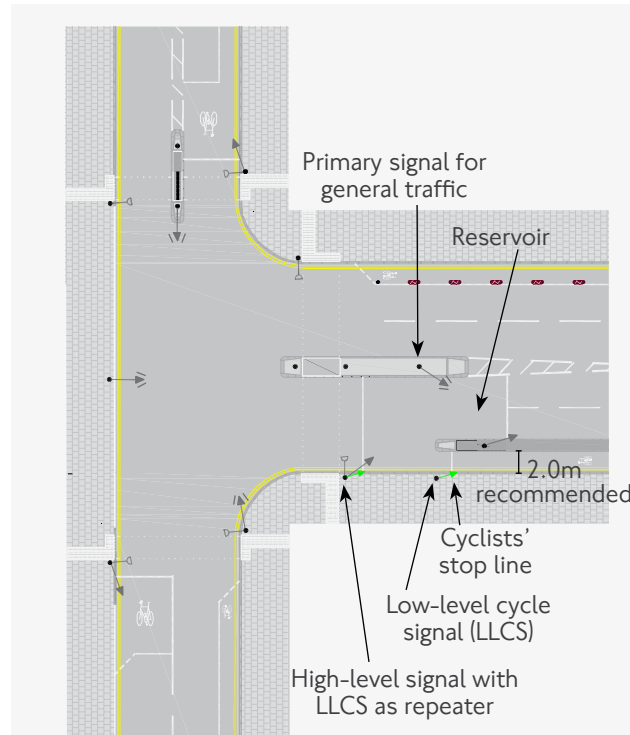

Indicative layout 5/10: Cycle gate, from SQA0651 (note that actual layout of each installation must be in accordance with the appropriate signal section site requirements)

5.4.7 Two-stage right turn

Traffic signals for cyclists have also been proposed for use with two-stage right turns – this is being explored in off-street trialling. Making a right turn in two stages while staying on the nearside of other traffic is an approach used in some other European countries (for left

turns) and is a potential solution to the problem of enabling cyclists to turn right when they are in segregated infrastructure on the nearside. The alternative would be to provide a gap in the segregation well ahead of the junction to allow right-turners to move out into general traffic and make the turn in the ‘conventional’ manner.



Two-stage left-turn marking at junction in Stockholm (top); and cyclists in different streams in Copenhagen (bottom) – left turners are heading to the waiting area to the right

It is already possible to make a right turn informally, although this not yet supported by specific road markings and signs. The cyclist crosses one arm of the junction in an ahead movement, pulls into the left and stops beyond the pedestrian crossing studs on the arm adjacent where they started. They then turn through 90 degrees to face their exit arm and wait for the traffic signals to allow them a second ahead movement. In this way, they can stay on the nearside and avoid having to move across lanes of traffic in order to turn right.

Lanes marked through junctions can assist cyclists making two-stage right turns informally by giving them lines to wait behind in between the two stages of their turn. In other countries, where two-stage right turns have more formal status, road markings and surface colour are often used to mark waiting areas or lines to assist making the second stage of the turn.

Formal two-stage right turn

TfL trialed a junction design off-street that enables a 'formal' two-stage right turn, with a marked waiting area and early release for cyclists. On-street use of this arrangement is being monitored, together with a two-stage left turn from a two-way cycle track on one side of a carriageway. SQA0651 Design for low-level cycle signals contains guidance based on the trial layout. Key points of advice are:

- Early release for cyclists in the ahead waiting area should be provided by a far-sided secondary signal

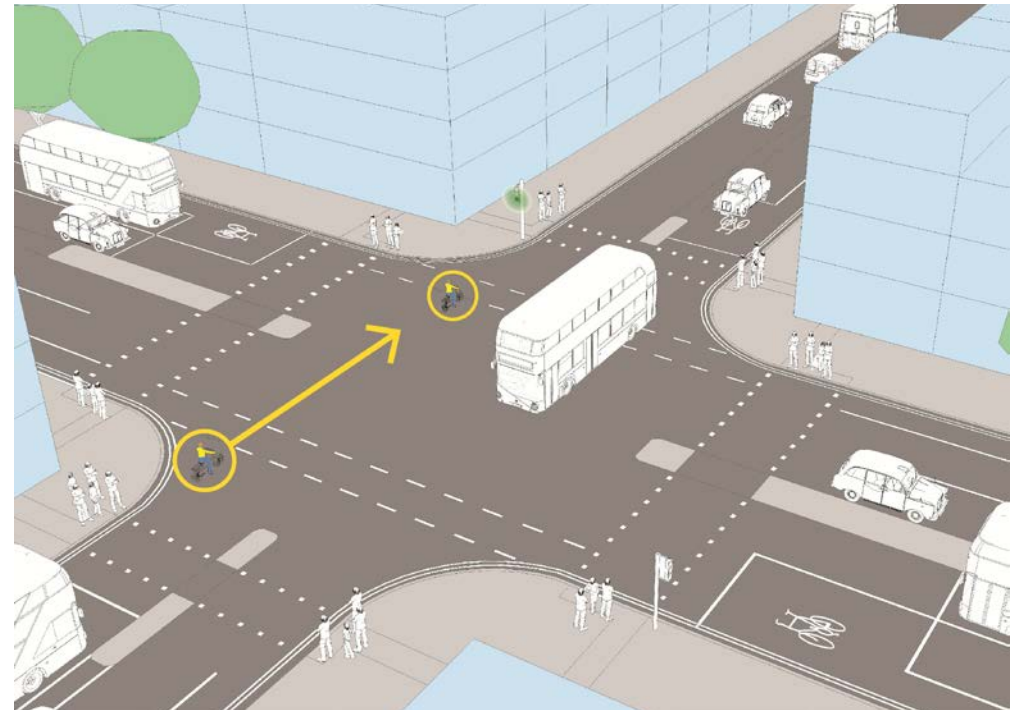
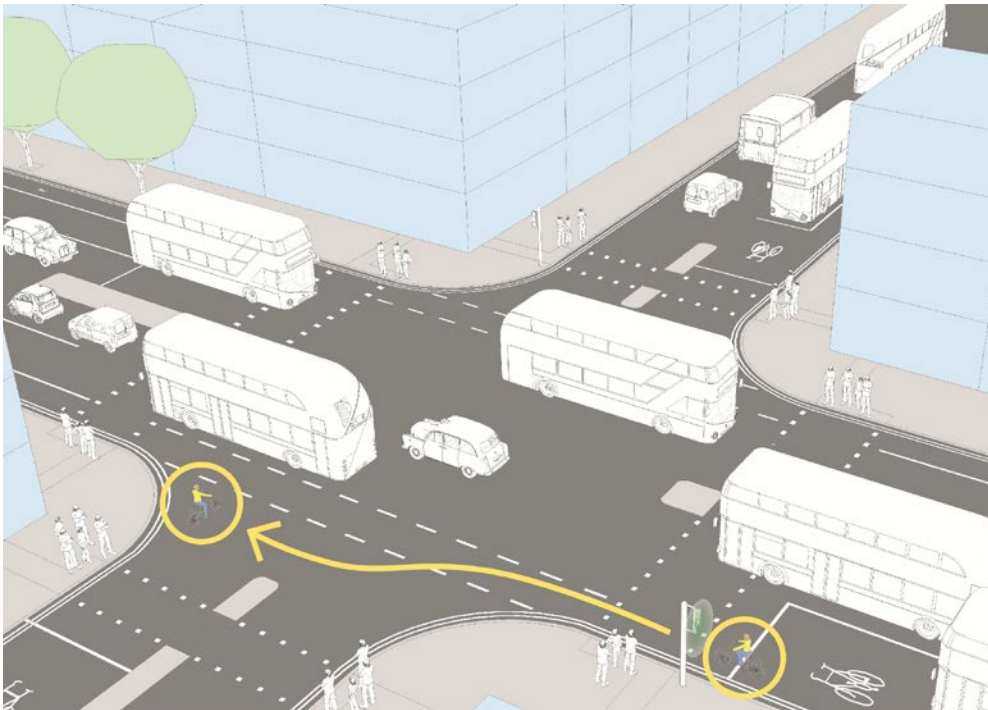

Informal two-stage right turn from the right-hand arm to top arm

- These cyclists must have a clear-sighted view of this signal, which should not therefore be a low-level signal, but should have a standard, high-level signal head, with a 200mm green cycle aspect as the fourth aspect (either to the left or in a four-in-line configuration)
- This secondary signal must turn to green at the same time as the low-level cycle signal for early release for cyclists waiting behind the stop line; the green cycle aspect must then terminate once the associated traffic phase gains right of way

Any proposal for a formal two-stage right turn should be discussed with TfL as early as possible.

Signing

It is proposed that a sign will be created to instruct cyclists how to undertake the turn ahead of the junction. This is likely to be based on the map-type sign to diagram 2601.2 of TSRGD.

The waiting area for the second stage of the turn should be marked with the cycle symbol to diagram 1057 and the cycle route direction arrow to diagram 1059. An important layout factor is the location of the waiting area in relation to the pedestrian crossing – there must be sufficient space to allow cyclists to move left of ahead traffic in the first stage of their manoeuvre, turn towards the waiting area and then position themselves correctly for their second stage. This should be calculated with the dimensions and turning circles of larger model of cycle in mind.



Trial of two-stage right turn, showing low-level cycle signals for early release

One other option for turning right in two steps is to allow the cyclists to leave the carriageway to the left and turn right by waiting and using a nearby crossing. This is usually done by introducing a dropped kerb ahead of a crossing that can be used by cyclists (stand-alone or as part of a signal-controlled junction) – a technique mainly used to provide a transition between on- and off-carriageway cycle facilities.

For turning right, this kind of arrangement, which is also illustrated in LTN2/08, page 64, is sometimes known as the G-turn or ‘jug handle’ layout.



Dropped kerb providing cycle access to shared use footway and shared crossing

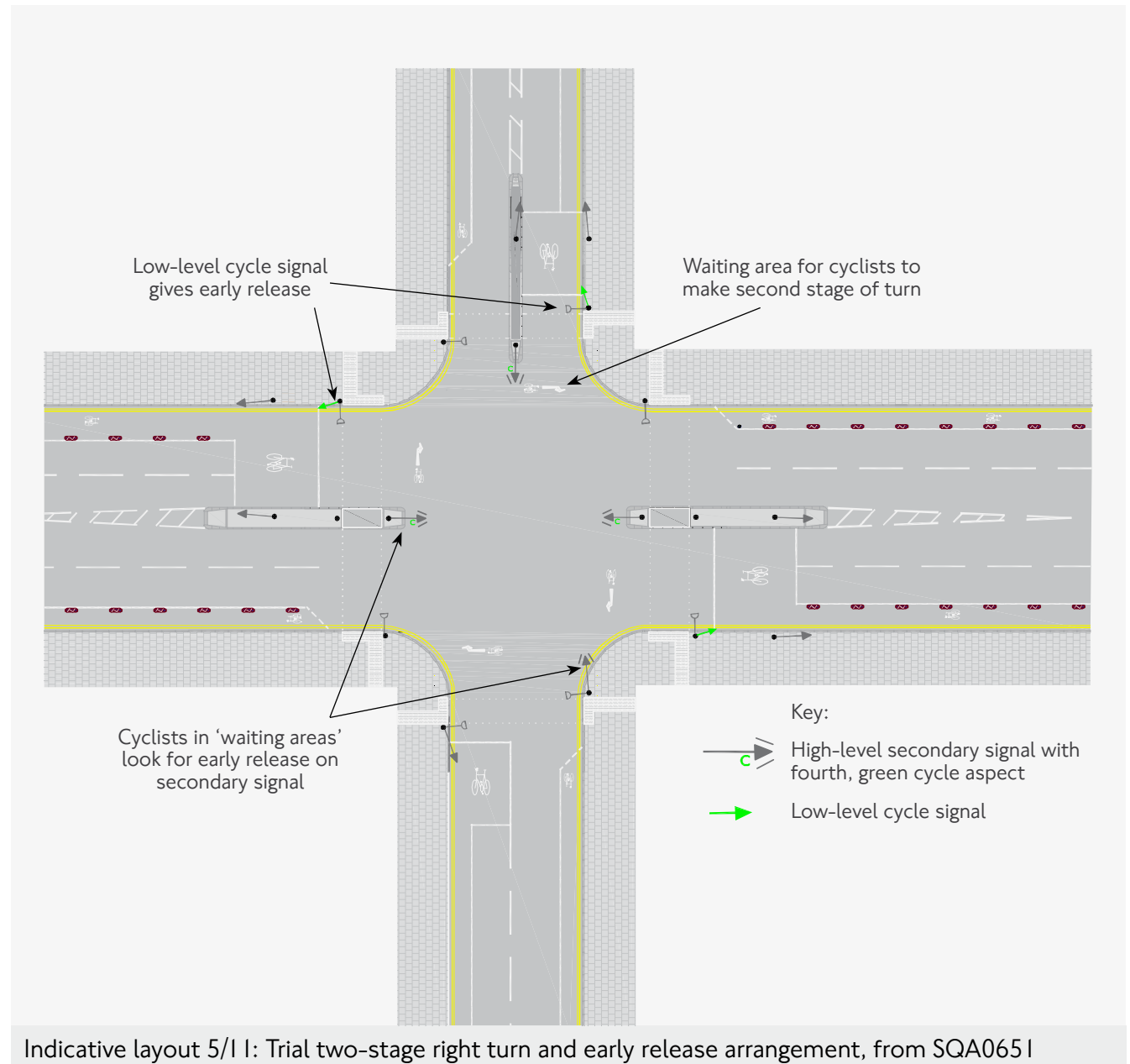

5.4.8 Other methods of managing conflicts

Where junctions are signal-controlled, separate signalling for cyclists and other traffic is the preferred way of dealing with left-turn conflicts by giving cyclists some protection in space and/or time.

Where the turning conflict cannot be removed, designers should seek to manage it and reduce the risk and severity of any collision. Calming traffic movements through the junction so that any interaction happens at lower speed is recommended – see guidance in chapter 3 generally. Tightening junction geometry and using junction tables can allow cyclists and slow-moving motorised vehicles to move through junctions with reduced risk of conflict. In low-volume and low-speed traffic conditions, ASLs and feeder lanes can be of benefit to cyclists, allowing them the advantage of an advanced position at the junction itself.

Banning turns for motorised traffic

Not allowing selected turns for motorised traffic can deliver a high cycling level of service. This can help in design of signal operation at the junction as well as removing a potential source of conflicting movements. Such a decision, however, should be taken in the light of a wider strategy for the road network around the junction in question. Banning a movement in one place could transfer that movement, and a risk to cycle safety, to another location. The design should support the ban and be self-enforcing, which generally means that physical measures are needed as well as signing.

Cycle bypass to signals

It may be possible to allow cyclists to bypass signals for general traffic, thereby enabling cyclists to clear the junction while other left-turning vehicles are held at a red signal. However, this is challenging to integrate with pedestrian crossing facilities and can generally only be done on a junction arm where there is no such crossing. Any such proposal should also avoid reducing pedestrian comfort levels through taking space from the footway to achieve a bypass.



Bypass to traffic signals for left-turning cyclists, Hills Road / Cherry Hinton Road, Cambridge

Dealing with left-turning general traffic lanes

Other scenarios, particularly those on street types with a higher movement function, will usually require different interventions. A particular risk is posed by left-turn general traffic lanes, multiple lanes for different movements at gyratories and free-flowing entry and exit slip lanes (usually for left-turning vehicles). Reduction in vehicle speeds, particularly on the turning movements, may help but it is also advisable to seek to reduce the distance where cyclists are vulnerable and move the point of potential conflict away from the junction itself.

The ideal solution is the removal of slip lanes by reconfiguring the junction, which can also release significant space for pedestrian and urban realm enhancements. If a slip lane cannot be removed, its length could be minimised by reducing the taper to 1 in 3 for 30mph roads and 1 in 5 for 40mph roads.

Where it is not practical to reduce the taper adequately, then continuing the ahead cycle lane past the left-turn slip lane will require left-turning vehicles to cross the cycle facility. The cycle lane should be projected ahead, without deviation, from the start of the left-turn flare. This can help add caution to driver behaviour and minimise last-minute lane-changing, particularly if the cycle lane is marked prominently – with surface colour, cycle symbols (to TSRGD diagram 1057) at 5-metre intervals and dashed lane markings (diagram 1010) to highlight the conflict, as appropriate.

However, it is not an ideal solution and cannot deliver anything more than a basic level of service for cyclists. Appropriate measures for managing the conflict at the point of crossover will depend on site-specific conditions such as available width, motor vehicle speeds and flows and mix of vehicles.



Long central lead-in to allow for left-turn flare, positioned to facilitate overtaking stopped buses



Use of dashed lane markings and surface colour to highlight a cycle lane to motorists seeking to enter a left-turn lane

Shared nearside lane

In some circumstances, it may be more appropriate to omit the cycle lane on the junction approach to encourage cyclists to take a primary position in the ahead lane. In that case, consideration should be given to marking and colouring the nearside lane in such a way as to suggest to motorised vehicles that they are merging into a cycle lane to turn left, rather than using a conventional left-turning general traffic lane.

On Cycle Superhighway pilot routes, use of this method showed no negative effect on conflicts and an increase in the separation distance between motor vehicles and cyclists, compared with a non-treated equivalent. Although offering only a basic level of service, this option may be useful where ahead movements from the nearside lane are restricted (eg to buses and/or cyclists only) and there are high proportions of left-turning motor vehicles. In this situation, signing to TSRGD diagram 877 (see Chapter 6) should be provided to permit specified road users to proceed ahead using the nearside lane at the junction.



Shared nearside lane

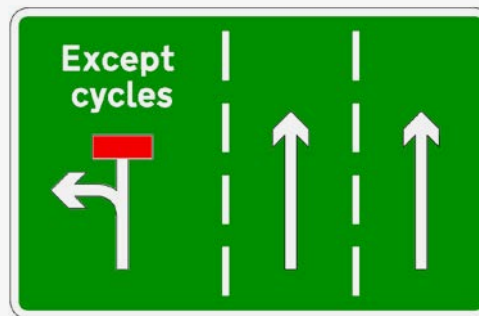

Variant of sign to diagram 877 of TSRGD
(site-specific authorisation required)

Cycle priority and protection at the conflict point

Where a slip road joins a main road, the cycle lane on the main road may, again, be continued through the conflict area and highlighted for other road users using surface colour and appropriate markings. Diagram 1003 give-way markings should also be used on the nearside of the cycle lane, to require vehicles joining the main road to give way to cyclists and other vehicles on that road.



Kerbed island up to an ASL helps to maintain space for cyclists as vehicles turn in a gyratory system. Drivers have to make a clear and early lane change ahead of the segregation in order to turn right

Light or island segregation may be considered as a way of protecting cyclists. This can protect the junction approach and focus the point of crossover, encouraging motorists to keep their distance from the cycle lane.

The principle of using island separation could be applied to bespoke junction redesign in order to give protection to cyclists. Separation of this kind is likely to form the basis for future experimental layouts, in conjunction with innovative use of traffic signals. Any proposal using these methods should be regarded as a trial.

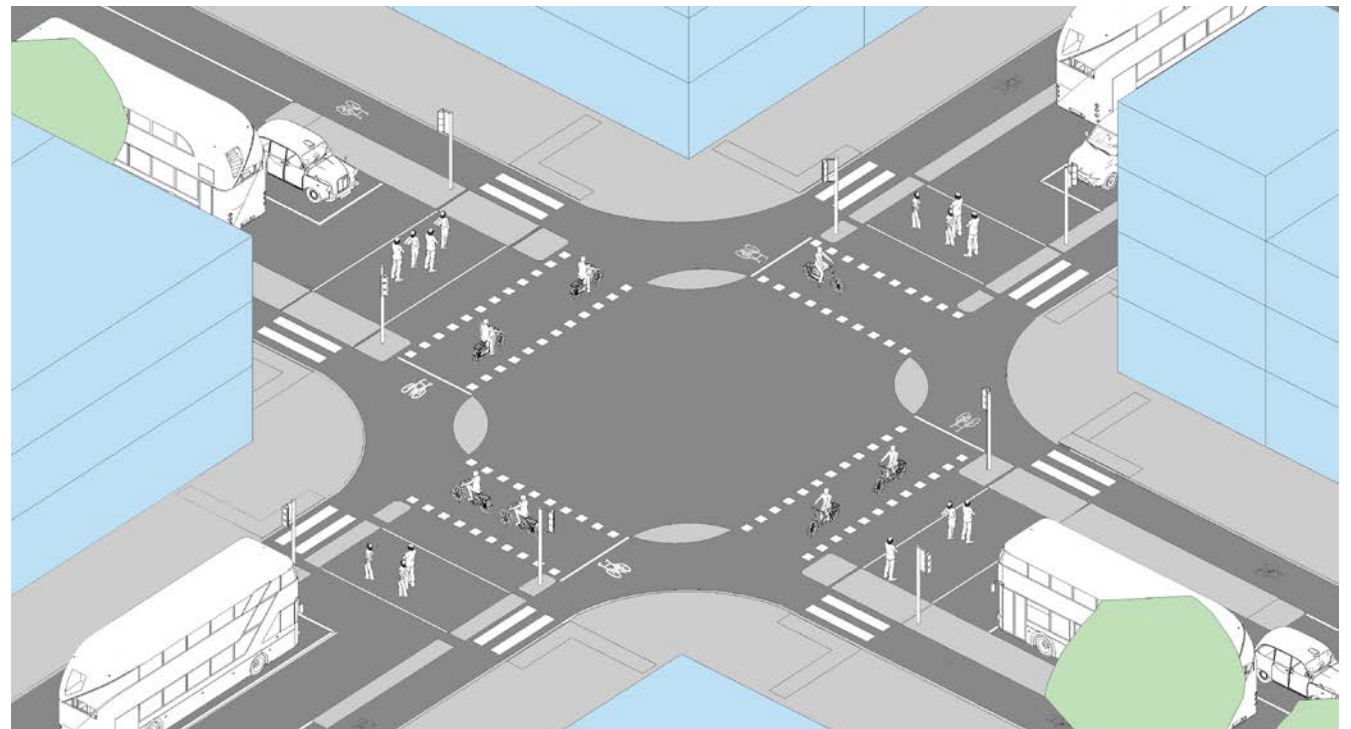

Concept sketch for a junction redesign involving island protection

Highlighting the conflict point

Through the junction itself, marking and potentially colouring the cycle lane can highlight to other road users the likely ahead movement of cyclists and encourage a more cautious approach to turning across such a facility.

The markings should support good road positioning, but it is not necessary for cyclists to stay within the area marked – the principal function of these markings is to influence driver behaviour on turning, not the behaviour of cyclists. Lane markings should be to TSRGD diagram 1010 markings (or variant as necessary), used together with cycle symbols to diagram 1057.

This method is best used when cyclists approach from a nearside lane or track and should remain on the nearside for ahead as well as left-turning movements. This may well be the case for segregated infrastructure and where a two-stage right turn arrangement is in place. Where there is no nearside lane or track before or after the junction, or where cyclists should adopt a more central riding position through the junction, this technique should not generally be used.



Lane markings and surface colour continued through junctions on Cycle Superhighways



Use of coloured surfacing for cycling through junctions in Copenhagen

5.4.9 Advanced Stop Lines

Where provision for cyclists is on-carriageway and unsegregated, signalised junctions should incorporate an advanced stop line (ASL). Where they are properly enforced, ASLs and associated facilities can be used to give cyclists a basic level of service and some degree of priority, and they can help to raise driver awareness of cyclists. The TRL report, PPR240, Behaviour at advanced cycle stop lines (2005) covers observed benefits, describing how, with an ASL, more cyclists are able to access a position at the front of queuing traffic and how encroachment into the pedestrian crossing area by cyclists is reduced.

ASLs should not, however, be relied upon alone as a measure to cater adequately for cyclists at signalised junctions as the benefits they offer are conditional upon the stage of signal cycle when the cyclist arrives at the junction, and on how they are accessed under different traffic conditions. They may also be of limited use to people riding non-standard cycles, particularly wider models, if inadequate space is available to access the stop line. All ASLs and their methods of access need careful consideration at the design stage, taking into account junction layout, traffic flows and movements and signal operation.



Important considerations include ASL capacity and the practicality and comfort of making right-turn manoeuvres using the ASL

Where they are well designed and can be accessed by all users of all types of cycle, ASLs can help cyclists to: position themselves in drivers' line of sight, avoid conflict with left-turning vehicles (when arriving on a red light), wait away from direct exhaust fumes, and enjoy a head start over motorised traffic.

Design requirements

The ASL waiting area may be between 4 and 7.5 metres deep, as established in TSRGD (2016). Under most circumstances, 5 metres should be used, with up to 7.5-metre deep ASLs considered for locations with high cycle flows.

A set-back of 1.7 to 3 metres is required between the advanced stop line and pedestrian crossing studs. 1.7 metres is recommended for cycle routes as it can lead to cyclists waiting in safer and more visible locations ahead of stationary traffic and can allow for tighter geometry at the junction. Swept path analysis must inform the choice: a greater set-back distance may be required to avoid encroachment from the swept path of large vehicles where there are no splitter islands. Alternatively, a part-width ASL may be appropriate.

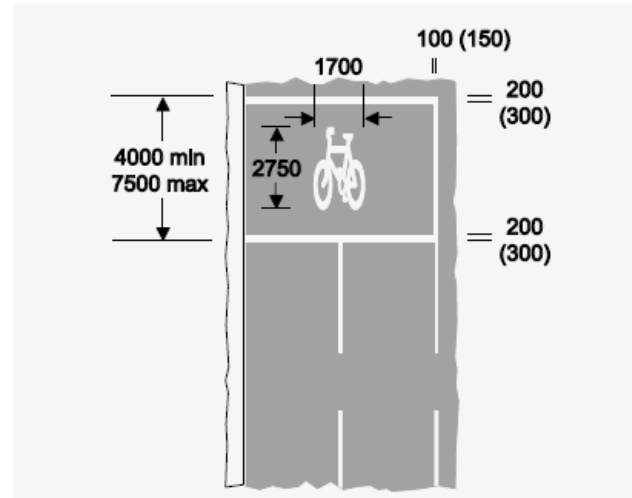

TSRGD (2016) diagram 1001.2B – separate stop line for pedal cycles, without lead-in or gate entry

The solid longitudinal lines that bound the ASL box on either side must be provided, unless that part of the carriageway is delineated by a raised kerb. In practice, this is usually the case for the nearside and relates to the offside where there is an island. Colouring the ASL box is not required unless there is an identified need to highlight the location as a point of particular conflict.



Narrow lead-in lane on street with no centre line, so vehicles tend not to queue over the lead-in lane



ASLs with lead-in lanes are also used in other countries – as in this example from Utrecht

Nearside lead-in lanes

A mandatory lead-in lane to an ASL is recommended, although advisory lead-ins and gate entry are also possible. A balance needs to be struck between the added protection and subjective safety that a mandatory lane is able to offer over an advisory lane, and the greater flexibility in use of space that an advisory lane gives.

In some circumstances, an advisory lead-in lane wider than 1.5 metres next to a narrow (3 metres or less) general traffic lane may be preferable to a narrow (1.2 metres) mandatory lead-in next to a wider general traffic lane, if it encourages drivers to give more space on the nearside.

ASL lead-in lanes and gates are optional because TSRGD (2016) allows for cyclists to cross the first stop line at any point.

Where a lead-in is provided, it should be at least 1.5 metres wide. A width of 1.2 metres may be preferable to no lead-in, depending on the likely level of encroachment by motorised vehicles, but it will not permit access entirely within the lane by all types of cycle. Lead-in lanes may benefit from colour, where there is a need for conflicting movements to be highlighted, and TSRGD diagram 1057 cycle symbols to discourage encroachment.

Ideally, the lead-in should be as long as the maximum general traffic queue length during peak periods. The benefits of a long lead-in need to be balanced against the risks of encouraging

cyclists to pass waiting vehicles on the nearside. Where buses and HGVs are present, a short lead-in may be more appropriate.

Protection for the lead-in lane may be considered. Road user behaviour under different traffic conditions needs to be taken into account, with the aim of encouraging drivers to give as much space on the nearside as possible. The need for consistency of provision should also be taken into account – if mandatory lead-ins are provided on a given road, they should ideally appear at every signalised junction.

The general traffic lane adjacent to a lead-in should be a minimum of 3 metres wide. If an advisory lead-in lane is 2 metres or more wide, then the adjacent general traffic lane may be reduced down to a minimum of 2.5 metres wide, although this is likely to mean some encroachment on the lead-in at busier times. Where there are narrow traffic lanes and only a narrow lead-in is possible, it is likely to be preferable to omit the lead-in altogether and encourage cyclists to take a primary position in the nearside lane through use of centrally placed cycle symbols.

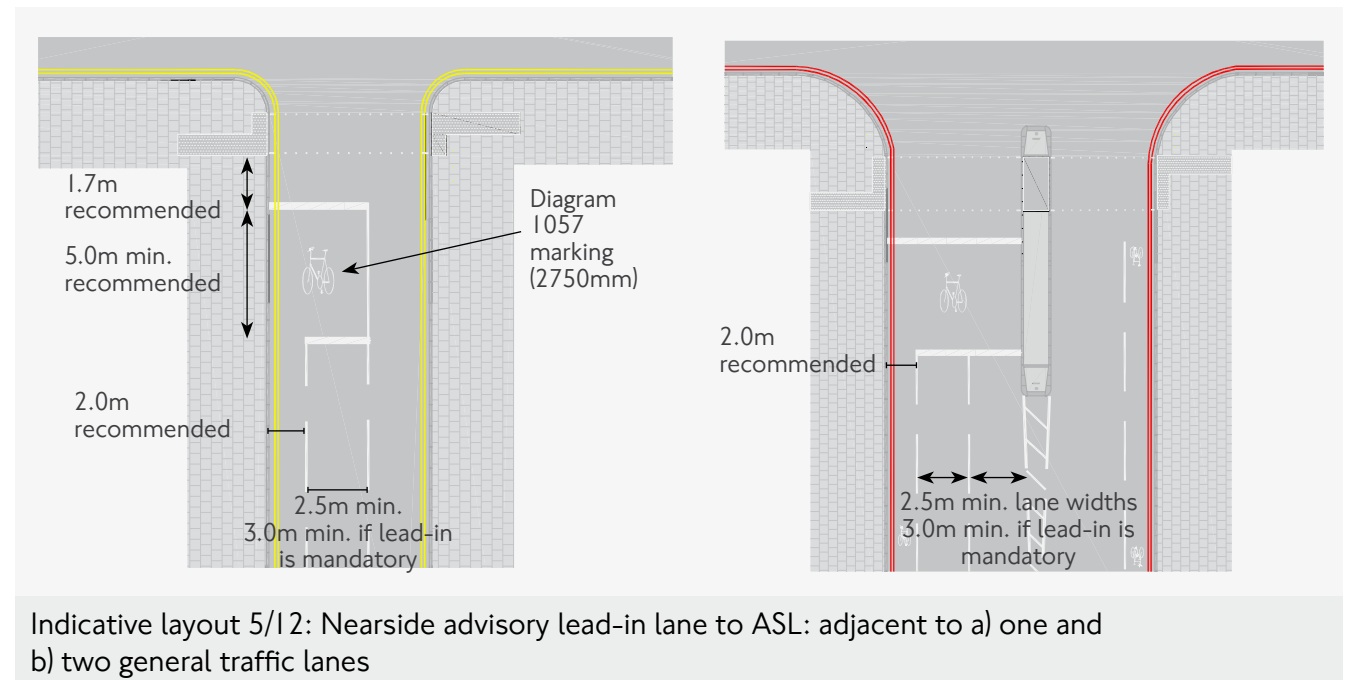

Gate entry

Provision of 1 metre-wide 'gate' entry to an ASL, using the TSRGD diagram 1001.2A marking, is an option that allows legal entry for cyclists to the reservoir where a lead-in lane cannot reasonably be provided. In all cases, a lead-in lane is preferable; gates represent a lower level of service. Nearside gate entry was included in amendments to TSRGD in 2011. However, since TSRGD (2016) allows for an ASL with a solid first stop line (diagram 1001.2B), there will rarely be a need for designers to include gate entry, particularly where the gate entry would have been on the offside.

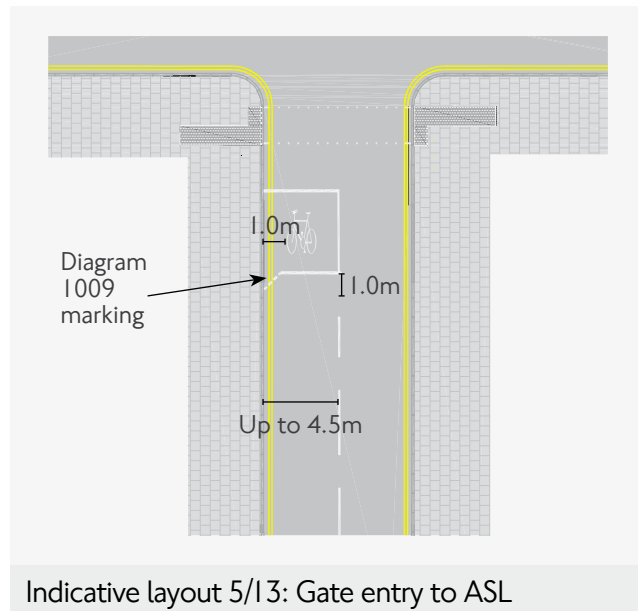

Central or offside lead-in lane

Another option to reduce the risk from left-turning motor vehicles is a centrally located or offside ASL lead-in lane. Central lead-in lanes should be at least 2 metres in width and should be used in conjunction with speed calming measures that reduce the level of risk arising from crossing movements. As is the case with all ASL lead-in lanes, the option of omitting the lane altogether is very likely to be preferable to a facility with sub-standard widths and may be considered in cases where the width can be provided, depending on traffic conditions. Refer generally to the advice above on cycle lanes marked on the nearside of left-turning lanes, including the use of segregation to protect the junction approach.

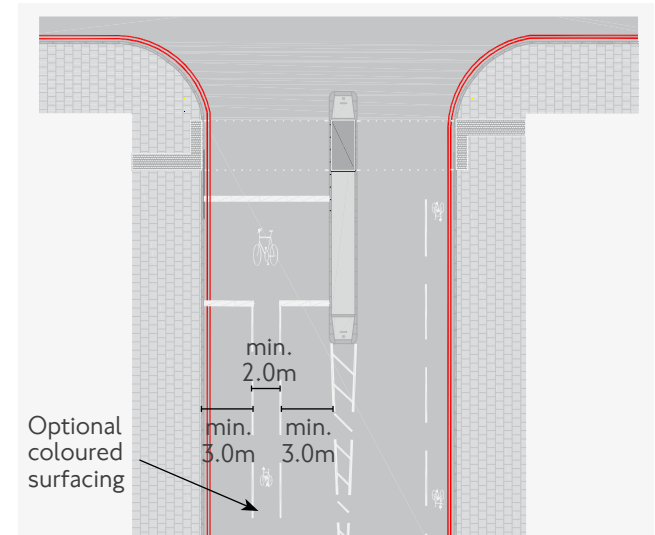

Part-width ASLs

In some situations, part-width ASL boxes may be appropriate. These are not prescribed in TSRGD (2016), so site-specific authorisation is required. They do not cover the full width of all the approach lanes and tend to be better observed by motorists than full-width ASLs. They may be applicable where:

- Right turns are not permitted (for cyclists or all vehicles)
- There are multiple right-turning lanes
- Tracking of vehicle movements into the arm of the junction shows that they would encroach on the ASL reservoir if it were full-width
- A nearside lane is controlled with a left-turn filter signal



Part-width ASL used where right-turning vehicles would over-run a full-width ASL – Ruckholt Road, Waltham Forest

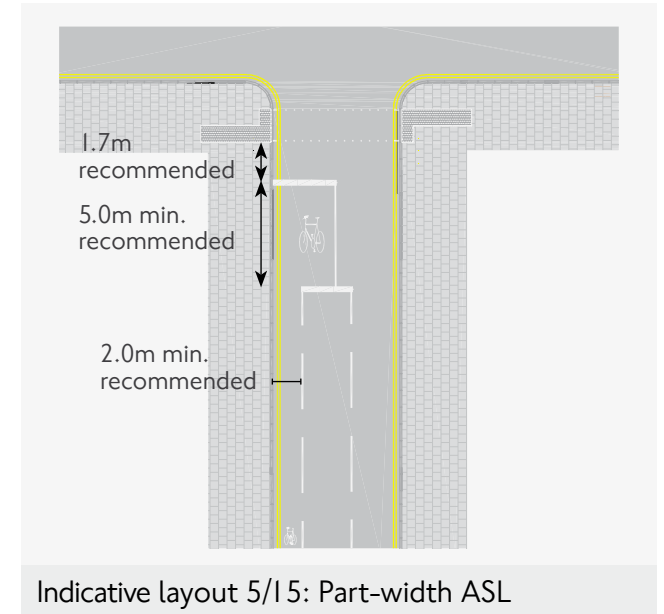

Indicative layout 5/I 5: Part-width ASL

Split ASLs

Split ASLs are possible on a single junction arm where movements are separately signalled and where lanes are physically separated by an island.



ASL across two lanes only from one-way street (offside lane is a bus lane) – Gower Street, Camden



Split ASLs with island, Curtain Road, Hackney

Where there are multiple traffic lanes, there may be a case for marking recommended positioning for different cyclist movements through use of a split ASL with a dividing line and direction arrows for cyclists.

A good example would be where there is a left filter movement for general traffic that precedes the ahead movement, and where it would be appropriate to indicate specific suitable places to wait for cyclists undertaking different movements. Site-specific authorisation is required for this technique.

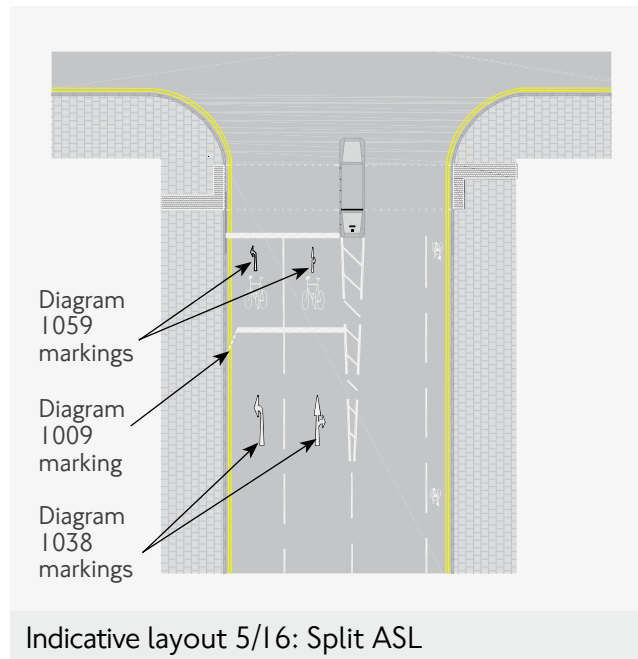

Following the publication of TSRGD (2016), ASLs can be used at stand-alone signalised crossings as well as signalised junctions. Since zig-zag markings are required, it is not possible to have a cycle lead-in lane or gate entry in this instance – a solid (diagram 1001.2B) first stop line should be used. The zig-zags may, however, be offset by up to 2 metres from the kerb, as described above.

Blind-spot safety mirrors

At junctions with ASLs, blind-spot safety mirrors mounted on signal poles can help give motorists a better view of cyclists in a lead-in lane on their nearside and in the ASL box. Their use is prescribed in TSRGD (2016), having previously been subject to an area-wide authorisation by DfT to local authorities in England in February 2012.

There is currently little evidence of the safety benefits of blind-spot safety mirrors and trials of their effectiveness have been inconclusive.

Any decision to include blind-spot safety mirrors should be taken by the authority responsible for signing (rather than traffic signal equipment). However, since they are mounted on signal poles, their installation will need to be considered and assessed by TfL Asset Management Directorate in a similar way to any other signal equipment. A risk assessment should also be made, with mirrors being most appropriate at junctions with both ahead and left-turn movements and where there are high cycle and HGV flows.

To achieve the optimum position, and reduce the risk of tampering and vandalism, mirrors will usually be mounted on the nearside primary signal pole, with 2.4 to 2.5 metres clearance to the footway. Ongoing maintenance costs must be considered by the scheme sponsor.



Blind-spot safety mirror showing view of nearside lead-in lane

5.5 Roundabouts and gyratories

5.5.1 Cyclists' use of roundabouts

Roundabouts and gyratories are rarely comfortable facilities for cyclists to use. It is essential to understand cyclists' desire lines and manoeuvres in order to provide for their safety.

At many UK roundabouts, the geometry creates difficulties for cyclists by not sufficiently reducing motor vehicle speeds. On the other hand, the ability to keep moving through the junction with no loss of momentum makes some types of roundabout, when well designed, potentially more appealing to cyclists under some circumstances than signal-controlled junctions.

Most collisions involving cyclists arise from vehicles entering the roundabout and colliding with cyclists who are on the circulatory carriageway. For all types, general approaches that can help reduce risks to cyclists include:

- Reducing entry, circulatory and exit speeds, eg by tightening entry and exit geometry and reducing excessive visibility
- Reducing motorised traffic volumes
- Reallocating unused carriageway space, such as reducing number of approach lanes to one
- Minimising the need for drivers to change lane on the roundabout

- Raising driver awareness of cyclists
- Giving cyclists clear, unobstructed passage up to, through, and on the exit from the roundabout
- Encouraging cyclists to take a visible position away from the nearside when circulating
- Managing traffic and conflicting manoeuvres through the use of signals
- Providing an alternative route or by-pass for cyclists that does not result in additional delay

As a rule, **the larger the roundabout, the greater the problems for cyclists.** On cycle routes, large roundabouts and gyratories should be considered for conversion to simpler signalised junctions or more cycle-friendly roundabout types. Where roundabouts remain, speed reduction is highly recommended.

5.5.2 Roundabout types

Roundabouts vary greatly in the UK by type, location and usage. The size of a roundabout, and the volumes and speeds of motorised traffic it accommodates, has an impact on the subjective safety of vulnerable road users, particularly cyclists. Pedestrians also suffer where they are required to undertake circuitous and often hazardous routes to negotiate a large

roundabout. Types are defined in DMRB TD16/07 (2007), as follows, with a comparison provided in figure 5.8.

Normal – a roundabout with a kerbed central island at least 4 metres in diameter, usually with flared entries and exits. Small versions have a single-lane circulatory carriageway. Larger versions can have multiple lanes, or enough width on the circulatory carriageway and on the arms to accommodate two or three vehicles alongside one another.

Compact – a roundabout having a central island, with single-lane entries and exits, and with a circulatory carriageway that does not allow two cars to pass one another.

Mini – indicated by a domed or flush circular solid white road marking to diagram 1003.4 of TSRGD, between 1 and 4 metres in diameter, instead of a central island.

Signalised – a roundabout having traffic signals on one or more of the approaches and at the corresponding point on the circulatory carriageway itself. Design guidance for signalised roundabouts is provided in DMRB TD50/04 (2004).

Double – a junction comprising two roundabouts (normal, compact or mini) connected by a short link and designed as a single system rather than two separate roundabouts.

Figure 5.8 Comparison of roundabout types

Design feature	Roundabout type			
	Normal	Continental (TAL 9/97)	Compact (TD16/07)	Mini
Approach arms	Ideally perpendicular but can be skewed	Perpendicular	Perpendicular	Preferably perpendicular but can be skewed
Entry width	Add one lane to entries	One lane, usually 4m	One lane, usually 4m	Variable
Entry radius	20m, 6m minimum	Not specified but about 10m	Not specified but about 10m	Not specified
Entry angle	Preferably 20° to 60°	Approx 30° to 45°	Preferably 20° to 60°	Deflection desirable
Entry path curvature	Not to exceed 100m	Not to exceed 100m	Not to exceed 70m	Not specified
Exit arms	Easy exits	Tight perpendicular exits	Tight perpendicular exits	Not specified
Exit radius	40m desirable, 20m minimum	Approx 10m	Approx 10m	Not specified/max 5m
Exit width	Add extra lane	Single lane	Single lane 4-5m	Not specified
External diameter	28-100m	25-35m	28-36m	Dependent on movements
Island diameter	Min 4m	16-25m	4-18m (including overrun area)	1-4m
Circulatory carriageway	1-1.2 times entry width	Single lane 5-7m	Single lane < 6m	5-7m

5.5.3 Normal roundabouts

Normal roundabouts with single approach lanes and low flows will normally be satisfactory for cyclists as long as the geometry is 'tight'. Large conventional roundabouts, however, pose greater risks and are likely to be deemed too hazardous to use by a significant number of cyclists.

Signalised roundabouts

One intervention that has been shown to have safety benefits is to signalise the roundabout. A study of before and after collision data of 28 roundabouts that had signals installed found a statistically significant decrease in the number of collisions involving cyclists (TRL, PPR 436, Literature review of road safety at traffic signals and signalised crossings, 2009).

This report also cites a TfL study from 2003 of 20 junctions, finding significant safety benefits for cyclists from signalisation for the at-grade types (F. Martin, An analysis of accidents at roundabouts 'before' and 'after' signal implementation, London Accident Analysis Unit, 2003). Despite this, large roundabouts are likely to remain a deterrent to non-cyclists or less confident cyclists even after signalising them.

As described in DMRB TD50/04, signalised roundabouts vary significantly: some or all of the arms may be signalised; the signals may be on the external approaches only, or on both external approaches and on the circulatory carriageway;

and the signals may operate full-time or part-time. Taken together with differences in numbers of arms and lanes, there are therefore many permutations governing how they operate. Whether they provide good facilities for cyclists tends to depend on the detail of how potential conflicts have been managed.

Minimising risks to cyclists

The greatest degree of separation that could be implemented would be to remove cyclists from the circulatory lane of the roundabout altogether. Subject to design considerations set out in section 7.5, grade separation can be effectively achieved through use of subways and bridges. Alternatively, cyclists on each entry arm may be led off-carriageway to cross other arms on parallel pedestrian/cycle or toucan crossings. For large roundabouts, pedestrian and cycle access through the centre of the roundabout may be a good option to explore.

In this instance, the potential for delay to cyclists and for pedestrian-cyclist conflict from shared infrastructure needs to be balanced with the safety benefits of removing cyclists from the carriageway. The needs of vulnerable users, both pedestrians and cyclists, must be taken into account. This includes providing adequate widths and dropped kerbs to ensure accessibility for users of all types of cycle.



Off-carriageway cycling at roundabout in Berlin – motorists give way to crossing cyclists

Other ways to reduce the risks to cyclists include:

- Minimise the number and width of entry, exit and circulatory lanes; more than one entry lane greatly increases the number of potential conflicts involving cyclists at the roundabout see figure 5.8 for guidance on lane widths
- Reduce circulatory speeds by introducing over-run strips around the central island of the roundabout, thereby reducing the width of the circulating carriageway
- Minimise entry and exit flares (between 20 degrees and 60 degrees) generally, aim to provide arms that are perpendicular, rather than tangential to the roundabout

- Provide entry deflection to the left on entering the roundabout
- Provide islands to segregate cyclists at entry/exit and greater deflection for motorised vehicles
- Remove unused carriageway space and increase size of deflector islands while ensuring pinch-points for cyclists are not created
- Provide spiral lane markings for general traffic to improve lane discipline
- Put the whole junction on a table, which can help reduce speed on entry and exit, but is unlikely to make a difference to speed on the circulatory carriageway

Note that many of these measures suggest conversion to another roundabout type – a compact or continental form. For a cycle route, this is preferred to modifying a ‘conventional’ roundabout.

5.5.4 Mini-roundabouts

Mini-roundabouts are not generally recommended for inclusion on cycle routes. The main problems they raise are failure of vehicles to observe give way due to the geometry and failure to reduce speed through the junction. Where they exist, they should be considered for replacement where they have more than one entry lane and/or where there is an angle approaching 180 degrees between the entry and exit arms (and therefore little horizontal deflection).

Interventions that could improve existing mini-roundabouts for cycling include:

- Minimising entry and circulatory widths and speeds
- Altering geometry to create greater deflection angles
- Making it impossible for vehicles to overtake within the roundabout circulatory area
- Reducing single lane carriageway to a maximum width of 5 metres
- Increasing the central dome marking (to TSRGD diagram 1003.4) to 4 metres' diameter to slow general traffic
- Incorporating a speed table to reduce speeds on entry and exit
- Incorporating additional deflector islands for motor traffic (and considering omission of 'keep left' bollards from those islands wherever possible, as these can impair the visibility of turning motor vehicles and their indicator lights – such a proposal should be subject to a risk assessment)

5.5.5 Compact and continental roundabouts

These two types of roundabout are described, respectively, in DMRB TD16/07 (2007) and in TAL 9/97, Cyclists at roundabouts: continental design geometry (1997). They can be useful in

addressing cycle and pedestrian safety issues because they reduce motor vehicle speeds significantly and they prevent weaving and overtaking on the circulatory carriageway, making it easier for cyclists to adopt the primary riding position around the roundabout.



Compact roundabout in UK with overrun strip



'Continental' roundabout in Lund, Sweden

As outlined in TAL 9/97, 'continental' roundabouts, which may be suitable for flows of between 5,000 and 20,000 vehicles per day, are likely to have a positive impact on cyclists' safety and comfort because:

- Their tighter geometries encourage all vehicles to take the junction more slowly
- They provide only one lane on entry and exit on every arm
- The central island is larger relative to the overall size of the junction when compared to a 'conventional' roundabout, meaning that the entry path curvature of circulating vehicles is increased (they are deviated more and therefore cannot take the roundabout at higher speeds)
- They are recommended for use in lower speed, lower traffic volume contexts (towards the lower end of the 5,000 to 20,000 vehicles per day range)

They are also advantageous for pedestrians because the tighter geometry allows for pedestrian crossings on desire lines much closer to the entry to the roundabout than would be the case for conventional roundabouts.

International best practice shows that roundabouts of this type may also be appropriate in situations where cycle flows are heavy (cyclists comprising a very high proportion of all traffic). This has been seen to be reinforced in some instances by prominent use of the cycle symbol on the circulatory carriageway.



Roundabout in Nantes, France

Compact roundabouts, as described in DMRB, are similar to ‘continental’ types, having single-lane entries and exits, but are tighter still. They are described as being suitable for roads of 40mph or below, with up to 8,000 vehicles per day. Importantly, the width of the circulatory carriageway is such that motor vehicles cannot overtake each other. Entries and exits should be tight, without flares, and the central island may need an overrun area to account for the movements of larger vehicles.

The Irish National Cycle Manual shows a similar model, the ‘Shared Roundabout’, with cycle symbols on the circulatory carriageway, but suggests that the maximum traffic flow for such a facility ought to be 6,000 vehicles per day.

5.5.6 Roundabouts with segregated cycle lanes

Unsegregated cycle lanes around the periphery of roundabouts are used in some European countries where drivers are accustomed to giving way when turning, but are very unlikely to operate in the same way in the UK and therefore not recommended for cycle routes.

In the UK, motorists are not accustomed to giving way on exit to other circulating vehicles and therefore need instruction and incentive to do so. TSRGD diagram 1003 (double dashed) and diagram 1023 (triangular) ‘give way’ road markings may help to promote that behaviour but, in order to reduce substantially risk of collision with cyclists, separation is recommended, effectively creating segregated lanes around the roundabout.

This leaves the problem of circulating cyclist priority over vehicles entering and exiting from the arms of the roundabout – a similar problem to the generic issue of lane or track priority across side roads (see section 5.3). Marking parallel cycle and pedestrian crossings across each arm in such a way that the cycle crossing aligns with the annular cycle lane is one way of addressing this issue. This will be available when the revised TSRGD comes into force in 2015. However, see section 5.2.10 for discussion of pedestrian crossings over cycle tracks and the potential need to stagger certain arrangements.



Roundabout with off-carriageway tracks in Amsterdam

‘Dutch style’ roundabout

A type of roundabout where cyclists are segregated from other road users with orbital cycle tracks has been trialled off-street by TfL. A ‘Dutch style’ roundabout of this sort has one general traffic lane with parallel cycle and pedestrian crossings on each arm, close to the roundabout itself, to minimise deviation of pedestrians from desire lines.

The geometry is arranged such that motor vehicles leaving the roundabout approach the crossings at an angle close to 90 degrees to maximise inter-visibility. The focus of the trial is on functionality and safety – ensuring that all users understand and use the roundabout in the way that is intended, particularly the various requirements to give way.

‘Dutch style’ roundabouts are a trial measure and the various components are yet to be tested on-street. Any proposal for a new or remodelled roundabout incorporating separation for cyclists and cycle and pedestrian priority on each arm should be discussed with TfL at an early stage. Outputs from the trials and any further testing will be added to this guidance when available.



Dutch style roundabout

5.5.7 Informal ‘roundabouts’

If well designed, removal of formal priority to bring about more cautious user behaviour (see section 3.4.8) can be applied at junctions to imply a roundabout – by incorporating circular patterns in the surface treatment. These are a flexible alternative to priority junctions in lower-traffic scenarios. There are no set dimensions for such a feature.

Where there is little traffic present, vehicles can progress through the ‘roundabout’ as they would at any priority junction. Where traffic is heavier, vehicles are encouraged by the appearance of the feature to act as if it were a roundabout and give way to the right. Informal roundabouts can be advantageous to cyclists, allowing them to progress through a junction without having to stop and start, and generally encouraging lower speeds.



Informal roundabouts at Moor Lane, City of London and Bexleyheath town centre, both of which have a ‘roundabout-like’ feature in the carriageway

5.5.8 Gyratories and one-way systems

Gyratories in London vary from area-wide one-way systems to large, ‘roundabout-type’ junctions. This variation in types means that each needs looking at on its own merits, as part of a wider network management approach. It is essential that an area-wide analysis takes place and that all opportunities for improvements of the local area and for better pedestrian accessibility are taken into account. The junction assessment tool (see chapter 2) can assist in analysing cycle movements through various junctions that may form part of a gyratory.

For cycling, the issues that gyratories and one-way systems present generally include the following:



- Little feeling of safety through close proximity to large volumes of fast-moving traffic and/or large vehicles – factors identified in chapter 2 as leading to particularly low levels of service for cyclists
- Lack of directness – one-way movement generally leads to longer journeys and does not allow cyclists to follow desire lines
- Lack of legibility – movement through such junctions tends not to be intuitive and requires extensive signing
- Intimidating road conditions – the prospect of moving across lanes of moving traffic to get into the appropriate road position

Gyratory redesign

Gyratory removal and a return to two-way working, although likely to be a major project, is an option that can help address the above issues. It is more intuitive, likely to be lower speed, almost always leads to more direct journeys and can enliven and ‘humanise’ streets that previously were blighted by fast-moving bursts of one-way traffic, helping to foster a more diverse range of active street and land uses.

The focus of any gyratory redesign should be on enabling more direct journeys with less delay, particularly for pedestrians and cyclists, and on allowing more ‘conventional’ approaches to be

taken to cycling provision and to management of motor traffic speed and volume. This may only entail part-removal or partial remodelling of a gyratory or one-way system.

Return to two-way working

Other selected interventions can also be made to improve conditions for cyclists. Taking a filtered permeability approach and allowing cyclists to make movements that are banned for other vehicles, together with opening up one-way sections to contraflow cycling, are of obvious benefit for cyclists from a coherence and

directness perspective. However, care needs to be taken to avoid putting cyclists into conflict with fast-moving opposing traffic. A higher degree of separation, such as use of full or light segregation, might be appropriate in such cases.

Where one-way systems are likely to remain, and where space is available, an opportunity exists to run cyclists in contraflow around much of the system. This can constitute a high level of service, provided each junction within the system is designed so as to minimise conflicts and delays for cyclists. It can help in avoiding issues related to integration with bus infrastructure.



General traffic lane converted to off-carriageway tracks at Wandsworth Gyratory

Bibliography

- [Design Manual for Roads and Bridges TD50/04](#) (2004)
- TfL [Design standards for signal schemes SQA064](#) (2014)
- Department of the Environment, Transport and the Regions [Guidance on the use of tactile paving surfaces](#) (1998)
- [Highway Code](#)
- TRL [Infrastructure and Cyclist Safety](#) (2011)
- DfT [LTN 2/08: Cycle Infrastructure Design](#) (2008)
- DfT [LTN 2/95, Design of Pedestrian Crossings](#) (2012)
- DfT [LTN1/95, Assessment of Pedestrian Crossings](#) (2012)
- DfT & DCLG [Manual for Streets](#) (2007)
- TfL [Pedal cyclist collisions and casualties in Greater London](#) (2011)
- TRL [PPR 436, Literature review of road safety at traffic signals and signalised crossings](#) (2009)
- TRL [PPR240, Behaviour at advanced cycle stop lines](#) (2005)
- TRL [PPR703: Trials of segregation set-back at side roads](#) (2014)
- TRL [Shared Zebra Crossing Study](#) (2006)
- DfT [Signing the Way](#) (2011)
- DfT [TAL 10/93, Toucan: an unsegregated crossing for pedestrians and cyclists](#) (1993)
- DfT [TAL 4/98, Toucan crossing development](#) (1998)
- DfT [TAL 9/97, Cyclists at roundabouts: continental design geometry](#) (1997)
- DfT [TAL5/05 Pedestrian facilities at signal-controlled junctions](#) (2005)
- DfT [Traffic Advisory Leaflet 1/06, General principles of traffic control by light signals, 2006, Part 1](#) (2006)
- One Road Network [Traffic modelling guidelines \(version 3\)](#) (2010)
- DfT [Traffic Signs Manual](#) (2003)
- AECOM [Traffic Signs Policy Review: Research Project into the Awareness of the Meaning of Traffic Signs Project PPRO 04/16/24](#) (2011)
- [Zebra, Pelican and Puffin Pedestrian Crossings Regulations and General Directions](#) (1997)