

Transport for London
Property

Design Principles

MAYOR OF LONDON



TRANSPORT
FOR LONDON

EVERY JOURNEY MATTERS

Transport for London
Property

Design Principles

Good design is fundamental to a high quality city

Intelligent commissioning and a commitment to design excellence are central tenets in the creation of high-quality spaces and places for all Londoners. They are an essential means of ensuring Good Growth by Design, of maximising long-term value for money, creating sustainable places and widening public participation in projects.

For us, design quality, in all its guises, underpins every stage of the commissioning process, and this document sets out our strategy for achieving this. At the heart of this is a set of design principles against which all our developments will be measured and tested.

In the future we want to be able to celebrate the contribution our projects make to the life of the city. Taking care over the quality of our designs now, we can ensure that in 50 years' time, people truly enjoy living, working and playing in and around our buildings. We will act as long term stewards of these public assets in a way that puts people at the heart of development.

Building on a legacy of design excellence

Our legacy of design excellence is founded on the development of strong principles, from Frank Pick's ideology of moral and civil harmony achieved through the integration of art and design, to Roland Paoletti's six spatial and social principles for the development of the Jubilee Line extension. Facing a different challenge of delivering mixed-use projects on our land, and as a response to the six pillars of Good Growth by Design, we have created our own set of design principles.

These principles have been carefully designed for our development projects. They are specific to the task of delivering on our land, and cover a balance of spatial, social and environmental issues. They set a consistent and clear tone whilst being open to creative interpretation and different outcomes. They are pragmatic, focused on the ways that design adds value to development at all stages, and they are long lasting, relevant to the future of a growing city.

How to use this document

These design principles set a tone for how the design of a development should be managed. All projects should be able to respond to and achieve all of the principles, though it will be down to the creativity of individual project teams to find ways of making the principles specific to individual sites.

This document is set out in layers. At the highest level are the individual principles, followed by their four design questions. After this are a series of criteria and works required to support the interpretation of each principle, accompanied by an illustration of the ways that these criteria should be considered. The final section of this book sets out the current set of supporting documents and the ways in which they should be used.

Contents

Part 1 — Design Principles

Principle 1	
Purposeful, generous and curated places	p. 10
Principle 2	
Relate to and strengthen their neighbourhoods	p. 16
Principle 3	
Places that evolve over time	p. 22
Principle 4	
Places people are proud to live in	p. 30
Principle 5	
Celebrate the qualities of urban living	p. 36
Principle 6	
Founded on transparent engagement and best practice	p. 42

Part 2 — Supporting Documents

Programme	p. 50
Sustainability Framework	p. 52
Design Review	p. 54
Feasibility	p. 55
Heritage	p. 56
Community Engagement	p. 58
Additional Resources	p. 60

Part I

Design Principles

Design Principles

The principles are set around two overarching values that embody how we approach development. Each value is supported by six design principles that are at the core of our work, and the ambitions that we set ourselves and our development partners.

Each principle is further developed as a series of questions that individual schemes should be able to answer convincingly, with checklists of work that may be required to support these answers.

All projects should work with and meet the principles. They will be used to test design proposals at all stages, from early feasibility work through to competitive bids, from planning applications to construction drawings. They will be part of the briefing to design teams, incorporated into procurement documents, passed on to planning authorities and given to design review panels.

Long term stewardship of public assets

- 1 Purposeful, generous and curated places
- 2 Relate to and strengthen their neighbourhoods
- 3 Places that evolve over time

People at the heart of development

- 4 Places people are proud to live in
- 5 Celebrate the qualities of urban living
- 6 Founded on transparent engagement and best practice

Long term stewardship of public assets

Principle 1 — p. 10
Purposeful, generous
and curated places

Principle 2 — p. 16
Relate to and strengthen
their neighbourhoods

Principle 3 — p. 22
Places that evolve
over time

Principle I — Purposeful, generous and curated places



Our developments will be purposeful, generous and curated places. Their design and layout will reflect the way that people use them everyday, contributing to the life of the street, supported by well considered public realm.

①

Has the scheme been designed from the street first?

②

Do all spaces have a purpose?

③

Are there moments of generosity in the scheme?

④

Is there a public realm strategy focussed on improving quality of life?

Criteria

Projects will be a part of their neighbourhood, and have an active and legible street connection, sometimes extending into streets within the development. All spaces within the scheme, and those at the edges, will have a purpose. We will create public realm strategies, where all decisions improve the quality of life for those interacting with the development. We will explore movement across the site, finding places to stop and dwell, with a clear hierarchy that identifies the spaces essential to the social life of the scheme. Fundamental to this is are moments of generosity. These do not need to be grandiose, instead they should work creatively to improve the overall quality of a place. This could include focussing on entrance areas, the choice of material on a key façade or making a wider connection.

The following key criteria should be addressed to help support this principle:

- 1 Has the scheme been designed from the street first?**
- (A) Local street plan and urban grain analysis through a variety of mapping techniques
- (B) Hierarchy of streets and public spaces across the site
- (C) Block layout and entrances designed from the point of view of pedestrians, and from the outside in
- (D) Completed Healthy Streets checklist

2 Do all spaces have a purpose?

- (E) Landscaping plans and briefs developed at early stages
- (F) Clear identity for each space in the scheme
- (G) Joyful spaces identified and celebrated

3 Are there moments of generosity in the scheme?

- (H) Hierarchy of spaces mapped out across the scheme
- (I) Qualities and characters of individual spaces described rigorously
- (J) A small number of spaces highlighted as key to the social life of the development

4 Is there a public realm strategy focussed on improving quality of life?

- (K) Landscaping that encourages dwelling and improves outlook of homes
- (L) Resilient and context driven planting strategy
- (M) Simple maintenance plan that will keep the public realm improving over time

Required studies and drawings

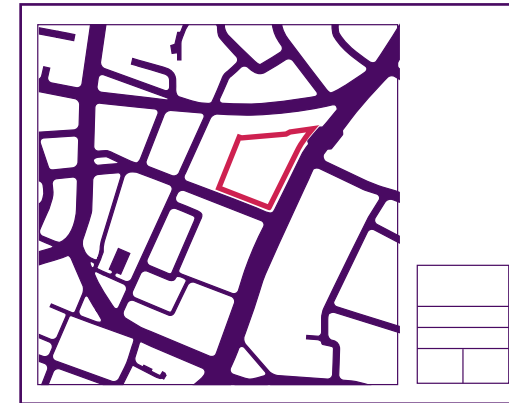

(A)

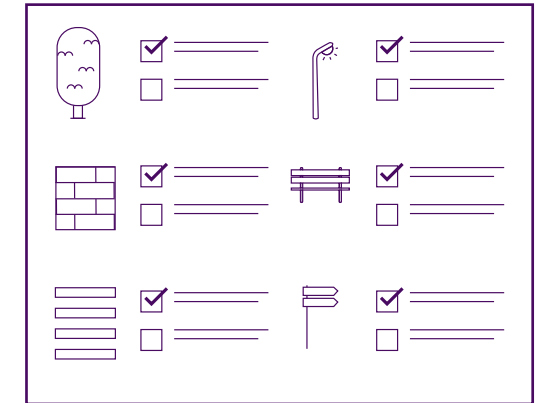

(D)



(A)

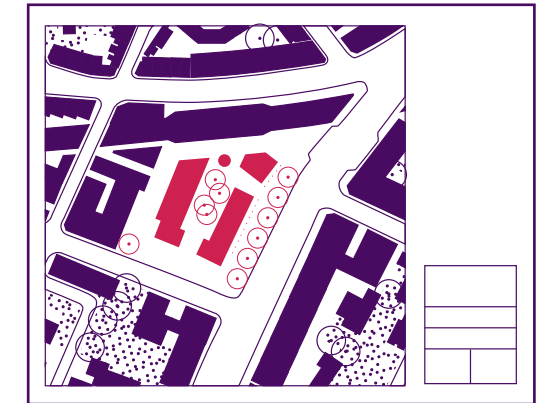

(E)

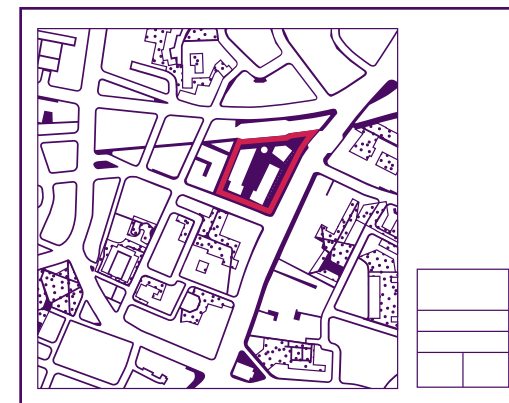

(B)



- (C) Block layout and entrances designed from the point of view of pedestrians, and from the outside in
- (D) Completed Healthy Streets checklist
- (F) Clear identity for each space in the scheme
- (G) Joyful spaces identified and celebrated
- (H) Hierarchy of spaces mapped out across the scheme
- (I) Qualities and characters of individual spaces described rigorously
- (J) A small number of spaces highlighted as key to the social life of the development
- (K) Landscaping that encourages dwelling and improves outlook of homes
- (L) Resilient and context driven planting strategy
- (M) Simple maintenance plan that will keep the public realm improving over time

Principle 2 — Relate to and strengthen their neighbourhoods

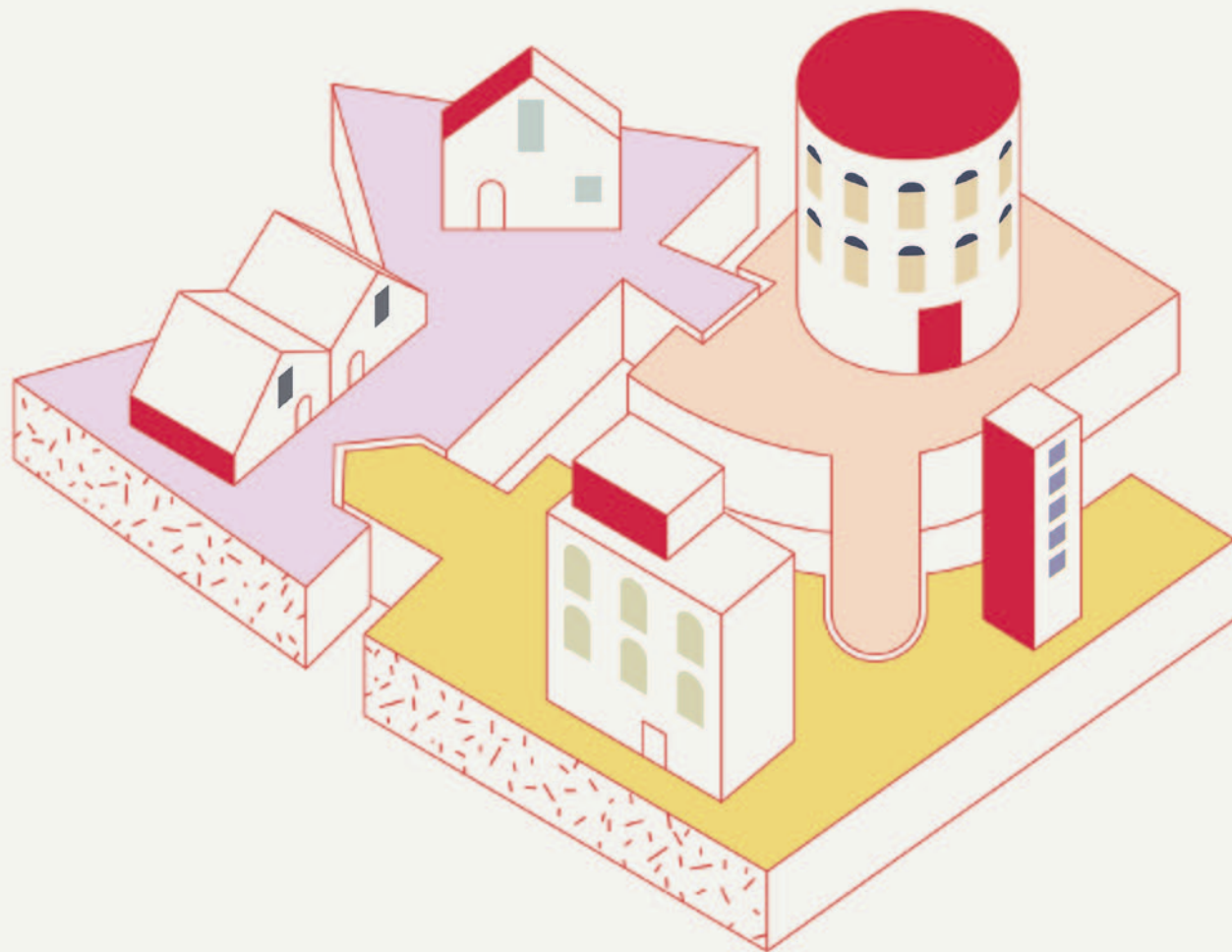

Our developments will relate to and strengthen their neighbourhoods. They will be designed to respond positively to existing context and communities, actively supporting and embedding themselves within their environment.

①

Have the local communities, social history and architectural characters been analysed?

②

Does the development form a reciprocal relationship with its local context?

③

Is the scheme designed in the round?

④

Are the thresholds between public, communal and private spaces legible?

Criteria

We will investigate the social history, communities and spatial character of the place we are joining. This will help make sure that our proposals build on what already exists, forming reciprocal relationships with the local area. This could be through massing, ground floor uses, or a housing offer that suits local need. Developments will not look like a copy of the current context, they will find a way of connecting to what is already happening, unlocking and reinforcing existing local qualities. This will mean carefully considering the thresholds between public, communal and private space, designing these to encourage residents to join their new neighbourhood. Many of our sites are visible on all sides, perhaps overlooking train tracks or back gardens, and so developments will be designed in the round, showing consideration of all aspects, and from all viewpoints.

The following key criteria should be addressed to help support this principle:

1 Have the local communities, social history and architectural characters been analysed?

- (A) Diagrams, maps and historic research analysed
- (B) Accurate walking and cycling distances (not radius diagrams) showing connectivity before and after
- (C) Local community groups and interests identified and mapped

2 Does the development form a reciprocal relationship with its local context?

- (D) Massing and scale responds to current and emerging context
- (E) Ground floor uses and housing mix responds to local and projected demand
- (F) Local social infrastructure identified and supported where necessary
- (G) Connections within neighbourhood unlocked
- (H) Sections drawn through all boundary conditions

3 Is the scheme designed in the round?

- (I) Elevations developed from all sides
- (J) Careful hierarchies of front and back, public and private
- (K) Boundaries analysed and architectural responses adopted
- (L) View from the train and platform developed

4 Are the thresholds between public, communal and private spaces legible?

- (M) Landscape led site plans with a clear hierarchy of spaces and journeys
- (N) Mapping of pedestrian routes and flows and servicing routes
- (O) Main entrances to be a 'handshake to the street'

Required studies and drawings

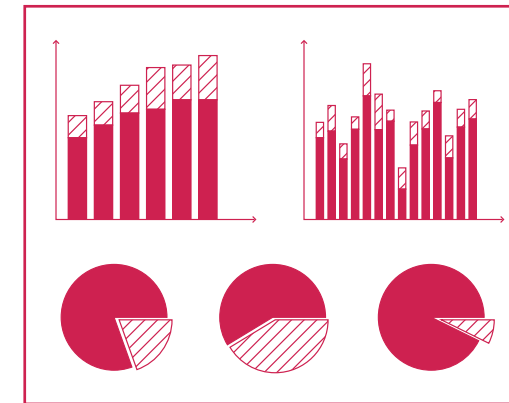

(A)

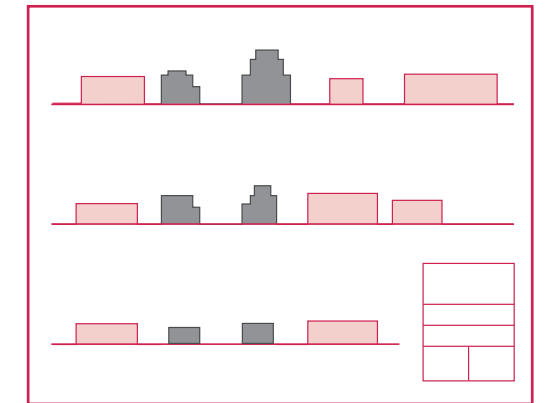

(D) (H)

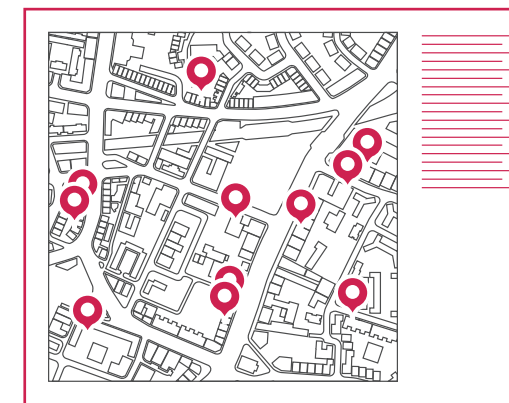

(C)

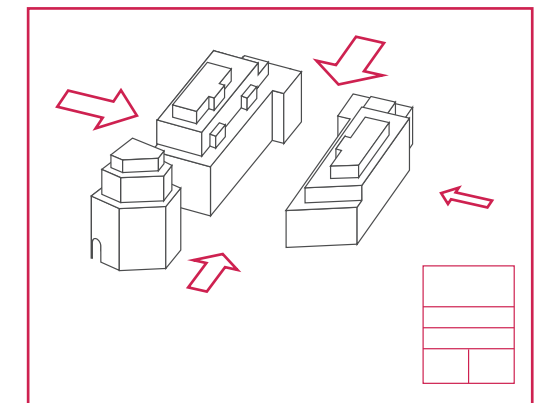

(I) (J)

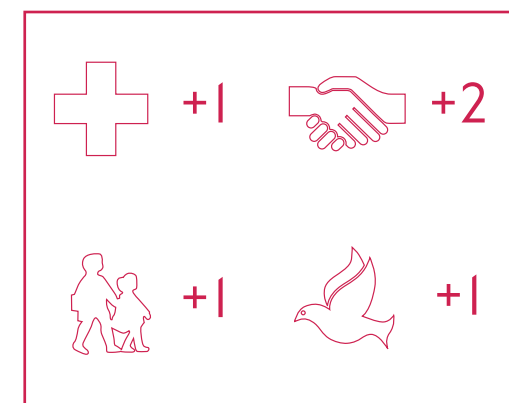

(F)

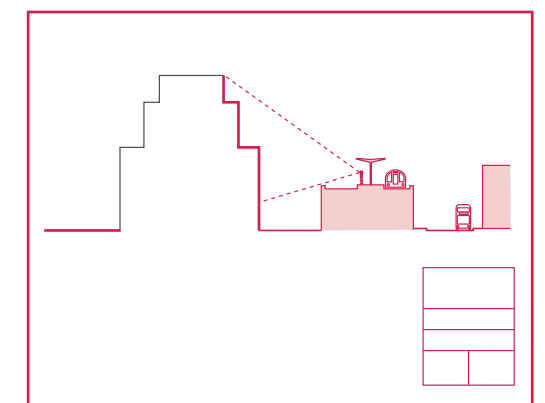

(K) (L)

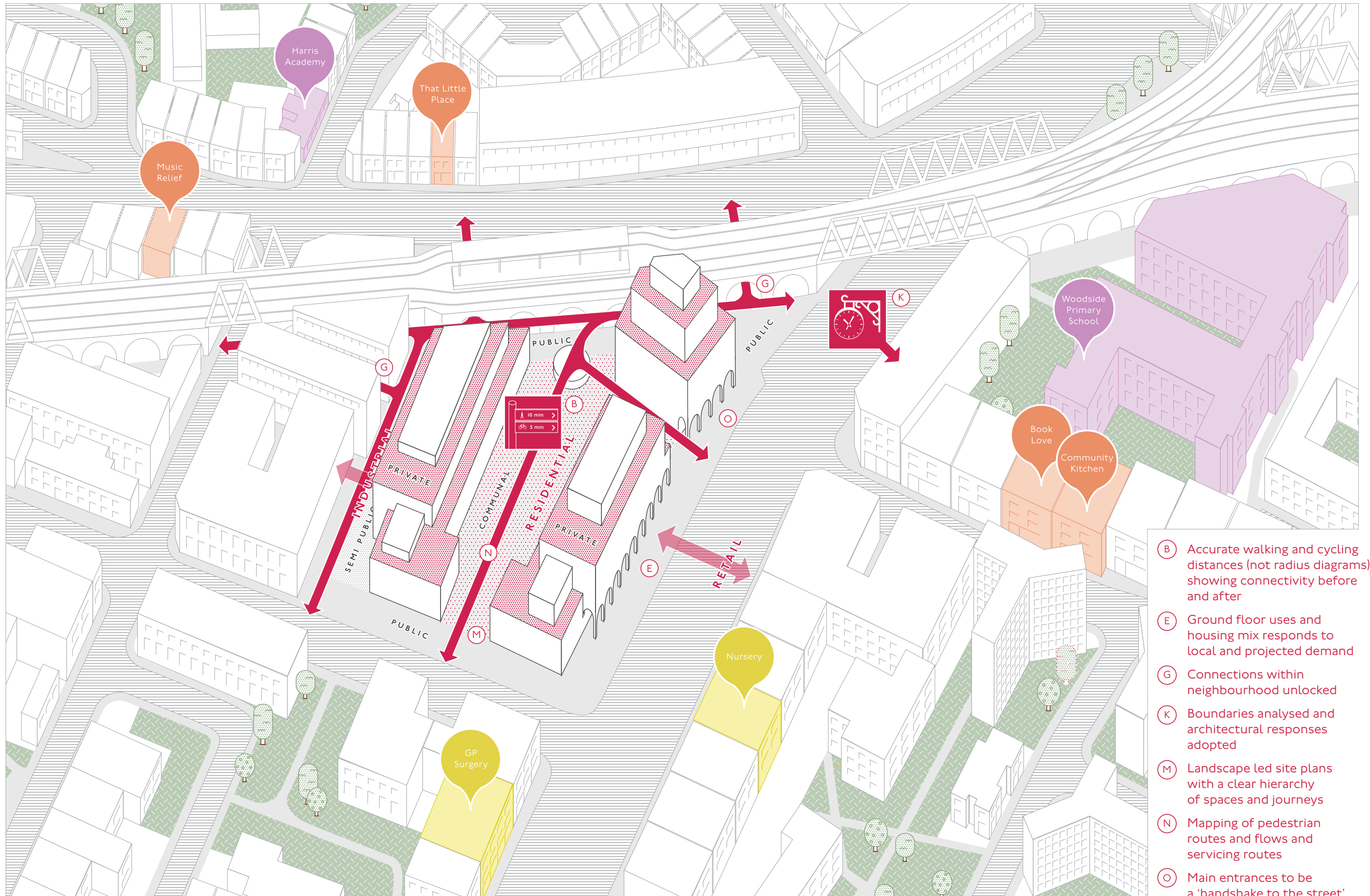

- (B) Accurate walking and cycling distances (not radius diagrams) showing connectivity before and after
- (E) Ground floor uses and housing mix responds to local and projected demand
- (G) Connections within neighbourhood unlocked
- (K) Boundaries analysed and architectural responses adopted
- (M) Landscape led site plans with a clear hierarchy of spaces and journeys
- (N) Mapping of pedestrian routes and flows and servicing routes
- (O) Main entrances to be a 'handshake to the street'

Principle 3 — Places that evolve over time

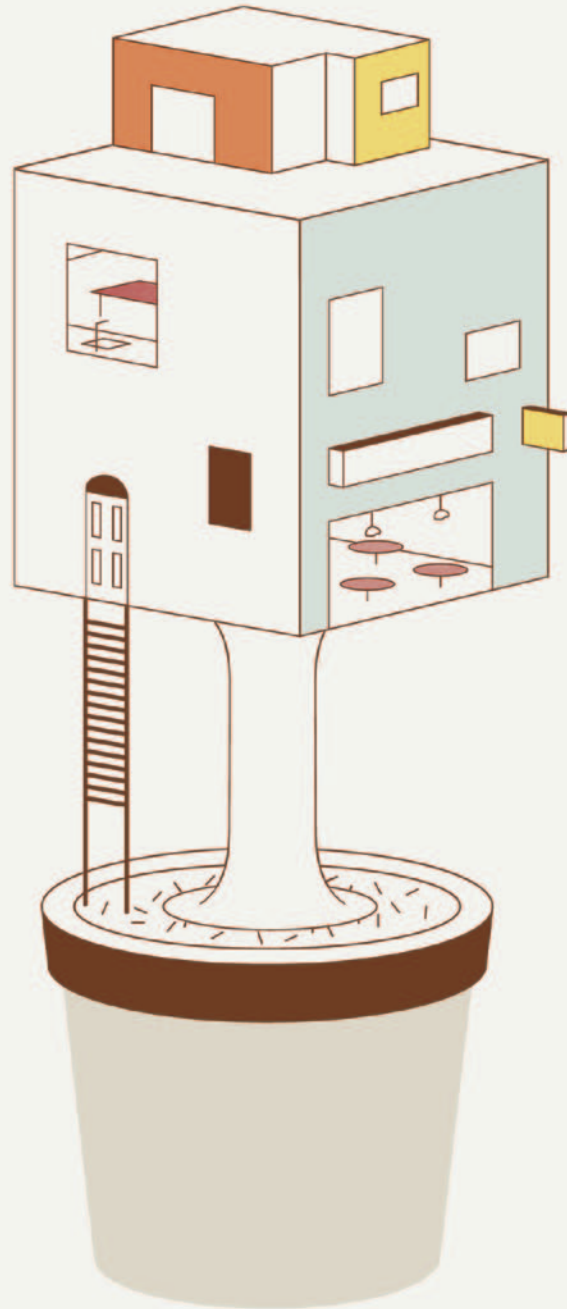

Our developments will be places that evolve over time. They will improve as they bed into their neighbourhoods, and our care in public realm design and material specification will mean they age gracefully.

①

What single characteristic will define the scheme in the future?

②

Will the public realm continuously improve over time?

③

Will the development look good in 50 years time?

④

Does the scheme provide flexibility to sustainably adapt to changing markets and contexts?

Criteria

Our schemes will become better as they embed themselves into their neighbourhoods. At a fundamental level the public realm, planting of trees and placing of street furniture, should be something that grows into itself. At a wider level the development should have a character or characteristic that defines it, whether it is the way the place is described by locals, or part of the offer it makes back to a place over time. All of this should be considered in terms of what will be there in fifty years time, how the materials and spaces will be maintained, how they will age, and how they can be easily repaired. This is also about providing flexibility to meet the needs of different economic climates, and adapt to changing local needs. The design process will be used as a way of testing what the future of a place could be, and making sure that development supports this.

The following key criteria should be addressed to help support this principle:

1 What single characteristic will define the scheme in the future?

- (A) Strategic vision, clearly and succinctly expressed
- (B) Strong site specific development principles
- (C) Clearly identifiable character that responds to local context
- (D) Benchmarking of proposals against global precedents

2 Will the public realm continuously improve over time?

- (E) Specification of hard wearing materials
- (F) Resilient planting that is mature on day of installation
- (G) Costed maintenance plans for the public realm and landscaping

3 Will the development look good in 50 years time?

- (H) Specific design and character principles describing the scheme's aesthetic
- (I) Material specification and detailing that prioritises longevity and quality
- (J) Analysis of the surrounding context in terms of future developments

4 Does the scheme provide flexibility to sustainably adapt to changing markets and contexts?

- (K) Economic sustainability strategy looking at different possible futures
- (L) Options testing clearly demonstrating possible evolution of the scheme
- (M) Life cycle and circular economy modelling looking at maintenance, replacement and demolition
- (N) Ground floor strategy with built in flexibility

Required studies and drawings

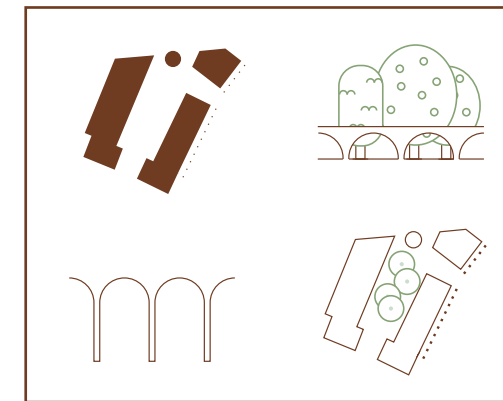

(A) (B)

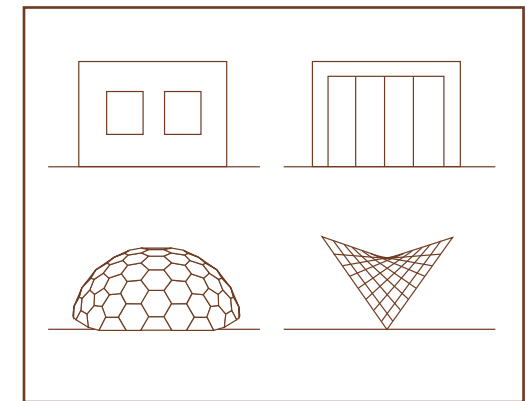

(L)

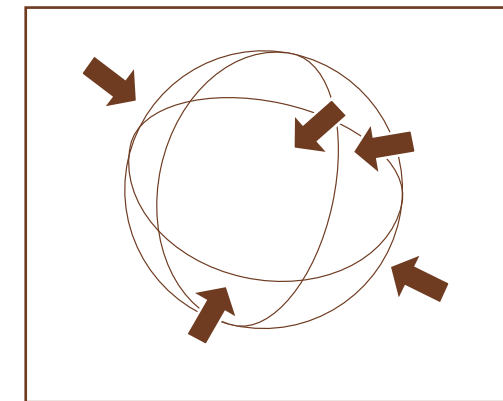

(D)

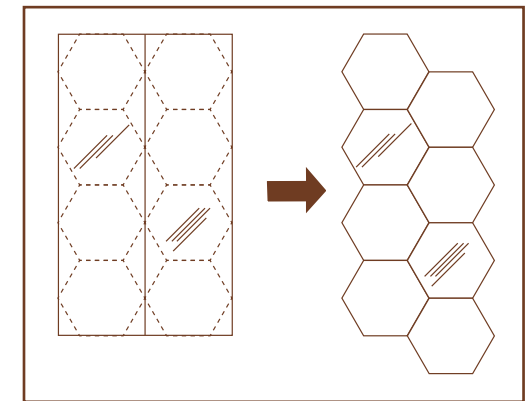

(M)

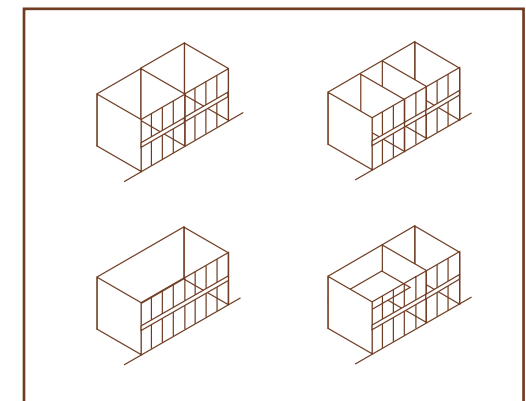

(N)

- (A) Strategic vision, clearly and succinctly expressed
- (B) Strong site specific development principles
- (C) Clearly identifiable character that responds to local context

- (E) Specification of hard wearing materials
- (F) Resilient planting that is mature on day of installation
- (G) Costed maintenance plans for the public realm and landscaping

- (H) Specific design and character principles describing the scheme's aesthetic
- (I) Material specification and detailing that prioritises longevity and quality
- (J) Analysis of the surrounding context in terms of future developments

- (K) Economic sustainability strategy looking at different possible futures
- (L) Options testing clearly demonstrating possible evolution of the scheme
- (M) Life cycle and circular economy modelling looking at maintenance, replacement and demolition
- (N) Ground floor strategy with built in flexibility

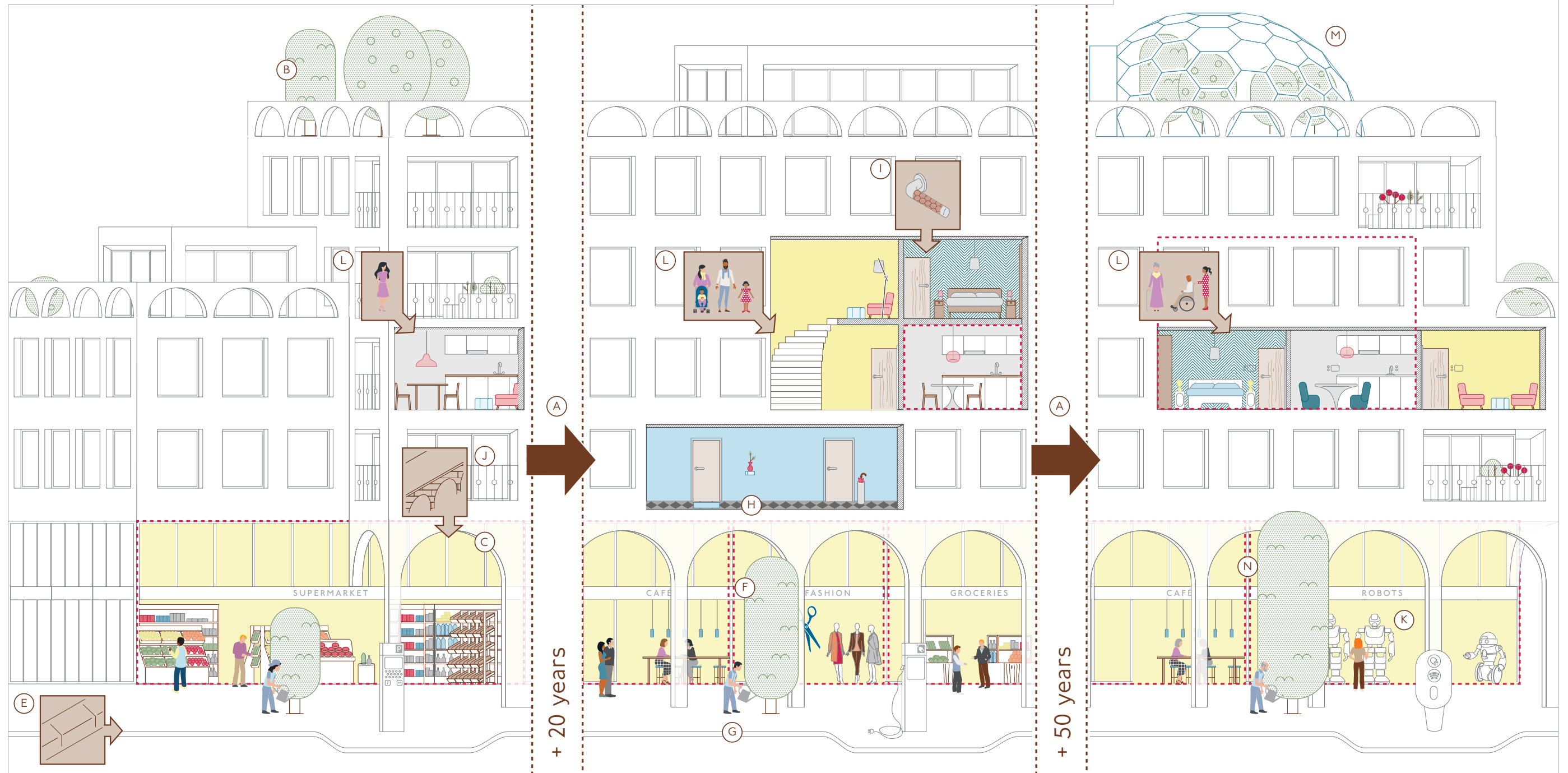
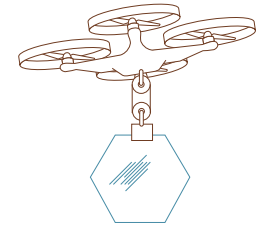

People at the heart of development

Principle 4 — p. 30
Places people are proud to live in

Principle 5 — p. 36
Celebrate the qualities of urban living

Principle 6 — p. 42
Founded on transparent engagement and best practice

Principle 4 — Places people are proud to live in



Our developments will be places people are proud to live in. We will create high quality places with the amenities that can support communities, and design that encourages people to be themselves.

①

Are the communal spaces high quality?

②

Does the scheme create adaptable platforms for peoples' lives?

③

Are the homes flexible for residents throughout their lives?

④

Is the development safe and secure?

Criteria

We will consider what it is that makes people proud to live somewhere: high quality amenity, resilient materials designed to last, and focus on the things that people touch and see. Well proportioned windows, balconies and gardens will allow people to personalise their spaces. Internal layouts and varieties of homes on each site will mean that they are flexible for residents throughout their lives. A variety of commercial and public spaces will be designed to support the existing communities as populations in the area increase, giving neighbouring residents something to take pride in too. Key to all of this is developing places that people feel a strong sense of ownership over, one they belong in. This will make sure that all spaces are safe and secure, encouraging people to feel the freedom to be themselves at home and with their neighbours.

The following key criteria should be addressed to help support this principle:

- 1 Are the communal spaces high quality?**
- (A) High quality, resilient and long lasting materials in key communal areas, for example entrances, lifts, lobbies and corridors
- (B) A particular focus on the objects that people touch everyday
- (C) Perspective views of communal areas and entrance sequences

2 Does the scheme create adaptable platforms for peoples' lives?

- (D) Balconies with built in planters
- (E) Roof terraces as amenity spaces where possible
- (F) Active frontages on all sides
- (G) High quality communal spaces
- (H) Flexibility of ground floor uses

3 Are the homes flexible for residents throughout their lives?

- (I) Variety of homes and tenures
- (J) Layouts suitable for different living arrangements
- (K) Consideration of multiple occupancy and multi-generational living
- (L) Fully accessible and adaptable systems at policy levels

4 Is the development safe and secure?

- (M) Clear distinctions between public, communal and private spaces
- (N) Design that encourages freedom and expression in private and communal spaces

Required studies and drawings

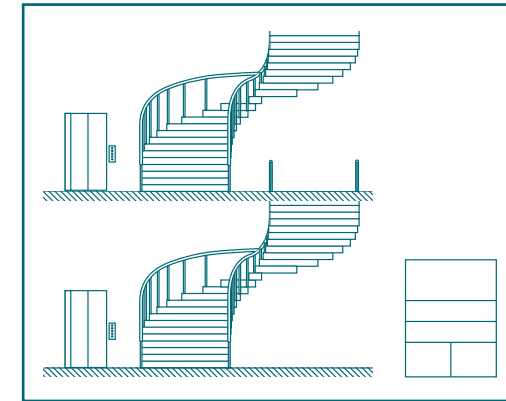

(C)

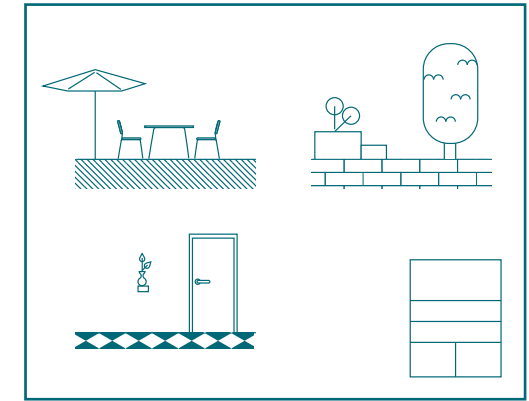

(M)

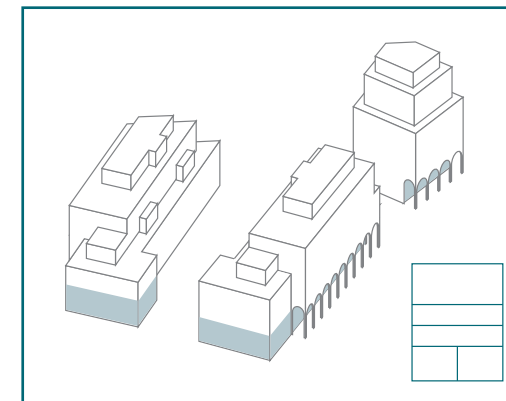

(F)

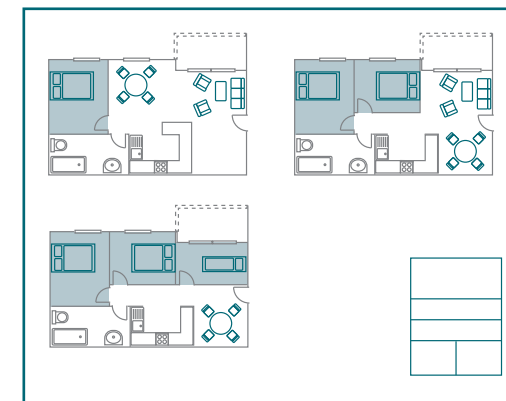

(I)

- (A) High quality, resilient and long lasting materials in key communal areas, for example entrances, lifts, lobbies and corridors
- (B) A particular focus on the objects that people touch everyday

- (D) Balconies with built in planters
- (E) Roof terraces as amenity spaces where possible
- (F) Active frontages on all sides
- (G) High quality communal spaces
- (H) Flexibility of ground floor uses

- (J) Layouts suitable for different living arrangements
- (K) Consideration of multiple occupancy and multi-generational living
- (L) Fully accessible and adaptable systems at policy levels

- (M) Clear distinctions between public, communal and private spaces
- (N) Design that encourages freedom and expression in private and communal spaces

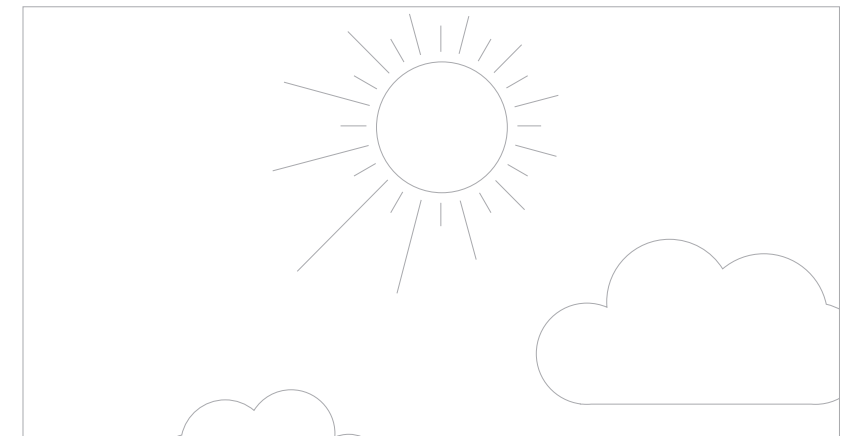

**Principle 5 —
Celebrate the qualities
of urban living**



Our developments will celebrate the qualities of urban living. They will be schemes that contribute to London, with their own distinctive high quality of life.

- ① Will the scheme provide a high quality of life?
- ② Does the scheme celebrate movement and connectivity?
- ③ Are there places for meeting and dwelling?
- ④ Are structures in place to support new communities in the development?

Criteria

Projects will understand the best bits of living in, and being well connected, to a city. New communities will start to form within and around our developments, and we will design in support for this where we can, helping to integrate new residents into existing networks. Connections and movement are fundamental. We will use our expertise to unlock connectivity within neighbourhoods, celebrating movement by creating joyful and intuitive spaces that encourage sustainable forms of transport, accidental meetings, dwelling and playing.

The following key criteria should be addressed to help support this principle:

1 Will the scheme provide a high quality of life?

- (A) Detailed daylight / sunlight / wind studies assessing quality of life in homes and at ground level
- (B) Maximising dual aspect across developments
- (C) Mitigating against sound and air pollution at all stages
- (D) High quality external communal and private amenity spaces
- (E) Privacy and overlooking carefully considered

2 Does the scheme celebrate movement and connectivity?

- (F) Make urban connections across sites to specific destinations
- (G) Pedestrian and cycle movement diagrams
- (H) Celebrate the romance of transport infrastructure and TfL's design legacy
- (I) Perspective views towards trains, and a series of views from the platform to the front door

3 Are there places for meeting and dwelling?

- (J) Design of communal and public spaces encourages dwelling and meeting
- (K) Joyful and generous neighbourhood moments
- (L) Annotated plan and pedestrian flow diagrams

4 Are structures in place to support new communities in the development?

- (M) Community infrastructure plan at a series of scales
- (N) Community engagement team throughout project
- (O) Mapping of existing communities passed on to new residents
- (P) Maintenance and management strategies for shared spaces

Required studies and drawings



(A)

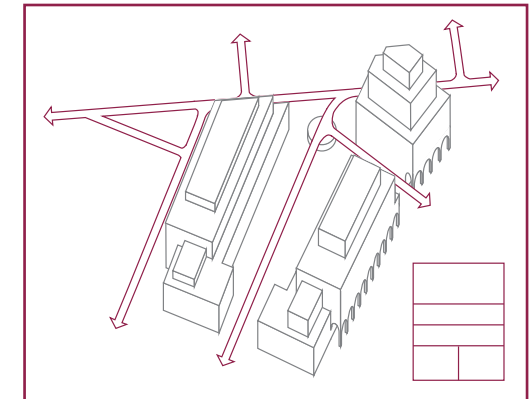

(G) (L)

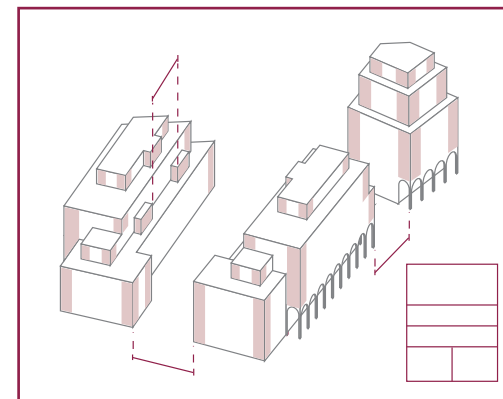

(B) (E)



(M)



- (B) Maximising dual aspect across developments
- (C) Mitigating against sound and air pollution at all stages
- (D) High quality external communal and private amenity spaces

- (F) Make urban connections across sites
- (H) Celebrate the romance of transport infrastructure and TfL's design legacy
- (I) Perspective views from the platform to the front door

- (J) Design of communal and public spaces encourages dwelling and meeting
- (K) Joyful and generous neighbourhood moments
- (L) Annotated plan and pedestrian flow diagrams

- (N) Community engagement team throughout project
- (O) Mapping of existing communities passed on to new residents

- (P) Maintenance and management strategies for communal and shared spaces

**Principle 6 —
Founded on transparent engagement
and best practice**



Our developments will be founded on transparent engagement and best practice. We value the knowledge and interest of the communities around our sites as a resource and relationship, and all of our schemes will be inspired by the best of the industry.

- ① Has the local community been engaged from the start?
- ② Have the social benefits of development been identified and agreed?
- ③ What kinds of innovation are being developed with this scheme?
- ④ Has knowledge been shared internally and externally?

Criteria

Wherever possible we will start engaging with local communities at the beginning of projects to help developments relate to their social context. If appropriate this will extend to identifying the specific social benefits that a project can bring. We see the value of our sites not only in what they can offer their immediate neighbourhood, but also in terms of the knowledge that we can develop or contribute to. Our developments will incorporate best practice, learning from exemplar projects and teams through site visits, talks and presentations. We see the development of this knowledge and expertise as part of our role as a public body, and will share our learnings where possible. As such we will try to test innovation at all sites, whether it is a form of Modern Methods of Construction, testing different housing typologies or an environmental innovation. What we learn will be shared within our team to help us build capacity, and will be communicated to stakeholders so that we all benefit.

The following criteria should be addressed to help support this principle:

1 Has the local community been engaged from the start?

- (A) Commence community engagement at feasibility stage and prepare project specific community engagement plan

2 Have the social benefits of development been identified and agreed?

- (B) Local and regional political engagement throughout a project
- (C) Local stakeholders engaged early to understand possible social benefits
- (D) Innovative social value of the scheme identified and agreed

3 What kinds of innovation are being developed with this scheme?

- (E) Use of Modern Methods of Construction and alternative housing typologies
- (F) Material or engineering innovations tested and celebrated
- (G) Sustainability and environmental innovations considered and tested

4 Has knowledge been shared internally and externally?

- (H) Internal workshops and peer reviews at all stages
- (I) Design workshops with partners and consultants
- (J) Learning afternoons for internal teams focussed on specific topics
- (K) Site visits to relevant projects with consultants, partners and stakeholders
- (L) Contributing to, and inviting, talks and presentations to industry

Required studies and drawings

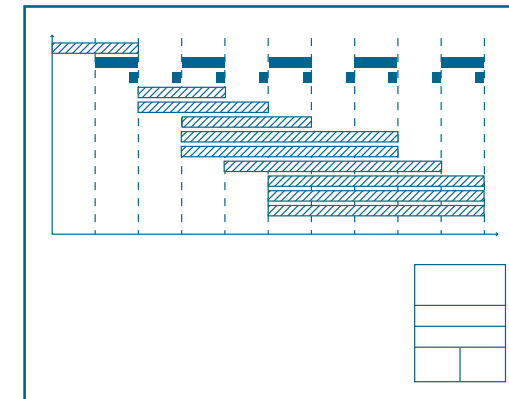

(A)

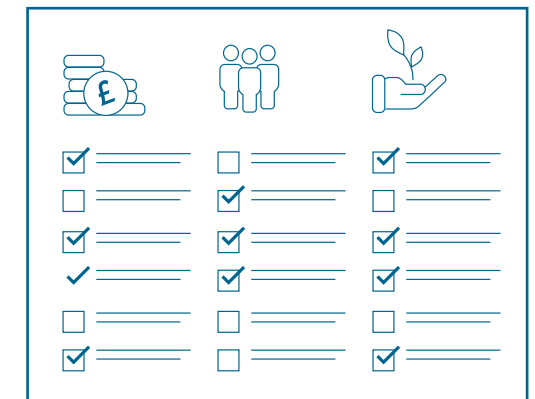

(G)

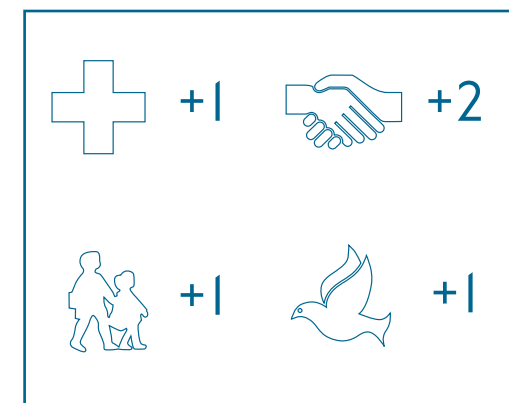

(D)

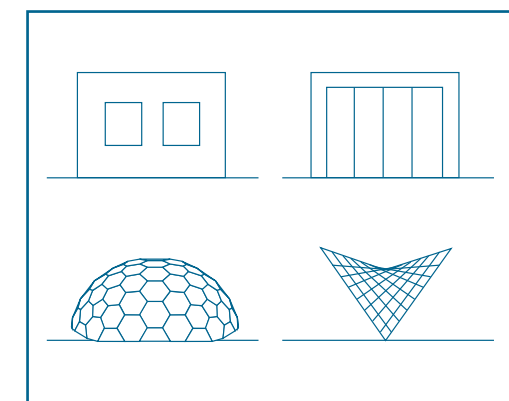

(E)

(F)

- (A) Commence community engagement at feasibility stage and prepare project specific community engagement plan
- (B) Local and regional political engagement throughout
- (C) Local stakeholders engaged early to understand possible social benefits
- (D) Innovative social value of the scheme identified and agreed

- (E) Use of Modern Methods of Construction and alternative housing typologies
- (F) Material or engineering innovations
- (G) Sustainability and environmental innovations considered and tested

- (H) Internal workshops and peer reviews at all stages
- (I) Design workshops with partners and consultants
- (J) Learning afternoons for internal teams focussed on specific topics

- (K) Site visits to relevant projects with consultants, partners and stakeholders
- (L) Contributing to, and inviting, talks and presentations to industry

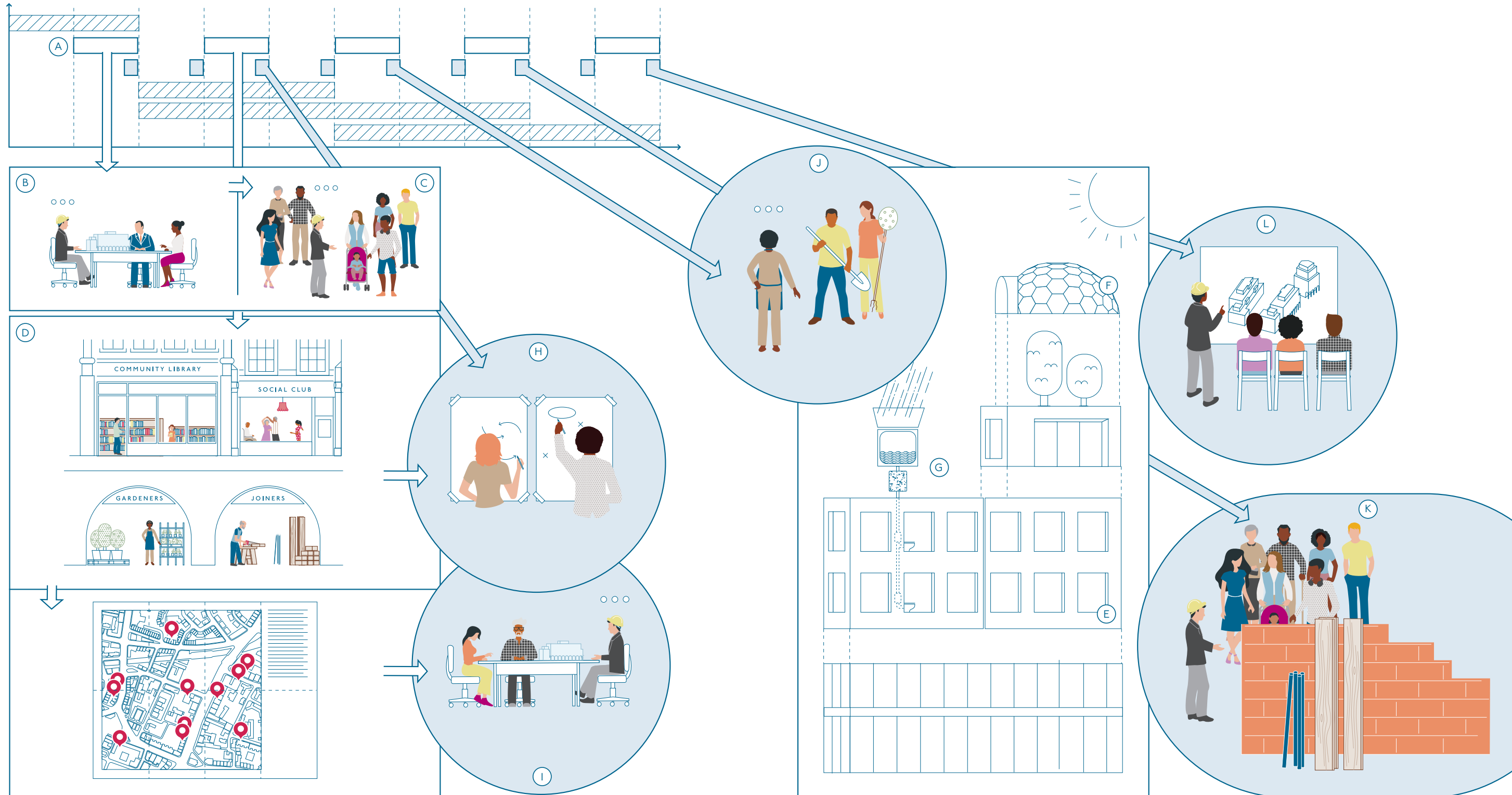

Part 2

Supporting Documents

Supporting Documents

Alongside these principles we have commissioned a series of best practice documents to provide more detailed guidance and support for our consultants and partners in creating great places. On the following pages a brief summary of each of these documents is provided, alongside an indicative project programme that highlights when these documents should be brought to bear.

Programme	p. 50
Sustainability Framework	p. 52
Design Review	p. 54
Feasibility	p. 55
Heritage	p. 56
Community Engagement	p. 58
Additional Resources	p. 60

Programme

Feasibility

Route to Market

Scheme Design

Detail Design

Construction

In-Use

Heritage



Baseline Study



Heritage Brief



Assess Bids

Sustainability



Performance Optimisation Brief



Assess Bids



Draft Performance Specification



Performance Review



Final Performance Specification



Performance Validation and Quality Control



Post Occupancy Evaluation

MDA Reviews

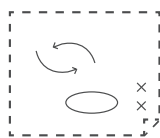

Optional 'Visioning' Review

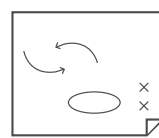

MDA 1

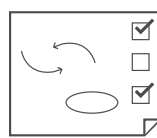

MDA 2 Assess Bids

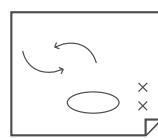

MDA 3

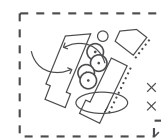

Chair's Review

Planning Application

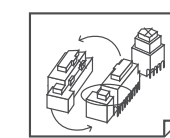

Detail Design Review

Community Engagement



Community Research



Engagement Strategy



Engagement during Tender



Assess Bids



Engagement Events



Statement of Community Involvement



Optional Events / Site Visits



Follow-up Research

Design Input



Prepare Design Brief



Tender Design Brief



Assess Bids



Precedent Visits

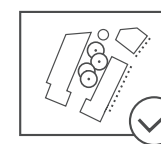

Design Sign Off

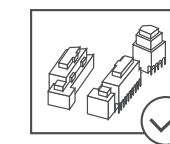

Material and Detail Sign Off



Team Site Visits



Team Site Visits

Sustainability Framework

Developed with technical advisory from Arup

We want to be leaders in sustainable development creating the best economic, environmental and social legacies possible for our new developments. We have combined an ambitious vision and strategy with performance metrics and quantitative targets into a tool for delivering best practice: the Sustainable Development Framework (SDF).

The framework spans nine dimensions of sustainability across the triple bottom line. Underpinning this is a metric-driven approach to optimising, specifying, delivering and monitoring best-in-class sustainable performance.

Each project will adopt a series of targets for each of the nine dimensions of sustainability. Project teams will consistently drive economic, social, and environmental performance throughout the entire development lifecycle to ensure that we create long-term value and a lasting legacy of positive change.

The six key objectives of the framework are as follows:

- 1 Achieve an intelligent balance of outcomes across the triple bottom line
- 2 Allow us to take control of the sustainability performance of our projects
- 3 Ensure partners and suppliers are aligned with, and committed to, our sustainability objectives
- 4 Establish a robust yet flexible framework that can be used to embed sustainable development best practice across all development projects
- 5 Specify and consistently achieve a baseline level of sustainability performance that puts us among the sector's leaders
- 6 Define a performance aspiration to work towards over time that redefines 'best in class'

Economic Dimensions



Sustainable Revenue
Infrastructure Delivery
Economic Development

Social Dimensions



Health and Wellbeing
Engagement and Inclusion
Liveable Communities

Environmental Dimensions



Building Performance
Healthy Streets
Green Infrastructure

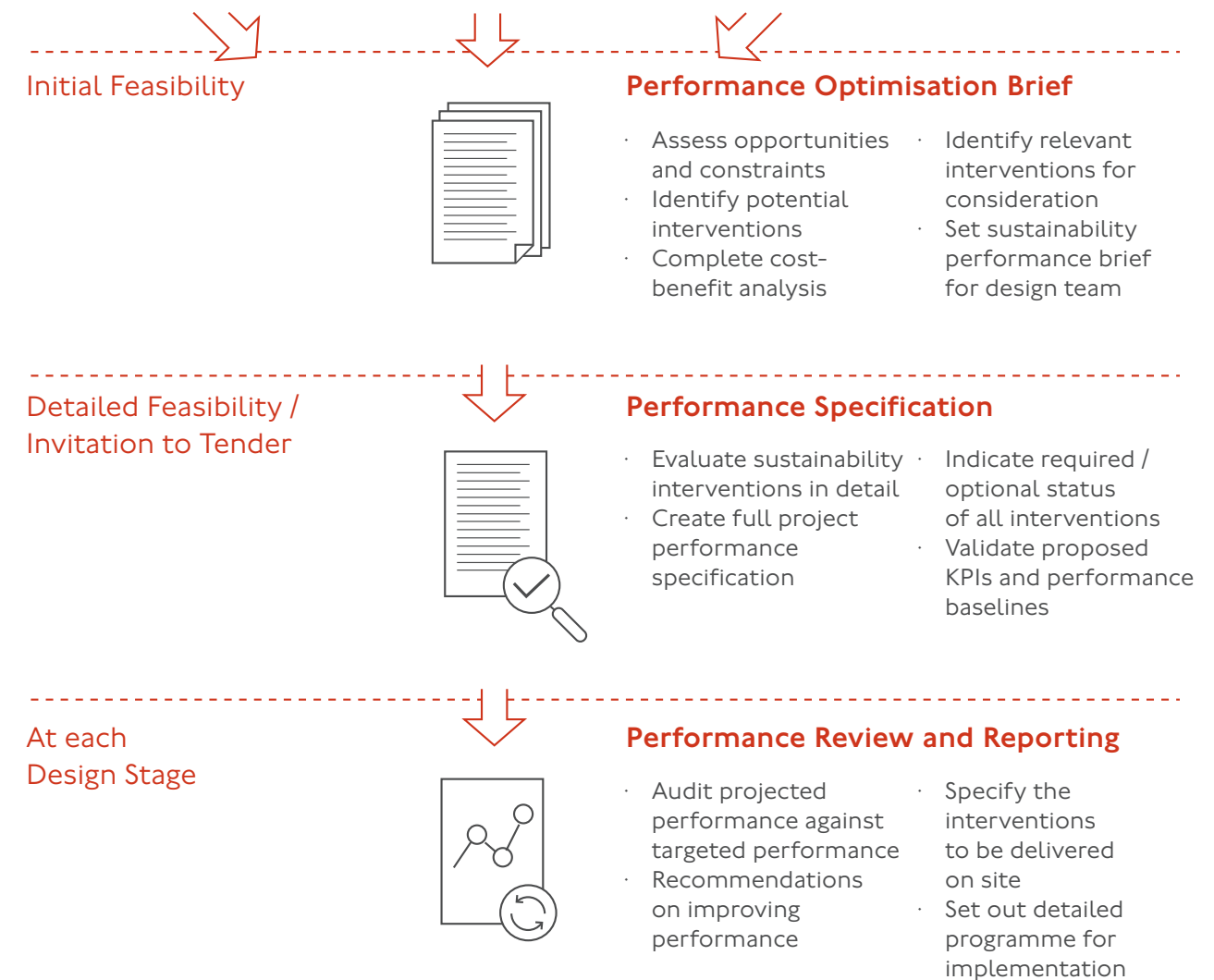

MDA Design Review Protocol

Developed with the GLA

Throughout a project's life we will test our emerging designs with a selection of the Mayor's Design Advocates. The Design Review protocol sets out reviews over three stages: early in the

feasibility study to help define the strategic vision for the site; once bids have been received from potential development partners; and once a partner has been selected.

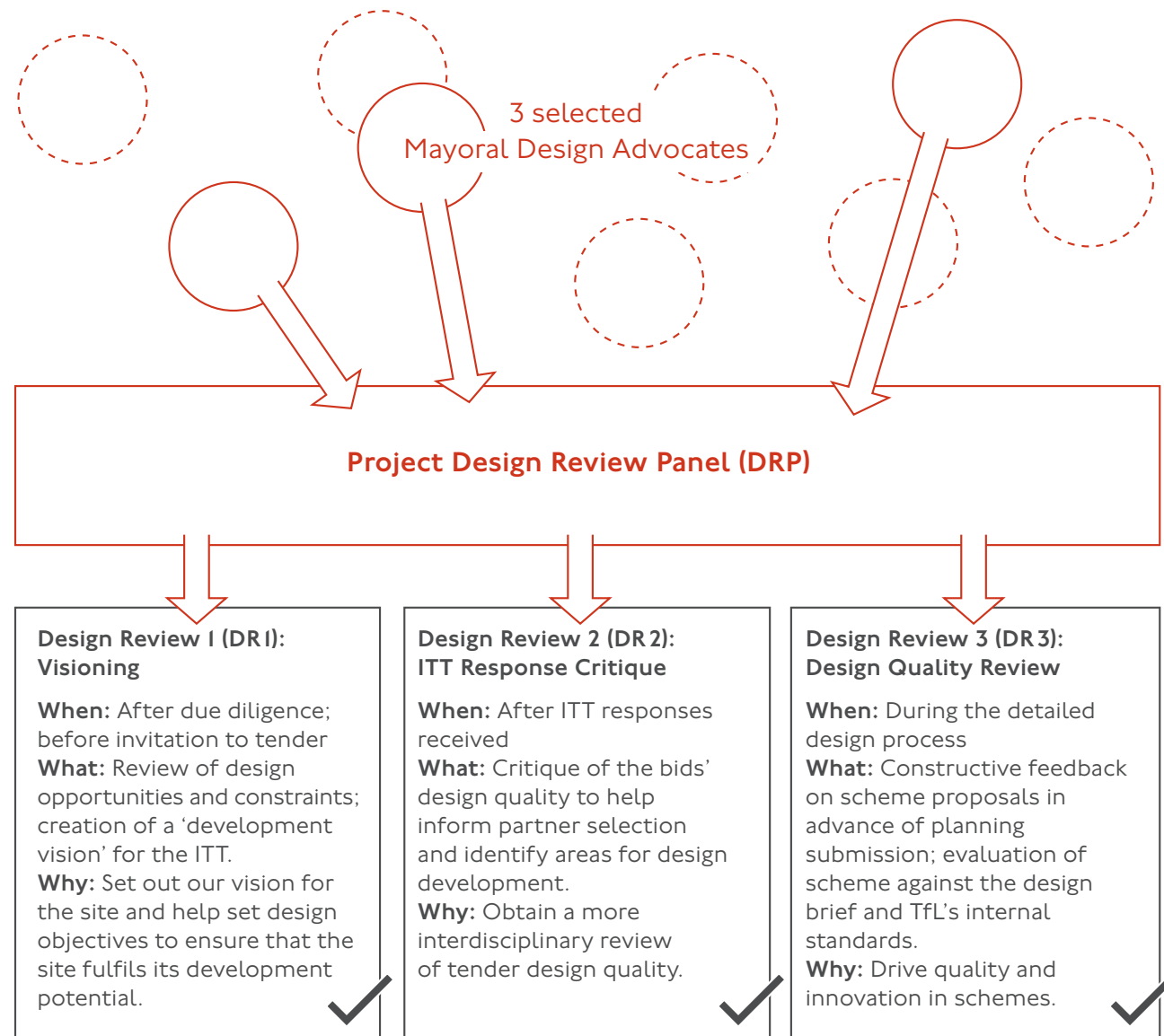

Feasibility Briefing Document

Developed with Publica

This document sets out our expectations in terms of the design portions of a feasibility study. It places a strong emphasis on design research and site analysis, and highlights the importance of developing a strategic vision for each site, as well as a series of site specific design principles that the project can be tested against.

The guidance has been drawn from the best examples of historic feasibility studies previously commissioned, and with the advice of the Mayoral Design Advocates in their role as reviewers of our schemes.

We see all development as integrated at a number of levels, with the wider city, down to connections with neighbouring streets and buildings, and this document outlines methodologies for conducting analysis and design research to make sure that future proposals will be able to integrate well.

Finally, there is a brief summary of our internal design review process, and how the information developed during the feasibility stages ties in to this.

Heritage Best Practice Note

Developed with Alan Baxter Associates

Our network, the Tube, the roundel, our graphic design and our iconic listed stations, buildings and structures are synonymous with London. We are custodians of this legacy, and with a number of our development opportunities close to these assets our designs should safeguard and improve them.

The Best Practice Note is a guide to architects, developers and others involved in the redevelopment of our estate to help sensitively manage change in and around the historic environment. The focus is on our many historic stations but the approach to understanding a historic place is applicable across our diverse estate including bus stations, car parks, land above new underground extensions and properties in and around station sites.

The best practice note identifies the following elements as essential to understanding the historic environment and informing the design of development:

- 1 Understanding the significance of the historic environment on and around the site.
- 2 Understanding the setting, including the relationship of the station or site with its wider townscape.
- 3 An integrated approach to design. This understanding should not only inform the early design process but be an integral part of it.

The second part of the guide sets out the history of each historic station group in more detail, identifying sub-groups for Underground stations. It also includes a table that identifies the origins of each of the 427 stations of the Underground and Overground, their historic group and urban typology. Architects and developers will be required to review the history of any station that they are seeking to develop in the vicinity of, to inform their understanding of significance.

Baseline stage

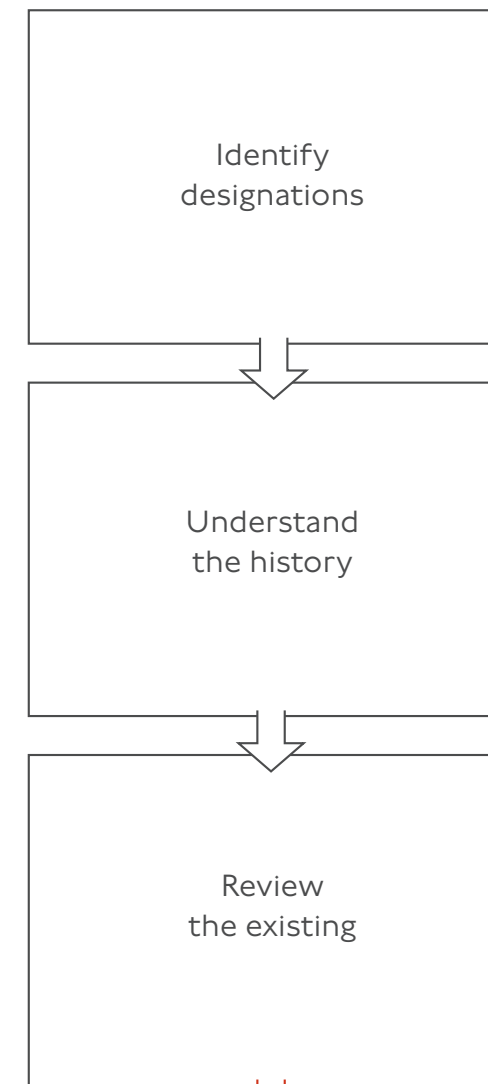

Identify any statutory designations

- Why is the structure listed
- Understand what is distinctive about the conservation area
- Identify and understand any other designated or non-designated heritage assets within the site

Understand the history of the place

- Understand the evolution of the building over time
- Understand the design intent of the architect, engineer or other designers

Review the existing station (or other building)

- Identify surviving features from previous phases of the building
- Identify any changes to the building and its urban context
- Record the building as existing
- Analyse the way the building is used
- Identify the relative significance of different parts of the building
- Identify any opportunities for enhancement

Design stage

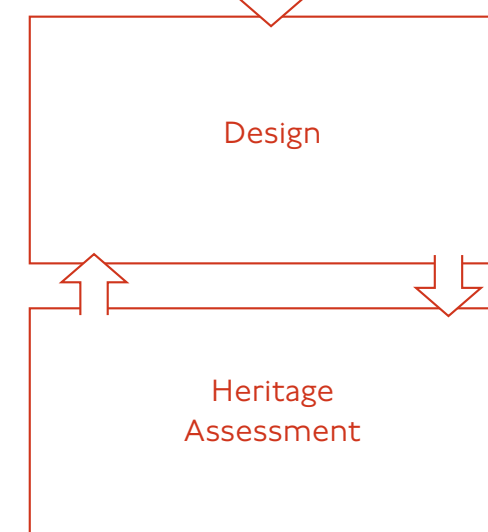

Understand the emerging designs and the following:

- Can the new development draw on the strengths of existing historic character?
- Can the new development improve movement, wider links, urban context and station functionality?
- Identify any harm to significance as well as any benefits
- Identify opportunities to mitigate harm and to enhance significance
- Demonstrate that any harm to the historic environment is outweighed by public benefits

Community Engagement Handbook

Developed with Daisy Froud

Good community engagement – well-designed, transparent, and introduced early in the process – can actively help the delivery of projects. This document provides a practical guide by setting out the principles of good engagement, including:

- 1 Advice for identifying community stakeholders
- 2 Improving understanding of community demographics
- 3 Planning and delivery of community engagement campaigns
- 4 Reporting on findings from engagement programme

The handbook goes hand in hand with our wider aspirations to ensure that engagement and consultation meet high standards, allowing Londoners to have a say in the future of their neighbourhoods.

All projects will develop their own bespoke community engagement strategy. This handbook sets out the method for creating this, alongside a step-by-step walk through of the essential and ideal elements of an engagement strategy.

At the heart of the handbook are 10 principles for good engagement, accompanied by advice on how to translate these into action. The final sections cover possible barriers to participation, and how to overcome them, alongside tips for effective outreach, and a small number of case studies to support best practice.

The handbook is designed to fit neatly into a pocket, offering an easily usable resource.

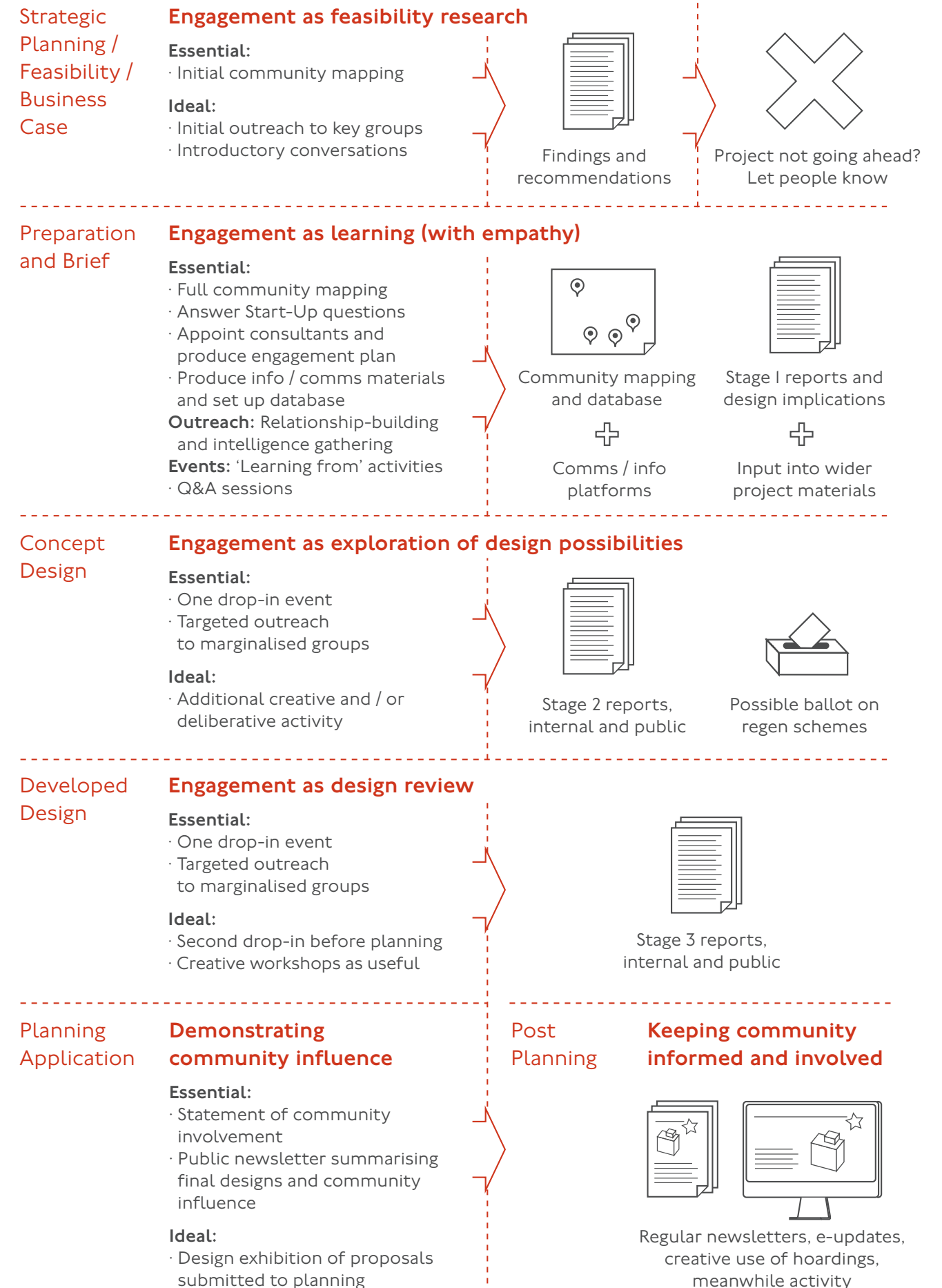

Additional Resources

The London Plan (GLA)
London Housing Design Guide (GLA)
Mayor's Transport Strategy (GLA)
Healthy Streets (Transport for London)
Good Growth by Design (GLA)
Design for a Circular Economy (GLA)
Supporting Diversity Handbook (GLA)
Designing Inclusive Streets (Urban Design London)
The Design Companion for Planning and Placemaking (Urban Design London)
Slow Streets Sourcebook (Urban Design London)
Better Streets Delivered (Urban Design London)
Getting Homes Built (Urban Design London)
A New London Housing Vernacular (Urban Design London)
Public Housing: A London Renaissance (New London Architecture)
Factory Made Housing: A Solution for London (New London Architecture)
London's Towns: Shaping the Polycentric City (New London Architecture)
New Ideas for Housing (New London Architecture)
Overcoming London's Barriers (Future of London)

Contributions by:
Alan Baxter Associates
Arup
Daisy Froud
Design England
Design South East
GLA
Mayoral Design Advocates
Public Practice
Publica

Editor:
Tom Sykes

Theme Illustrations:
Gilbert Leung

Architectural illustrations:
Objectif

Design:
Objectif

© Transport for London, 2020

Theme Illustrations
(pp 10, 16, 22, 30, 36, 42)
© Gilbert Leung, 2020

