

1. CW3 & CW4 Ownership - Pre-Roof Beam Removal

 CAPCO Asset  
 LUL Asset

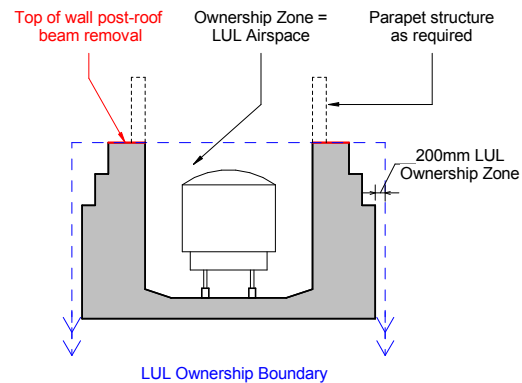

2. CW3 & CW4 Ownership - Post-Roof Beam Removal

Note: All work to ensure the stability of the existing tunnel walls and the removal of the roofs will be completed by CAPCO prior to handover of CW3 and CW4 to LUL.

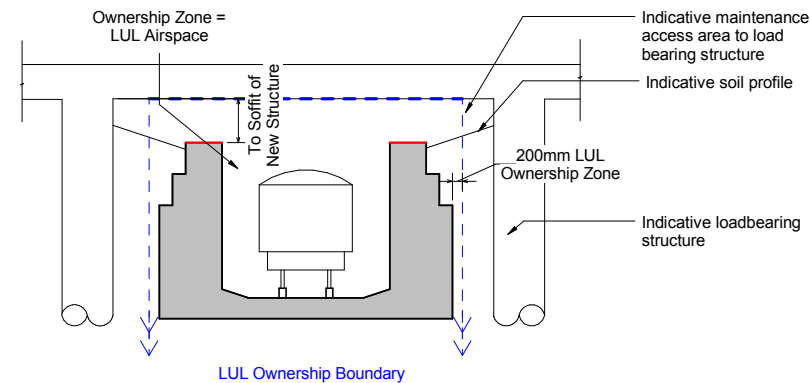

3. CW3 & CW4 Ownership - Post New Construction

Notes:

- The thickness of the existing structure is assumed from historic drawings. Following demolition of EC1 greater certainty of tunnel structure will be established. This could result in a potential breach of the clearance lines outlined in these drawings.
- Any existing non-LUL structure which is within the LUL ownership boundary will be owned by CAPCO. Any modifications required to the existing non-LUL structure which is within the LUL ownership boundary will be subject to LUL critical works approval. Any new structure required to be built within the LUL ownership boundary will be subject to LUL critical works approval.

P3	17/03/14	KB	SRT	TJ
P2	05/03/14	KB	SRT	TJ
P1	28/02/14	KB	SRT	TJ
Issue	Date	By	Chkd	Appd

**ARUP**  
 13 Filzoy Street  
 London W1T 4BQ  
 Tel +44 (0)20 7636 1531 Fax +44 (0)20 7580 3624  
 www.arup.com

Client  
 Capital & Counties Properties PLC

Job Title  
 Project Earls Court

Earls Court and LUL  
 Design Principles  
 Sheet 2 of 2

Scale at A1 NTS

Discipline Structural

Job No 125066

Drawing No ARUP-ST-LAI-019

Issue P3

For Information

Issue