

**RiverLinx CJV**

7th Floor, One Canada Square  
Canary Wharf  
London E14 5AA

**For the Attention of:**

Matthew Lund  
Planning Officer  
Planning & Building Control  
The Royal Borough of Greenwich  
5th Floor  
The Woolwich Centre  
35 Wellington St  
Woolwich  
London SE18 6HQ

Date: 4th May 2020

Our Reference: GRN-CJV-RBG-34 / 41 / 73

Dear Matthew,

**The Silvertown Tunnel Order 2018 ('the Order') application for approval of the detailed design, surface water drainage, and associated landscaping of Work Number 13 (a replacement Gas Pressure Reduction Station and accesses), and for the removal of an existing Gas Pressure Reduction Station (Work Number 2 (k)) – to partially discharge the requirements at Paragraphs 4, 6, and 8 of Schedule 2 of the Order.**

Riverlinx have been awarded the Silvertown Tunnel Project by Transport for London on 21<sup>st</sup> November 2019. The Riverlinx Construction Joint Venture (Riverlinx CJV) – consisting of a joint venture between Ferrovial Agroman UK Ltd, Bam Nuttall Ltd, and SK Engineering and Construction Co. Ltd - will construct the Silvertown Tunnel project. The Riverlinx CJV are empowered to make submissions under the Order by virtue of its Article 59 ('Transfer of Benefit of Order').

This application, submitted under the process outlined within Part 2 of Schedule 2 of the Order, consists a final submission made for the partial discharge of the above stated Order Requirements. Accordingly, the Royal Borough of Greenwich is required to determine the application within 8 weeks (which commences the day after the application is received) which would be no later than 30<sup>th</sup> June 2020.

Thank you for your earlier comments on the draft of this application. These have been taken into account in preparing this final submission.

**The Proposals**

The works subject to this consent application are particularly minor in terms of scale and size.

An existing Gas Pressure Reduction Station (PRS) within the Scottish Gas Networks (SGN) site off Millennium Way will need to be removed as part of the Silvertown Tunnel project (under Work Number 2(k) of Schedule 1 of the Order). The existing PRS location is shown at the bottom of Figure 1 below.

The Order provides development consent for a replacement PRS to be provided on SGN operational land (under Work Number 13 of Schedule 1), which will comprise minor and largely standardised prefabricated infrastructure including a governor structure, associated pipework and a ventilation column. The location for the replacement PRS requires the creation of a new operational access onto Millennium Way, with associated minor works within the highway and footway and the installation of a length of palisade fencing and a gate. This access will be used solely to access the replacement PRS. The location of the site of the replacement PRS and its access is shown on Figure 1 below.

In addition, as a result of the future alignment of the Silvertown Tunnel project, the SGN gasholder site will require a new main operational access from Millennium Way (also to be provided under Work Number 13 of Schedule 1 of the Order). The location of this proposed Gasholder Access is shown on Figure 1 below.

**Figure 1 – Areas Referred to in this Application (not to scale – for information only)**



These two proposed accesses are specified within the Order's Rights and Way Access Plan, Sheet 1 annotated as (2) and (6). These two accesses are detailed within Schedule 3, Part 3 of the Order (extract below):

<b>(1) Area</b>	<b>(2) Private means of access to be stopped up</b>	<b>(3) Extent of stopping up</b>	<b>(4) New private means of access to be substituted/provided</b>
In the administrative area of the Royal Borough of Greenwich; in the county of Greater London	Reference a Access to premises (occupied by Priority TM Limited and Southern Gas Networks plc) on the south side of the existing Millennium Way, 50 metres southeast of its junction with the existing Edmund Halley Way.	A length from its junction with the existing Millennium Way south-eastward, for a distance of 20 metres.	Reference 2 To be substituted by a new private means of access located to the east of the new Silvertown Tunnel, providing access from the south side of the existing Millennium Way.
	-	-	Reference 6 New private means of access located on the east side of the Silvertown tunnel, providing access from the south side of the existing Millennium Way, to new pressure reduction station (PRS).

A legal agreement is in place between TfL and SGN relating to the works taking place on SGN owned land and affecting SGN interests, and Riverlinx CJV have been appointed as agents to TfL for the execution of that legal agreement. SGN have been heavily involved throughout the design process recognising that the infrastructure proposed will become their assets.

### **Programme**

The provision of the replacement PRS and the associated access is an important and programme critical enabling works for the Silvertown Tunnel project and will be commenced as soon as the necessary consents are secured.

The new Gasholder Access onto Millennium Way will be constructed later in the programme but is included in this application for completeness.

**The Order Requirements**

This application seeks to partially discharge the requirements at Paragraphs 4, 6, and 8 of Schedule 2 of the Order (hereafter referred to as Requirements 4, 6 and 8)

Requirement 4 states:

**“Detailed design of above ground buildings and structures**

4.—(1) Construction of each part of the authorised development specified in column (1) of the table below must not commence until the details of the elements specified in relation to that part in column (2) of that table have been submitted to and approved in writing by the relevant planning authority. *(table truncated for clarity)*

<b>(1) Part of the authorised development</b>	<b>(2) Elements to be approved</b>
Work No. 13	Siting, design and external appearance

(2) The authorised development must be carried out in accordance with details approved by the relevant planning authority under sub-paragraph (1).”

Requirement 6 states:

**“Landscaping scheme**

6.—(1) No part of the authorised development may commence until a written landscaping scheme for that part has been submitted to and approved in writing by the relevant planning authority.

(2) A landscaping scheme prepared under sub-paragraph (1) must be in accordance with the landscaping plan and include details of hard and soft landscaping works, including—

(a) location, number, species, size and planting density of any proposed planting, including habitat creation in lieu of offsite biodiversity offsetting;

(b) cultivation, importing of materials and other operations to ensure plant establishment;

(c) the location and specification of routes for non-motorised users including provision of a bus stop to serve southbound buses in the re-aligned Tunnel avenue;

(d) proposed finished ground levels;

(e) hard surfacing materials;

(f) details of existing trees to be retained, with measures for their protection during the construction period; and

(g) implementation timetables for all landscaping works.

(3) Each part of the authorised development must be carried out in accordance with the relevant landscaping schemes approved under sub-paragraph (1).

(4) All landscaping works must be carried out to a reasonable standard in accordance with the relevant recommendations of appropriate British Standards or other recognised codes of good practice.

(5) Any tree or shrub planted as part of a landscaping scheme that, within a period of 5 years after planting, is removed, dies or becomes, in the opinion of the relevant planning authority,

seriously damaged or diseased, must be replaced in the first available planting season with a specimen of the same species and size as that originally planted”.

Requirement 8 states:

**“Surface water drainage details**

8.—(1) No part of the authorised development which comprises any part of a surface water drainage system must commence until written details of that surface water drainage system have been submitted to and approved by the relevant planning authority.

(2) The surface water drainage system for the relevant part of the authorised development must be constructed in accordance with the details approved under sub-paragraph (1).”

**The Scope of this Application**

This application seeks to partially discharge Requirements 4, 6, and 8 in respect of the works described above.

The existing PRS equipment will be carefully dismantled and removed by SGN. The foundations of the equipment will be left in situ and the surface reinstated to match the immediate vicinity.

The application seeks to discharge the Requirement 4 in respect of the siting, design, and external appearance of the replacement Gas Pressure Reduction Station and its immediate access (the access to the north east of the existing gas holder). The siting, design, and approval of the Gasholder Access (the access to the north west of the existing gas holder) does not fall under this requirement, and is therefore outside of the scope of this application.

The siting of the infrastructure proposed is guided by operational requirements.

The design and external appearance of the infrastructure proposed is also a product of its operational purpose and standard industry specification. The replacement Gas Pressure Reduction Station being delivered under the Order consists largely of underground pipework, with the only exceptions being the provision of a governor structure and a ventilation column which are within the operational compound. For context, the governor is a pre-fabricated utility structure rather than a building and it is subject to a standard industry specification that does not allow for the installation of photovoltaic panels or a green roof on top.

Requirement 6 obligates the landscaping proposals to accord with the Landscaping Plan submitted alongside the Order<sup>1</sup>. Whilst it is identified that the Order’s Landscaping Scheme did not specify any landscaping at the locations subject to the scope of this application, Riverlinx CJV is seeking approval for the external visual appearance of the finished works. It is nonetheless noted that the Order permits there to be no landscaping works required at the location of the Gas Pressure Reduction Station and its accesses.

---

<sup>1</sup> <https://infrastructure.planninginspectorate.gov.uk/wp-content/ipc/uploads/projects/TR010021/TR010021-001653-TFL%208.88%20Landscaping%20Plan%20R1.pdf>



Therefore we can clarify that, in relation to Requirement 6 (2) (a) and (b), no planting is proposed for these works (aside from reinstatement of highway verges where disturbed), being as the proposals fall within an operational Scottish Gas Networks compound with no public access.

This application does not seek to discharge Requirement 6 (2) (c) as it is not relevant to this application.

In respect to Requirement 6 (2) (f), it is confirmed that there will be no retained trees within the scope of these works that will require protection.

Fencing details are included in the drawing pack. As requested in the comments received on the draft application we have included an elevation of the proposed fencing and how this would appear from Millennium Way. It is an operational requirement for the new section of fencing to be taller than existing, to ensure site security for the new PRS. This accounts for the new section of fencing being slightly taller than the existing fencing on either side. The colour and style of the new fencing will match that of the existing to ensure visual continuity.

In relation to Requirement 8 (Surface Water Drainage), details are provided for the access intended for the new accesses. It is to be noted that the remainder of the SGN compound, including the location of the replacement Gas Pressure Reduction Station will comprise a permeable naturally draining surface.

It is to be noted that highways considerations fall outside of the scope of this application. These are subject to separate approval within applications to be made to the relevant street authority (RB Greenwich) under Article 11 of the Order. Nonetheless, as requested in the comments received on the draft application, we have included vehicle swept path drawings in the application for information to demonstrate that vehicles can enter and leave the sites safely by turning within the operational site.

The following drawings are submitted alongside this application bound within document number ST150030-RLC-ZZZ-06-S10-PEM-TP-0001 (Rev P03), and together with this covering letter, comprise the formal application submitted for approval:

Drawing Title	Drawing Number	Information shown on Drawing re. DCO Sch2 Requirement	For Approval/For Information
Site Location/Context	ST150030-ARC-MAC-06-ZY-SKE -HE-0011	Location context	For Information Only
New Access 1 - Plan and Profile	ST150030-ARC-MAC-06-S10-SKE-HE-0001	Requirements 4 and 6	For Approval
New Access 2 - Plan and Profile	ST150030-ARC-MAC-06-S10-SKE-HE-0002	Requirements 4 and 6	For Approval
Drainage Details and Schedule	ST150030-ARC-DRG-06-S10-SKE-DR-0001	Requirement 8	For Approval
Kerbs, Footways and Paved Areas	ST150030-ARC-COR-06-S10-SKE-HE-0001	Requirements 4 and 6	For Approval

Lighting, Fencing and Barriers	ST150030-ARC-MAC-06-S10-SKE-HE-0003	Requirements 4 and 6	For Approval
Site Clearance and Utilities	ST150030-ARC-MAC-06-S10-SKE-HE-0004	Requirements 4 and 6	For Approval
Visibility Splay Verification	ST150030-ARC-MAC-06-S10-SKE-HE-0005	Design context only	For Information Only
Gas Holder Access Vehicular Swept Path	ST150030-ARC-MAC-06-S10-SKE-HE-0010	Design context only	For Information Only
SGN PRS Access Swept Path	ST150030-ARC-MAC-06-S10-SKE-HE-0007	Design context only	For Information Only
Vegetation Layout	ST150030-ARC-MAC-06-S10-SKE-HE-0008	Requirements 4 and 6	For Approval
SGN PRS Access Elevation	ST150030-ARC-MAC-06-S10-SKE-HE-0009	Requirements 4 and 6	For Approval
Governor Replacement – Civil Site Layout	ST150030-RLC-MAC-06-S10-SKE-HE-0001	Requirements 4 and 6	For Approval
Governor Replacement Skid Foundation	ST150030-RLC-MAC-06-S10-SKE-HE-0002	Requirements 4 and 6	For Approval
Governor Replacement - Vent Stack Foundation	ST150030-RLC-MAC-06-S10-SKE-HE-0003	Requirements 4 and 6	For Approval
Governor Replacement - Internal Roads Details	ST150030-RLC-MAC-06-S10-SKE-HE-0004	Requirements 4 and 6	For Approval
Governor Replacement Fencing Details	ST150030-RLC-MAC-06-S10-SKE-HE-0005	Requirements 4 and 6	For Approval
Governor Replacement - Inlet Stopple Details	ST150030-RLC-MAC-06-S10-SKE-HE-0006	Requirements 4 and 6	For Approval
Replacement Gas PRS - New Gas Governor Inlet Pipework Details	ST150030-RLC-MAC-06-S10-SKE-HE-0007	Requirements 4 and 6	For Approval
Governor Replacement - Outlet Stopple Details	ST150030-RLC-MAC-06-S10-SKE-HE-0008	Requirements 4 and 6	For Approval
Governor Replacement - Outlet Pipework Detail	ST150030-RLC-MAC-06-S10-SKE-HE-0009	Requirements 4 and 6	For Approval

If you have any queries relating to this submission please don't hesitate to contact me on –

[Redacted]

Yours Sincerely,

[Redacted Signature]

Tim Snell

Planning Consents Lead, Riverlinx CJV

[Redacted]



**DOCUMENT TITLE:**

**Pressure Reduction Station (PRS) Works and  
Accesses - Drawings Accompanying Consents  
Submission**

**DOCUMENT NUMBER:**

**ST150030-RLC-ZZZ-06-S10-PEM-TP-0001**

<b>PURPOSE OF ISSUE</b>	For Acceptance	<b>DOCUMENT SUITABILITY</b>	S3 - For Review & Comment	<b>TOTAL PAGES (Including this page)</b>	23
-------------------------	----------------	-----------------------------	---------------------------	--	----

Prepared by	Checked by	Approved by	Date	Revision
			04/05/2020	P03

UNCONTROLLED WHEN PRINTED

ST150030-RLC-ZZZ-06-S10-PEM-TP-0001

Revision P03

04/05/2020



**Issue and Revision Control**

Document uncontrolled when printed.

<b>Revision History</b>			
<b>Rev No</b>	<b>Date</b>	<b>Summary of Changes</b>	<b>Section &amp; Number</b>
P01	10/03/2020	First Issue	-
P02	17/04/2020	Final Draft Submission	-
P03	04/05/2020	Final Application to RBG	-

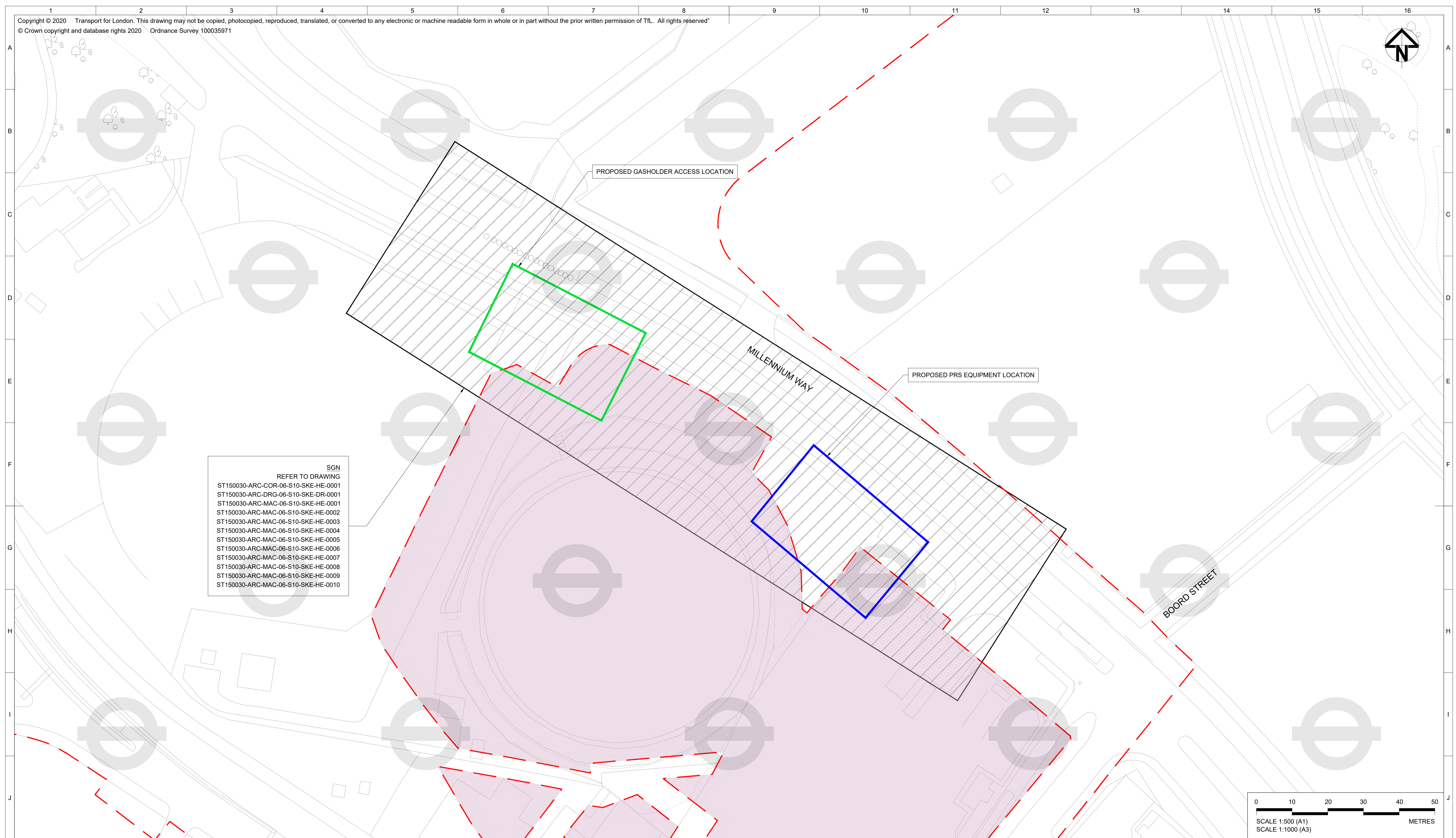
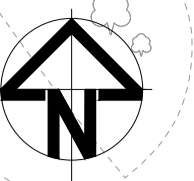

SGN
REFER TO DRAWING
ST150030-ARC-COR-06-S10-SKE-HE-0001
ST150030-ARC-DRG-06-S10-SKE-DR-0001
ST150030-ARC-MAC-06-S10-SKE-HE-0001
ST150030-ARC-MAC-06-S10-SKE-HE-0002
ST150030-ARC-MAC-06-S10-SKE-HE-0003
ST150030-ARC-MAC-06-S10-SKE-HE-0004
ST150030-ARC-MAC-06-S10-SKE-HE-0005
ST150030-ARC-MAC-06-S10-SKE-HE-0006
ST150030-ARC-MAC-06-S10-SKE-HE-0007
ST150030-ARC-MAC-06-S10-SKE-HE-0008
ST150030-ARC-MAC-06-S10-SKE-HE-0009
ST150030-ARC-MAC-06-S10-SKE-HE-0010

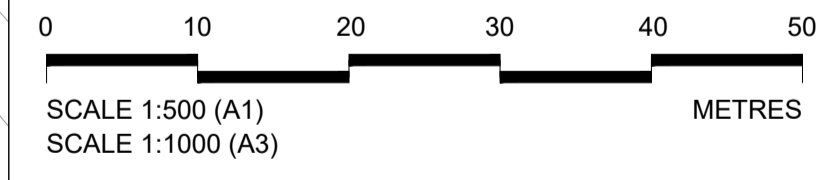

**LEGEND:**

- ORDER LIMITS
- PROPOSED PRS EQUIPMENT LOCATION
- AREA EXCLUDED FROM ORDER LIMITS
- PROPOSED GASHOLDER ACCESS LOCATION
- VIEWFRAME
- EXISTING FEATURES

Rev	Date	Purpose / Description	T. Checked	T. Approved	P. Approved	Authorised
P02	04/05/20	SP SH				
P01	09/04/20	SP SH				

Project	Silvertown Tunnel
Originator	Arcadis
Location	Greenwich
Asset Classification	Multiple Asset Classification
Lifecycle	Detailed Design
Suitability	S2
Fit for Information	Fit for Information

Title	
Drawing Supporting SGN PRS Consent Submission	
Location Plan	
Drawing Number	Rev.
ST150030-ARC-MAC-06-ZY-SKE -HE-0011	P02



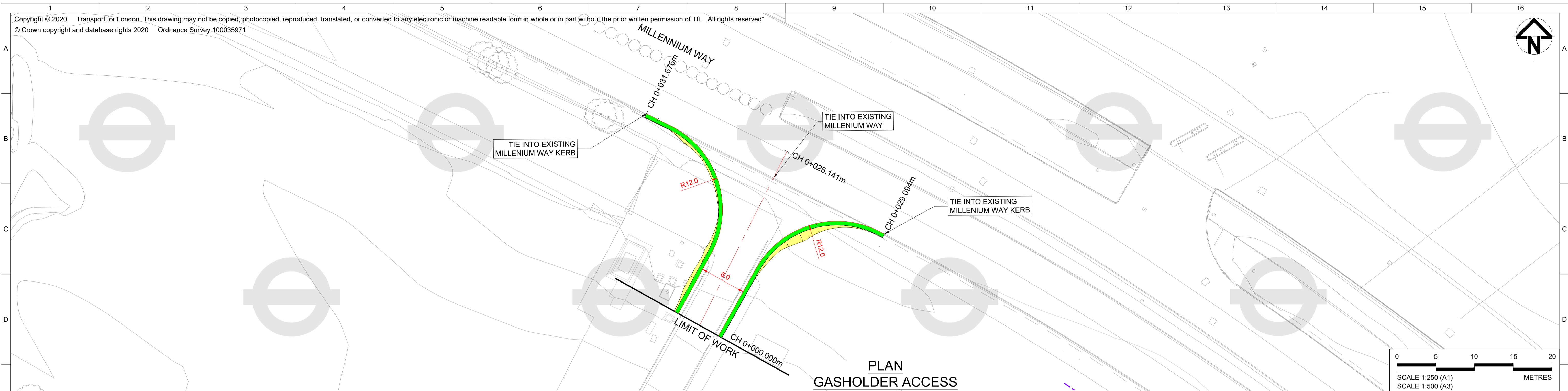
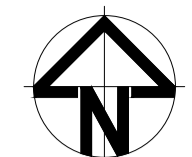

PLAN  
GASHOLDER ACCESS

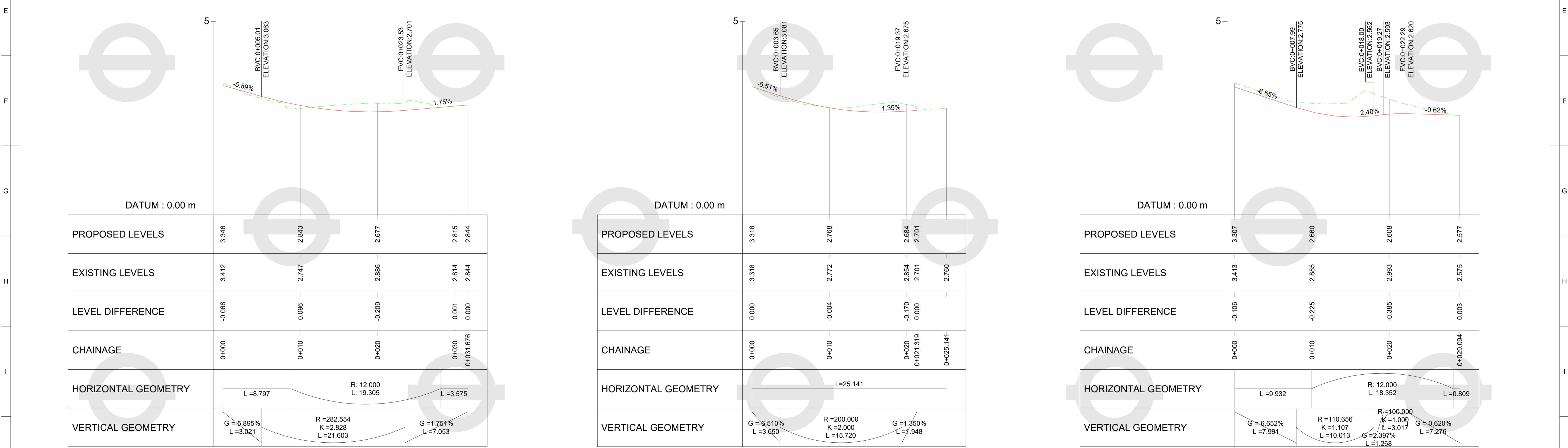
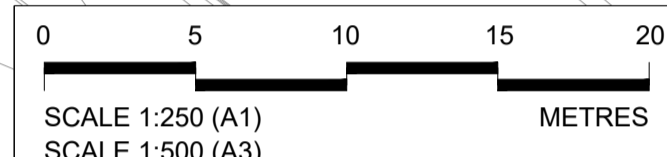

LONGITUDINAL SECTION GASHOLDER ACCESS LEFT KERB  
SCALE: 1:250 (H) 1:50 (V)

LONGITUDINAL SECTION GASHOLDER ACCESS  
SCALE: 1:250 (H) 1:50 (V)

LONGITUDINAL SECTION GASHOLDER ACCESS RIGHT KERB  
SCALE: 1:250 (H) 1:50 (V)

**LEGEND:**

	ROAD CENTRE LINE		PROPOSED LEVELS
	PROPOSED VERGE		EXISTING LEVELS
	PROPOSED EARTHWORK		

Restricted	Project	Silvertown Tunnel	Title	Drawing Supporting SGN PRS Consent Submission
	Originator	Arcadis	Location	Plan and Profile 1
	Greenwich	Asset Classification	Multiple Asset Classification	
	Asset Classification	Multiple Asset Classification	Lifecycle	
	Location	Greenwich	Detailed Design	
	Originator	Arcadis	Suitability	
	Project	Silvertown Tunnel	Drawing Number	ST150030-ARC-MAC-06-S10-SKE-HE-0001
	Originator	Arcadis	Rev.	P02
	Greenwich	Asset Classification		
	Asset Classification	Multiple Asset Classification		



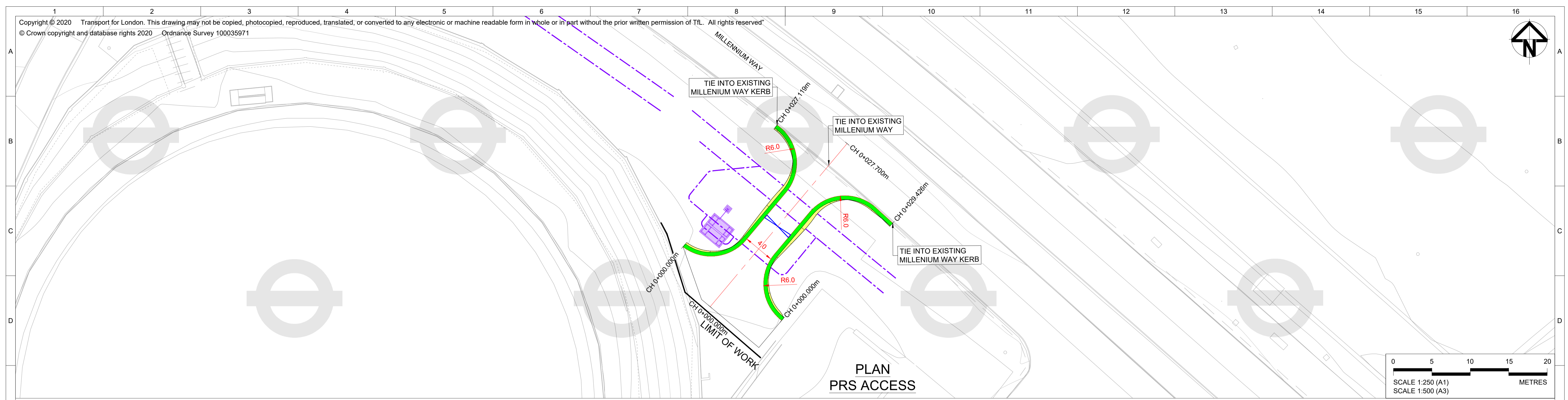
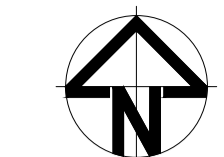

PLAN  
PRS ACCESS

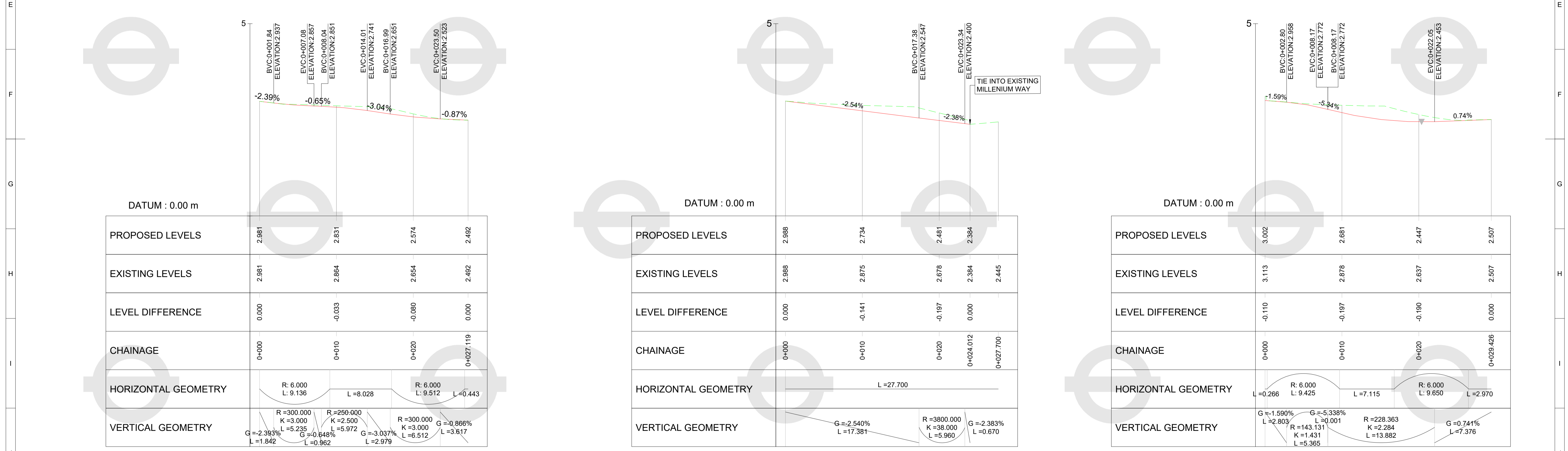
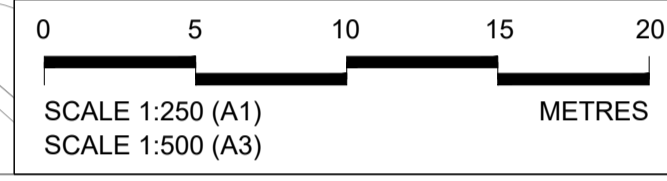

LONGITUDINAL SECTION PRS ACCESS LEFT KERB  
SCALE: 1:250 (H) 1:50 (V)

LONGITUDINAL SECTION PRS ACCESS  
SCALE: 1:250 (H) 1:50 (V)

LONGITUDINAL SECTION PRS ACCESS RIGHT KERB  
SCALE: 1:250 (H) 1:50 (V)

- LEGEND:**
- PLAN:**
- ROAD CENTRE LINE
  - GAS MAIN
  - PROPOSED VERGE
  - PROPOSED EARTHWORK
- PROFILE:**
- PROPOSED LEVELS
  - EXISTING LEVELS

Restricted	Project	Silvertown Tunnel	Title	Drawing Supporting SGN PRS Consent Submission	
	Originator	Arcadis	Location	Plan and Profile 2	
	Asset Classification	Greenwich	Multiple Asset Classification		
	Lifecycle	Multiple Asset Classification			
	Detailed Design	Greenwich	Detailed Design		
	Suitability	Asset Classification	Suitability		
	Drawn	T. Checked	T. Approved	P. Approved	Authorised
	Date				
	Rev				



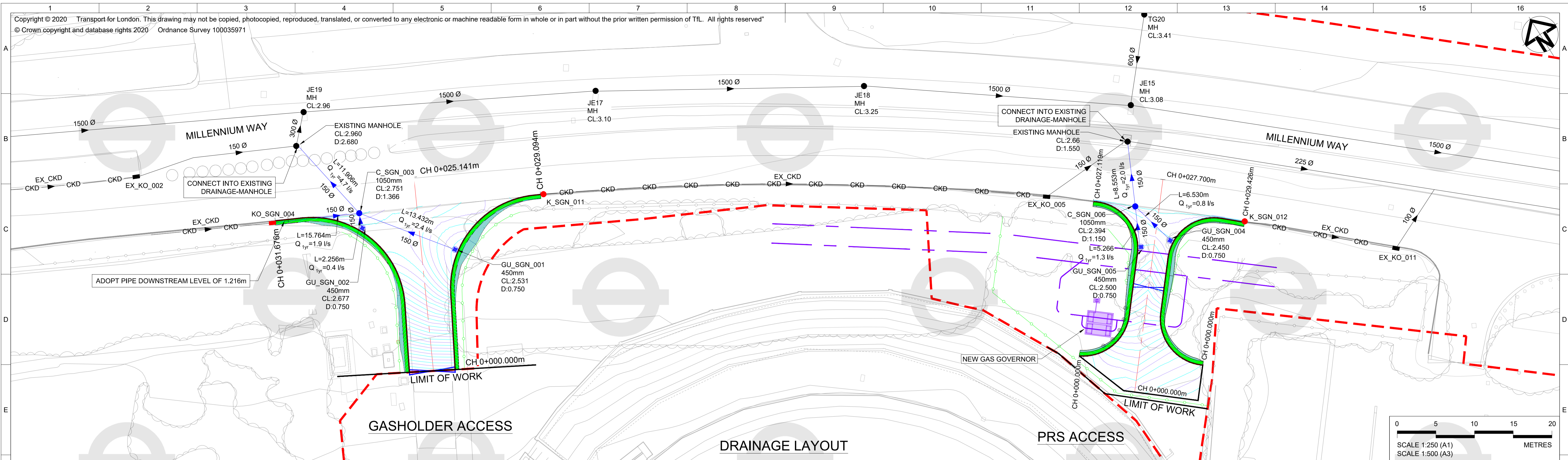

**PROPOSED PIPE AND CHAMBER SCHEDULE**

Location	Chamber Details										Pipe Out				Pipe In				Pipe Out Details			Comments
	Chainage	Easting	Northing	Loading Class	Chamber Cover Type	Chamber Cover Opening Size	Chamber Type	Cover Level	Cover Clear Opening	Chamber Size	Invert Level	Diameter	Slope	Depth to Invert	Invert Level	Diameter	Slope	Depth to Invert	Length	Type	Material	
Verge	N/A	539254.074	179459.047	D400	Solid	600 x 600	7	2.751	600 x 600 (S)	1050	1.385	150	304.0	1.366	1.385	150	4.2	1.366	11.906	PR Carrier	Thermoplastic	This Proposed Catchpit is for SGN Access 1. Gully Pipe is outfalling into Proposed Catchpit.
Verge	N/A	539243.931	179464.005	N/A	Solid	N/A	N/A	2.961	N/A	N/A	N/A	N/A	N/A	N/A	N/A	N/A	N/A	N/A	N/A	N/A	N/A	Kerb Outlet Pipe is discharging into Proposed Catchpit.
Verge	N/A	539275.489	179448.339	N/A	Solid	N/A	N/A	2.574	N/A	N/A	N/A	N/A	N/A	N/A	N/A	N/A	N/A	N/A	N/A	N/A	N/A	Proposed Kerb Outlet for Existing CKD
Verge	N/A	539396.106	179396.730	N/A	Solid	N/A	N/A	2.485	N/A	N/A	N/A	N/A	N/A	N/A	N/A	N/A	N/A	N/A	N/A	N/A	N/A	Proposed Kerb Access Unit for Existing CKD
Verge	N/A	539339.198	179405.953	D400	Solid	600 x 600	7	2.394	600 x 600 (S)	1050	1.244	150	145.0	1.150	1.244	150	10.4	1.150	8.553	PR Carrier	Thermoplastic	This Proposed Catchpit is for SGN Access 2. Gully Pipe is outfalling into Proposed Catchpit.

**PROPOSED GULLY SCHEDULE**

Reference	Chainage	Chamber Co-Ordinates		Cover Class (BS EN 124)	Pipe Out Details				Comments
		Easting	Northings		Length	Diameter	Type	Material	
GU_SGN_001	CH 0+015	539262.119	179448.291	D400	13.432	150	PR Carrier Drain	Thermoplastic	This Gully is for SGN Access 1.
GU_SGN_002	CH 0+019	539253.306	179456.925	D400	2.256	150	PR Carrier Drain	Thermoplastic	This Gully is for SGN Access 1.
GU_SGN_004	CH 0+020	539340.743	179399.608	D400	6.530	150	PR Carrier Drain	Thermoplastic	This Gully is for SGN Access 2.
GU_SGN_005	CH 0+023	539399.608	179401.213	D400	5.266	150	PR Carrier Drain	Thermoplastic	This Gully is for SGN Access 2.

- NOTES:**
- ALL DRAWINGS MUST BE READ IN CONJUNCTION WITH NOTES ON DRAWING No. ST150030-ARC-MAC-06-ZY-SKE-HE-0011.
  - ALL DIMENSIONS ARE IN METRES UNLESS OTHERWISE STATED.
  - THIS DRAWING SHOULD BE READ IN CONJUNCTION WITH ALL OTHER RELEVANT ENGINEERING DETAIL DRAWINGS AND SPECIFICATIONS.
  - ANY DISCREPANCIES SHOULD BE REPORTED TO THE ENGINEER IMMEDIATELY SO THAT CLARIFICATIONS CAN BE SOUGHT PRIOR TO THE COMMENCEMENT OF WORK.
  - AFFECTED VERGES TO BE MADE GOOD AS PER THE LOCAL AUTHORITY REQUIREMENTS.
  - ALL CONSTRUCTION SHOULD BE IN ACCORDANCE WITH THE SPECIFICATION FOR HIGHWAY WORKS VOLUME 1.

**LEGEND:**

- ORDER LIMITS
- EXISTING FEATURES
- PROPOSED KERB
- PROPOSED MAJOR CONTOUR
- PROPOSED MINOR CONTOUR
- GAS MAIN
- 1500 Ø EXISTING PIPE
- 150 Ø PROPOSED CARRIER DRAIN
- PROPOSED ALIGNMENT
- EX\_CKD EXISTING COMBINED KERB DRAINAGE
- CKD CKD
- EX\_GU\_XXX EXISTING GULLY WITH REF NUMBER
- GU\_SGN\_XXX PROPOSED GULLY WITH REF NUMBER
- EX\_KO\_XXX EXISTING CKD OUTFALL CHAMBER WITH REFERENCE NUMBER
- X\_SGN\_XXX PROPOSED MANHOLE / CATCHPIT WITH REFERENCE NUMBER
- K\_SGN\_XXX PROPOSED CKD ACCESS CHAMBER WITH REFERENCE NUMBER
- KO\_SGN\_XXX PROPOSED CKD OUTFALL CHAMBER WITH REFERENCE NUMBER
- JE XX EXISTING MANHOLE / CATCHPIT WITH REF NUMBER
- EXISTING TREE CANOPY

**Restricted**

Rev	Date	Purpose / Description	T. Checked	T. Approved	P. Approved	Authorised
P02	17/06/20	GG SH				
P01	09/04/20	SP SH				

Project	Silvertown Tunnel	Title	Drawing Supporting SGN PRS Consent Submission
Originator	Arcadis	Location	Greenwich
Asset Classification	Drainage	Lifecycle	Detailed Design
Suitability	S2	Fit for Information	
Drawing Number	ST150030-ARC-DRG-06-S10-SKE-DR-0001	Rev.	P02



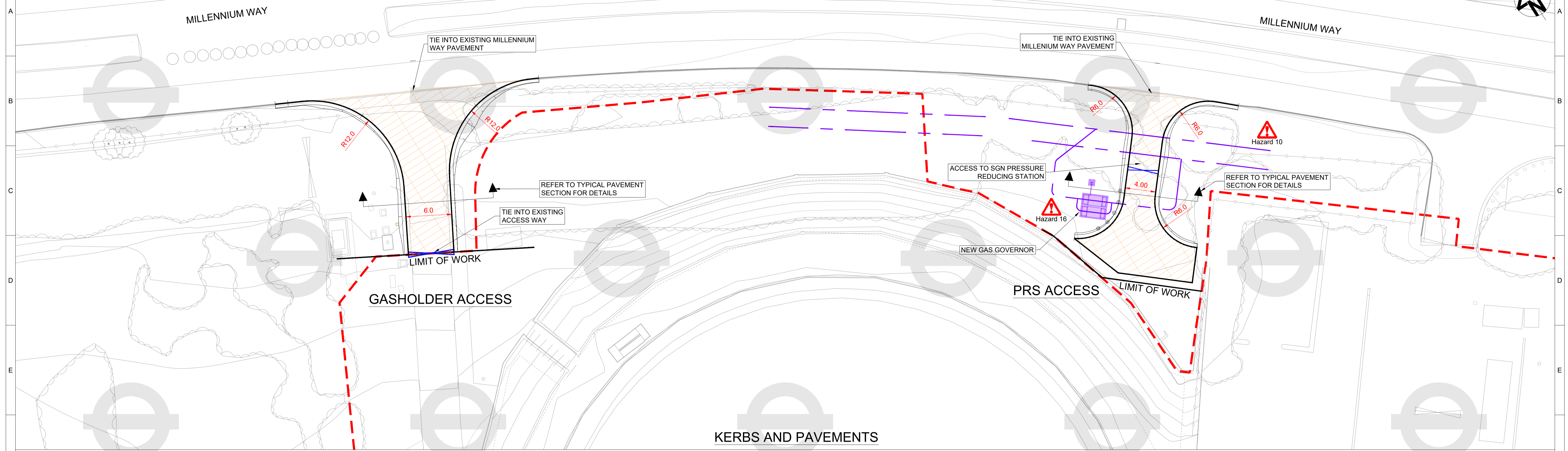

**KERBS AND PAVEMENTS**

**TYPICAL PAVEMENT SECTION  
PAVEMENT TYPE A1**  
SCALE 1:10

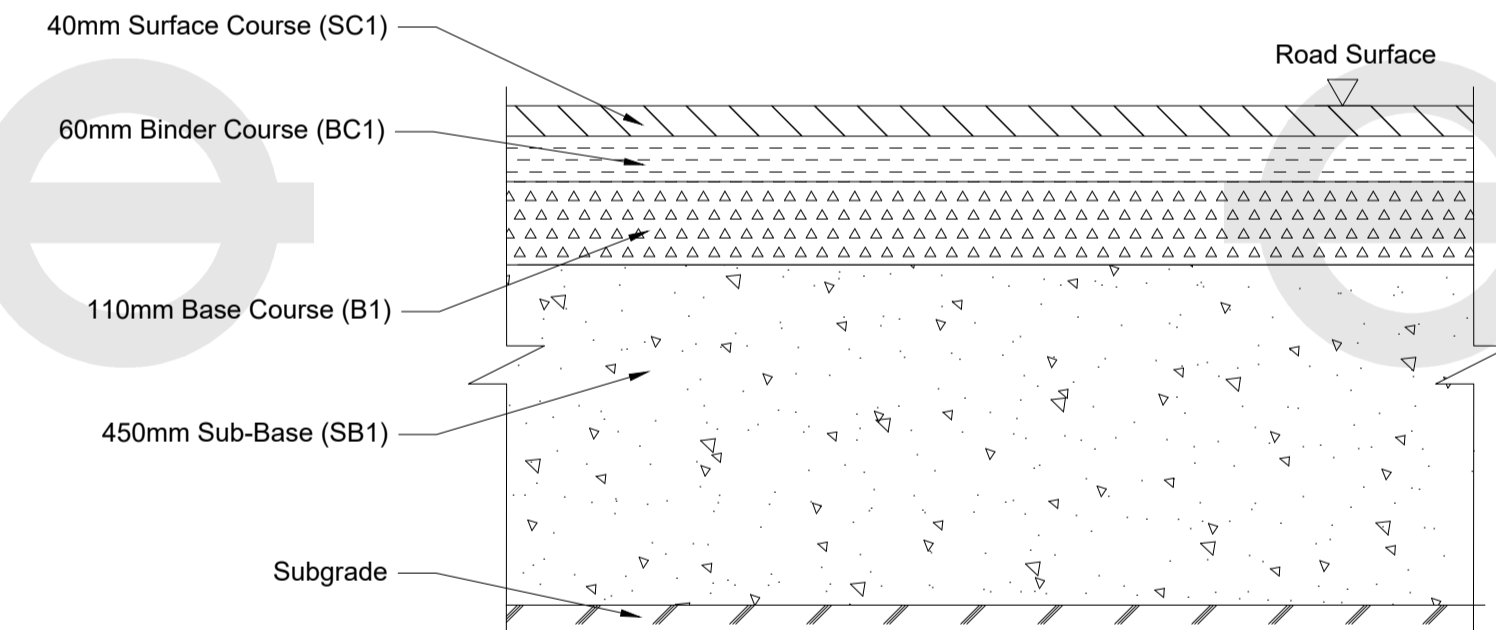
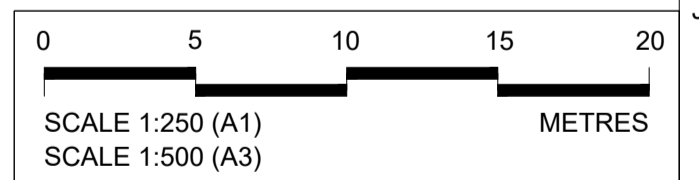

Table 1: Pavement Design for Entrances.

Pavement Type: A1 (Traffic 1.5 MSA)			
Layers	Thickness in mm	Designation	Material
Surface Course	40	AC	AC10 close surf 70/100, Clause 912, PSV 60
Binder Course	60	AC	AC20 Dense bin 40/60, Clause 906
Base Course	110	AC	AC32 Dense base 40/60, Clause 906
Sub Base	450	Type 1	Clause 803
<b>Total</b>	<b>660</b>		



**LEGEND:**

- - - ORDER LIMITS
- EXISTING FEATURES
- PROPOSED KERB
- GAS MAIN
- EXISTING TREE CANOPY
- PROPOSED CARRIAGEWAY PAVEMENT
- SURFACE COURSE (SC1)
- BASE COURSE (B1)
- SUB-BASE (SCB1)
- BINDER COURSE (BC1)

<b>Restricted</b>	Project Silvertown Tunnel	Title Drawing Supporting SGN PRS Consent Submission
	Originator Arcadis	Kerbs, Footways and Paved Areas
	Location Greenwich	
	Asset Classification Road Pavement Surface Corridor	
	Lifecycle Detailed Design	
	Suitability S2	Drawing Number ST150030-ARC-COR-06-S10-SKE-HE-0001
	Fit for Information	Rev. P01



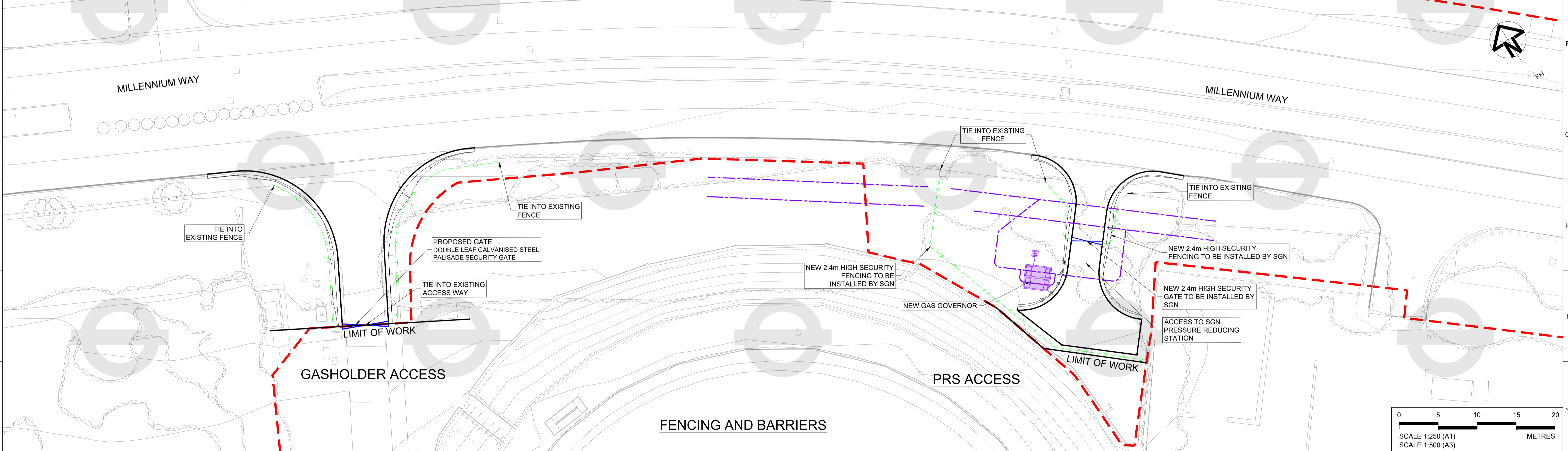
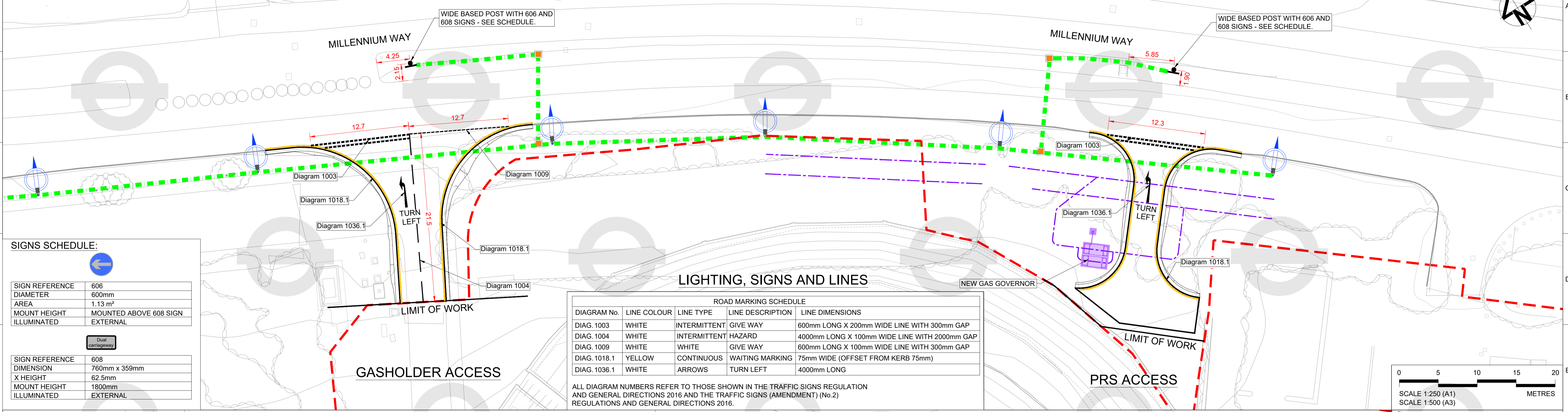

**LEGEND:**

- ORDER LIMITS
- EXISTING FEATURES
- PROPOSED KERB
- PROPOSED FENCE
- EXISTING FENCE
- PROPOSED GATE
- SUGGESTED LIGHTING COLUMN (REFER TO NOTES)
- 1x100mm ID STREET LIGHTING DUCTS  
MIN COVER BELOW CARRIAGEWAY 750mm  
MIN COVER BELOW FOOTWAY 500mm
- EXISTING TREE CANOPY
- GAS MAIN
- BOLLARD TO BE INSTALLED BY SGN
- PROPOSED NAL STAKKA BOX CHAMBER 600mm/600mm/1000mm W/L/D WITH COVER AND FRAME.
- PROPOSED WIDE BASED POST IN CONCRETE FOUNDATION WITH 606 AND 608 SIGNS

**Project**  
 Silvertown Tunnel

**Originator**  
 Arcadis

**Location**  
 Greenwich

**Asset Classification**  
 Multiple Asset Classification

**Lifecycle**  
 Detailed Design

**Suitability**  
 S2

**Title**  
 Drawing Supporting SGN PRS Consent Submission  
 Lighting, Fencing and Barriers

**Drawing Number**  
 ST150030-ARC-MAC-06-S10-SKE-HE-0003

**Rev.**  
 P03



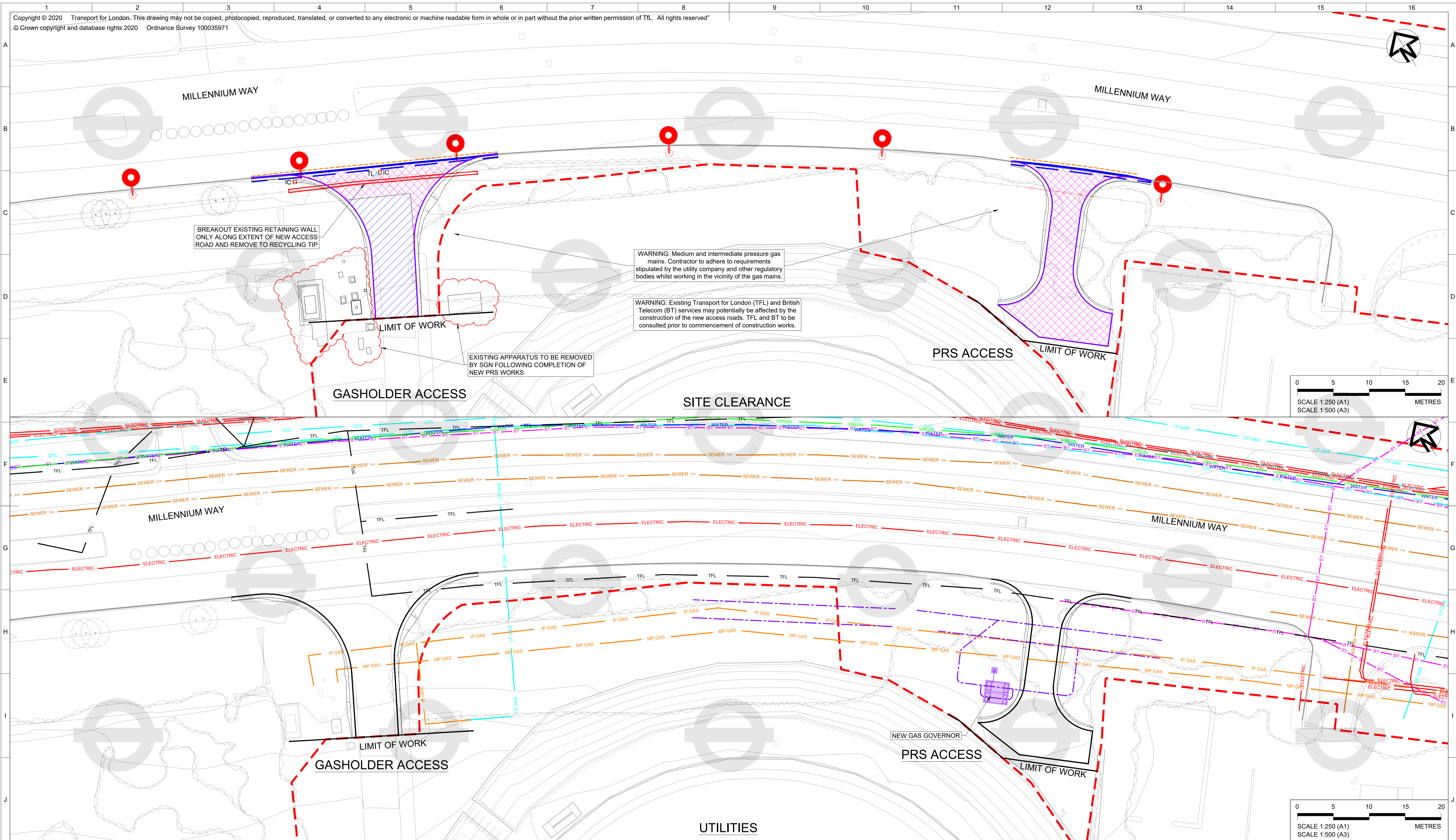

BREAKOUT EXISTING RETAINING WALL ONLY ALONG EXTENT OF NEW ACCESS ROAD AND REMOVE TO RECYCLING TIP

WARNING: Medium and intermediate pressure gas mains. Contractor to adhere to requirements stipulated by the utility company and other regulatory bodies whilst working in the vicinity of the gas mains.

WARNING: Existing Transport for London (TfL) and British Telecom (BT) services may potentially be affected by the construction of the new access roads. TfL and BT to be consulted prior to commencement of construction works.

EXISTING APPARATUS TO BE REMOVED BY SGN FOLLOWING COMPLETION OF NEW PRS WORKS

GASHOLDER ACCESS

SITE CLEARANCE

PRS ACCESS

LIMIT OF WORK

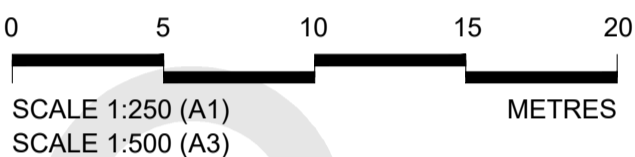

MILLENNIUM WAY

MILLENNIUM WAY

GASHOLDER ACCESS

PRS ACCESS

LIMIT OF WORK

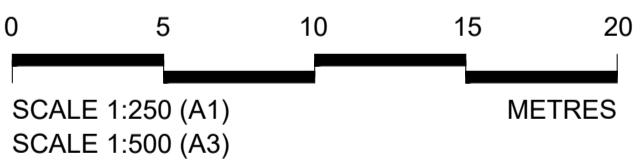

UTILITIES

**LEGEND:**

- ORDER LIMITS
- EXISTING FEATURES
- EXCAVATION FOR NEW KERBS
- EXISTING FENCE TO BE REMOVED TO RECYCLING CENTRE
- EXISTING HOOP BARRIERS TO BE REMOVED TO RECYCLING CENTRE. CONCRETE BASES TO BE EXCAVATED
- LP MAINS
- IP MAINS
- MP MAINS
- ELECTRIC LINE
- SEWER LINE
- TFL --- TFL LINE
- BT
- GTC
- VIRGIN
- WATER MAIN
- GAS MAIN
- PROPOSED KERB
- EXISTING ROAD MARKINGS TO BE REMOVED
- TAKE UP AND REMOVE TO RECYCLING CENTRE EXISTING COMBINED KERB DRAINAGE UNITS
- EXISTING TREE CANOPY
- IC □ INSPECTION COVER TO BE RAISED OR LOWERED TO SUIT NEW LEVELS
- LIGHTING COLUMN TO BE REMOVED AND SET ASIDE FOR RE-USE
- EXISTING GROUND TO BE EXCAVATED TO A DEPTH OF 660mm.(GREATER WHERE REQUIRED)
- EXISTING EARTH/VERGE TO BE REMOVED. GROUND TO BE EXCAVATED TO A DEPTH OF 660mm.(GREATER WHERE REQUIRED)
- TL □ TRAFFIC LIGHT TO BE REMOVED BY OTHERS

Restricted

Rev	Date	Purpose / Description	T. Checked	T. Approved	P. Approved	Authorised
P01	09/04/20	SP	SH	---	---	---

Project	Silvertown Tunnel
Originator	Arcadis
Location	Greenwich
Asset Classification	Multiple Asset Classification
Lifecycle	Detailed Design
Suitability	S2
Fit for Information	Fit for Information

Title		Drawing Supporting SGN PRS Consent Submission	
Site Clearance and Utilities			
Drawing Number		ST150030-ARC-MAC-06-S10-SKE-HE-0004	
Rev.		P01	



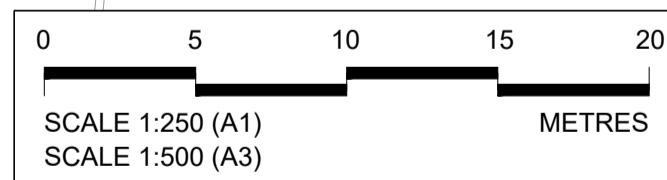
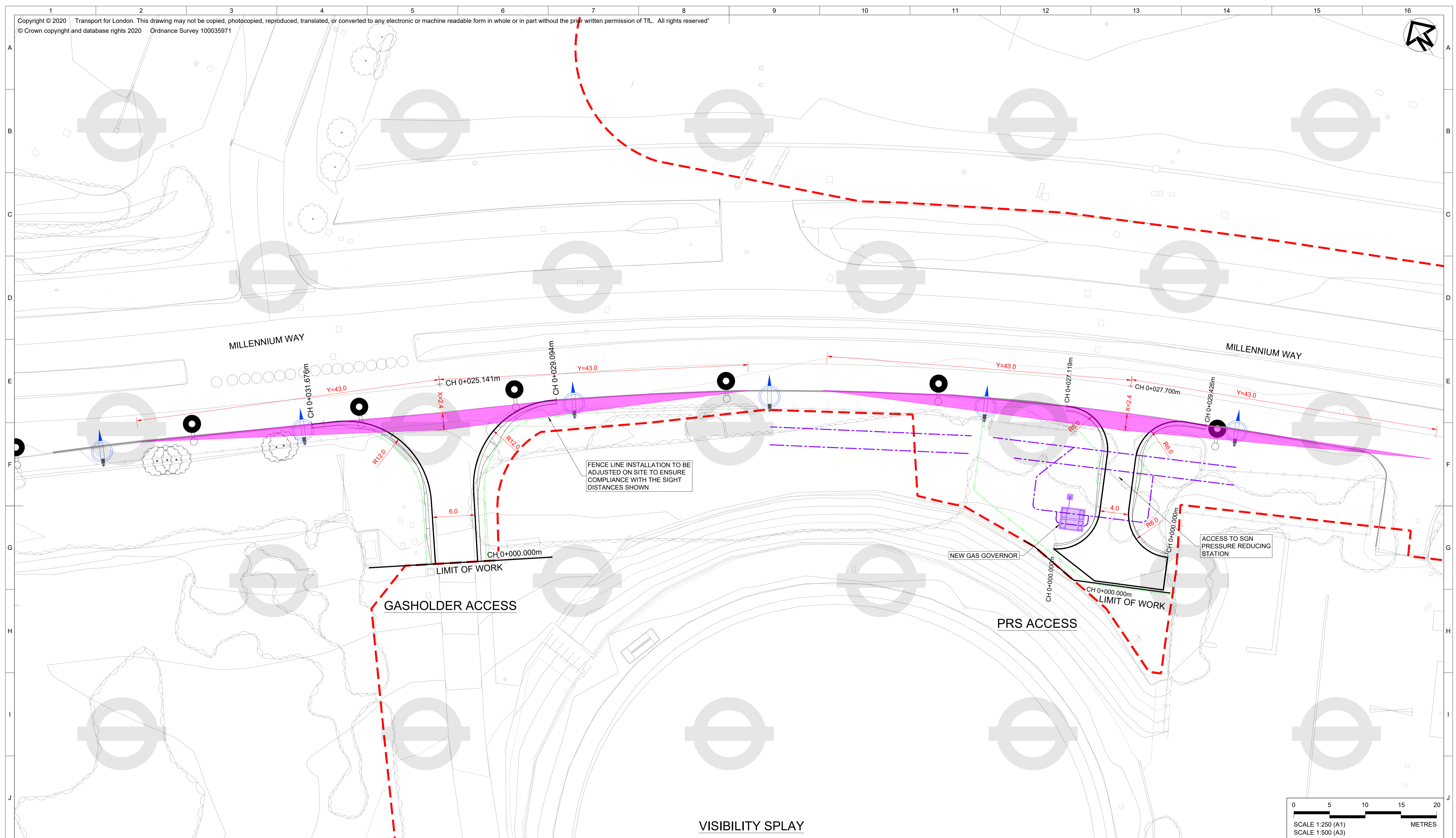
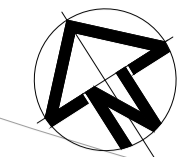

**LEGEND:**

	ORDER LIMITS		SUGGESTED LIGHTING COLUMN (REFER TO NOTES)
	EXISTING FEATURES		VISIBILITY ENVELOPE
	PROPOSED KERB		
	PROPOSED FENCE		
	EXISTING FENCE		
	GAS MAIN		
	EXISTING VEGETATION		
	EXISTING TREE CANOPY		

Restricted	Project	Silvertown Tunnel	
	Originator	Arcadis	
	Location	Greenwich	
	Asset Classification	Multiple Asset Classification	
	Lifecycle	Detailed Design	
	Suitability	S2	
	Fit for Information	Fit for Information	
	Rev	Date	Purpose / Description
			T. Checked T. Approved P. Approved Authorised
	P02	04/05/20	SP SH
P01	09/04/20	SP SH	

Title		Drawing Supporting SGN PRS Consent Submission
		Visibility Splay Verification
Drawing Number		ST150030-ARC-MAC-06-S10-SKE-HE-0005
Rev.		P02



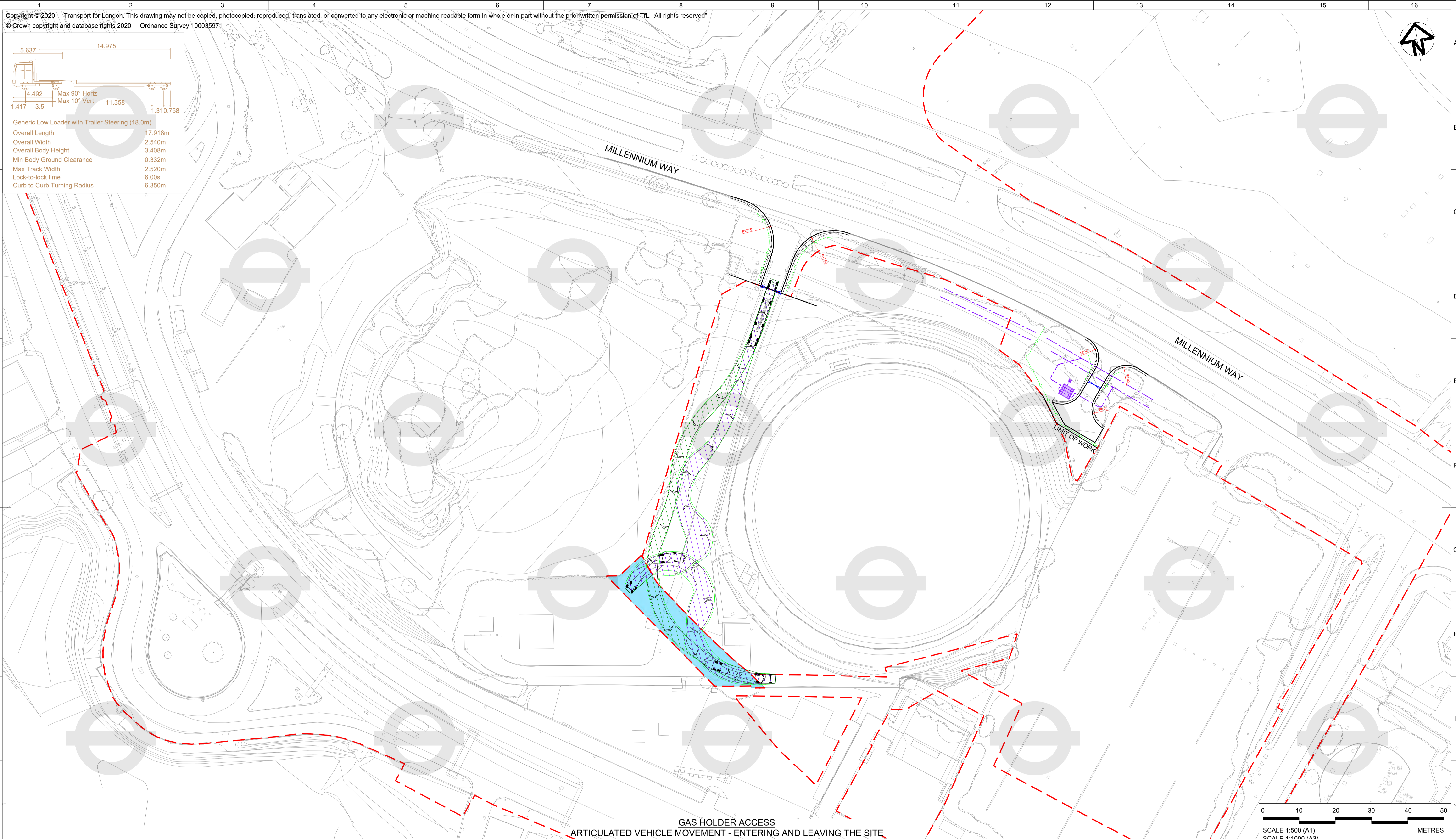
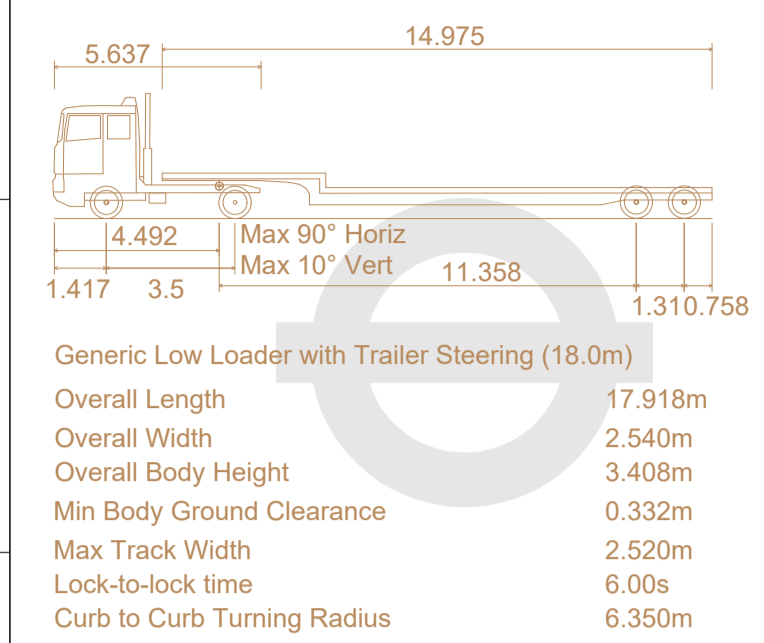

**GAS HOLDER ACCESS  
 ARTICULATED VEHICLE MOVEMENT - ENTERING AND LEAVING THE SITE**

**LEGEND:**

	ORDER LIMITS		VEHICLE IN
	EXISTING FEATURES		VEHICLE OUT
	PROPOSED KERB		TEMPORARY POSSESSION WITH EASEMENT
	GAS MAIN		
	PROPOSED FENCE		
	EXISTING TREE CANOPY		
	PROPOSED GATE		

**NOTES:**  
 1. VEHICLE TO ENTER AND EXIT SITE IN FORWARD GEAR.

Restricted	SP	SH	---	---	---		
	---	---	---	---	---		
Rev	Date	Purpose / Description		T. Checked	T. Approved	P. Approved	Authorised

Project	Silvertown Tunnel
Originator	Arcadis
Location	Greenwich
Asset Classification	Multiple Asset Classification
Lifecycle	Detailed Design
Suitability	S2
Fit for Information	Fit for Information

Title	
SGN PRS Access Swept Path and Access Arrangements	
Gas Holder Access Vehicular Swept Path	
Drawing Number	Rev.
ST150030-ARC-MAC-06-S10-SKE-HE-0010	P01



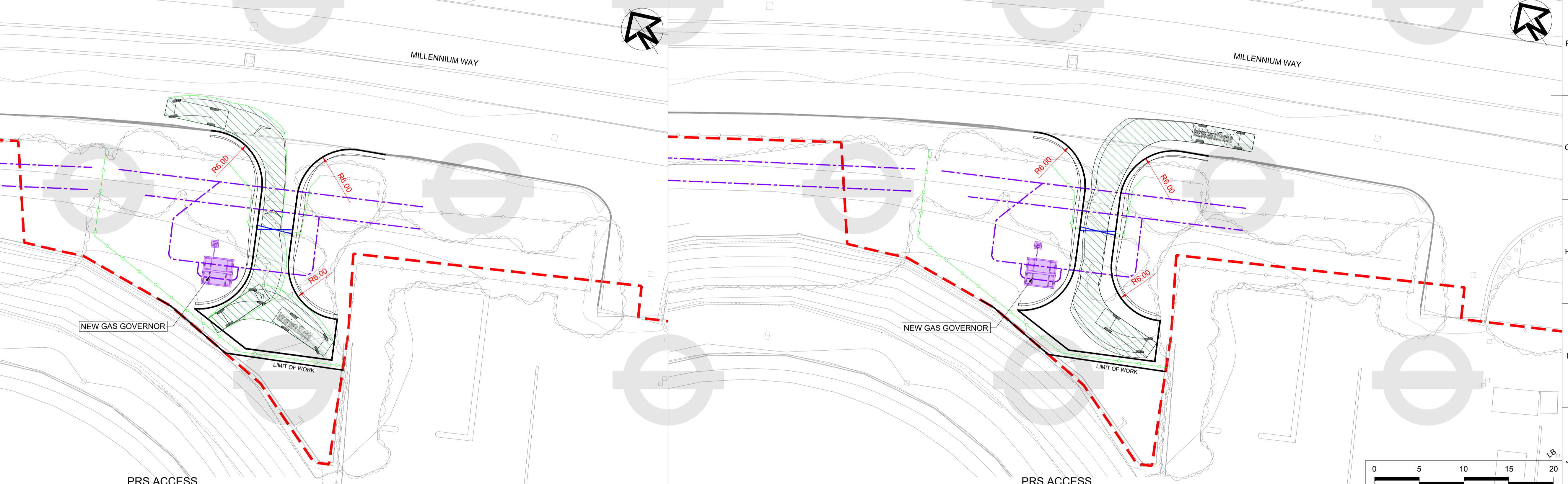
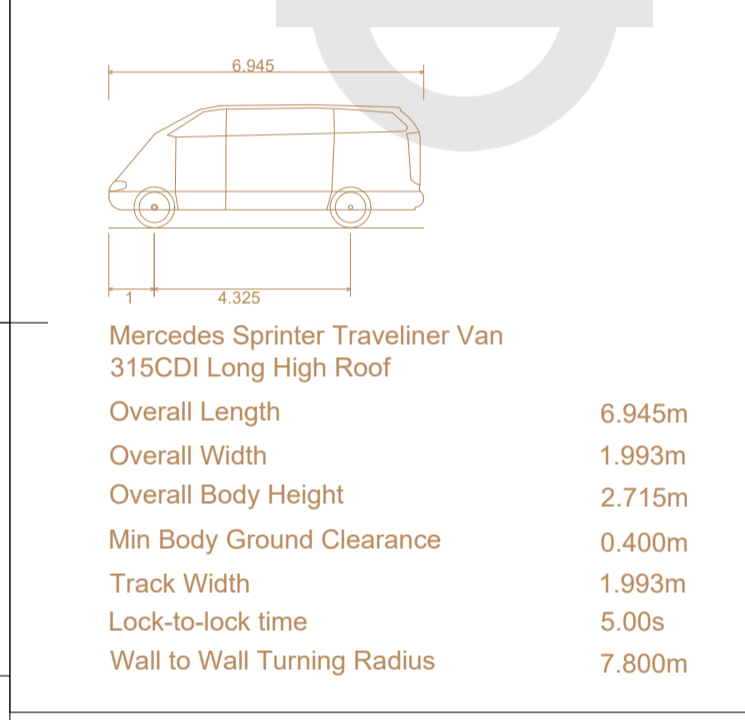
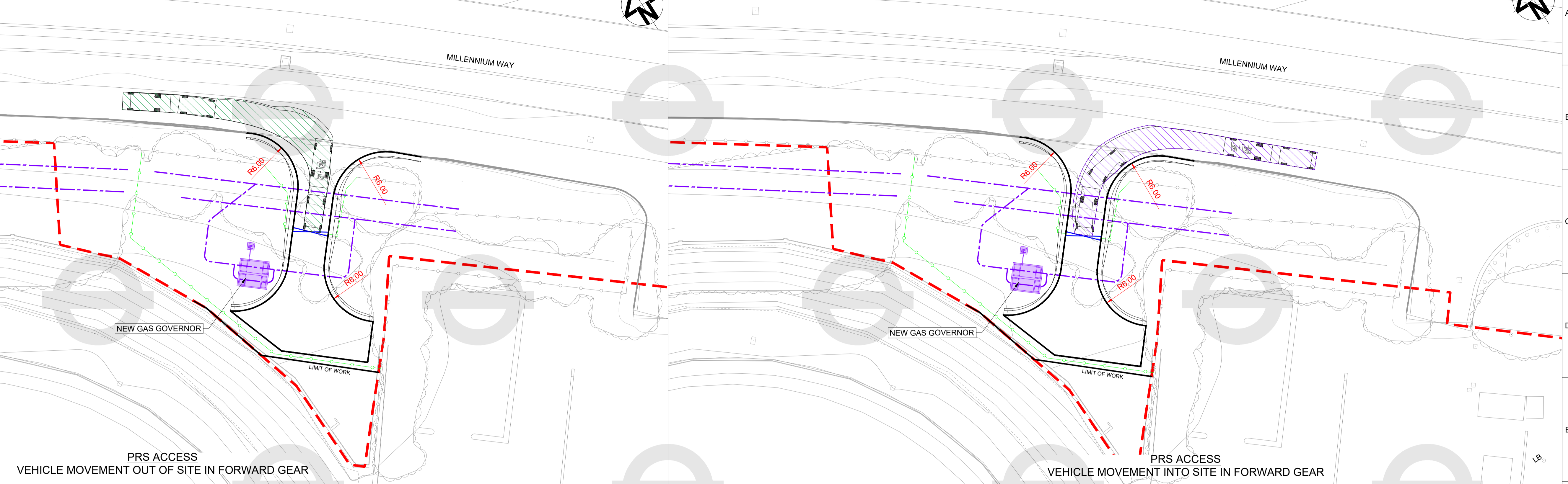
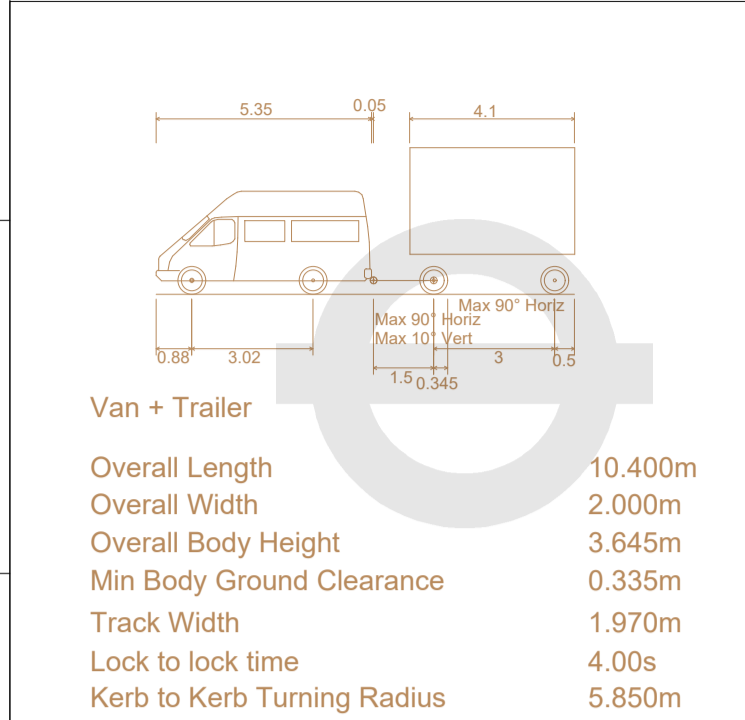

**LEGEND:**

- ORDER LIMITS
- EXISTING FEATURES
- PROPOSED KERB
- GAS MAIN
- PROPOSED FENCE
- EXISTING TREE CANOPY
- PROPOSED GATE
- VEHICLE IN
- VEHICLE OUT

**NOTES:**

- THE SGN SPECIFIED DESIGN VAN FOR THE PRS ACCESS CAN SAFELY ENTER THE SITE WITHOUT ANY TEMPORARY TRAFFIC MANAGEMENT.
- VAN WITH TRAILER PULLS INTO THE ACCESS, STOPPING IN FRONT OF THE GATE.
- GATE IS MANUALLY OPENED AND TRAILER GETS UNCOUPLED FROM VAN.
- WHILST WITHIN THE COMPOUNDS OF ACCESS 2, SGN STAFF TO MANUALLY OPERATE THE TRAILER WITHIN THEIR SITE TO TURN IT AROUND. THE TRANSIT VAN SHALL BE TURNED AROUND SEPARATELY.
- THE TRAILER IS RE-COUPLED, GATE IS CLOSED MANUALLY AND VEHICLE DEPARTS IN FORWARD GEAR.
- IF THE VAN AND TRAILER USED BY THE PRS MAINTENANCE TEAM WILL PROTRUDE INTO MILLENNIUM WAY, SGN IS TO EMPLOY TRAFFIC MANAGEMENT DURING ACCESS AND EGRESS TO/FROM PRS ACCESS TO ENSURE NO HAZARDS ARE POSED TO THE TRAFFIC ON MILLENNIUM WAY.

Rev	Date	Purpose / Description	T. Checked	T. Approved	P. Approved	Authorised
P01	09/04/20	SP	SH	---	---	---
S2		Fit for Information				

**Project**  
Silvertown Tunnel

**Originator**  
Arcadis

**Location**  
Greenwich

**Asset Classification**  
Multiple Asset Classification

**Lifecycle**  
Detailed Design

**Suitability**  
S2

**Title**  
SGN PRS Access Swept Path and Access Arrangements  
Detail Design Vehicular Swept Path

**Drawing Number**  
ST150030-ARC-MAC-06-S10-SKE-HE-0007

**Rev.**  
P01



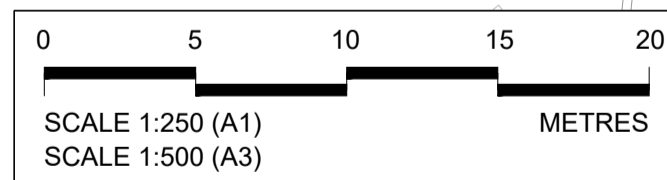
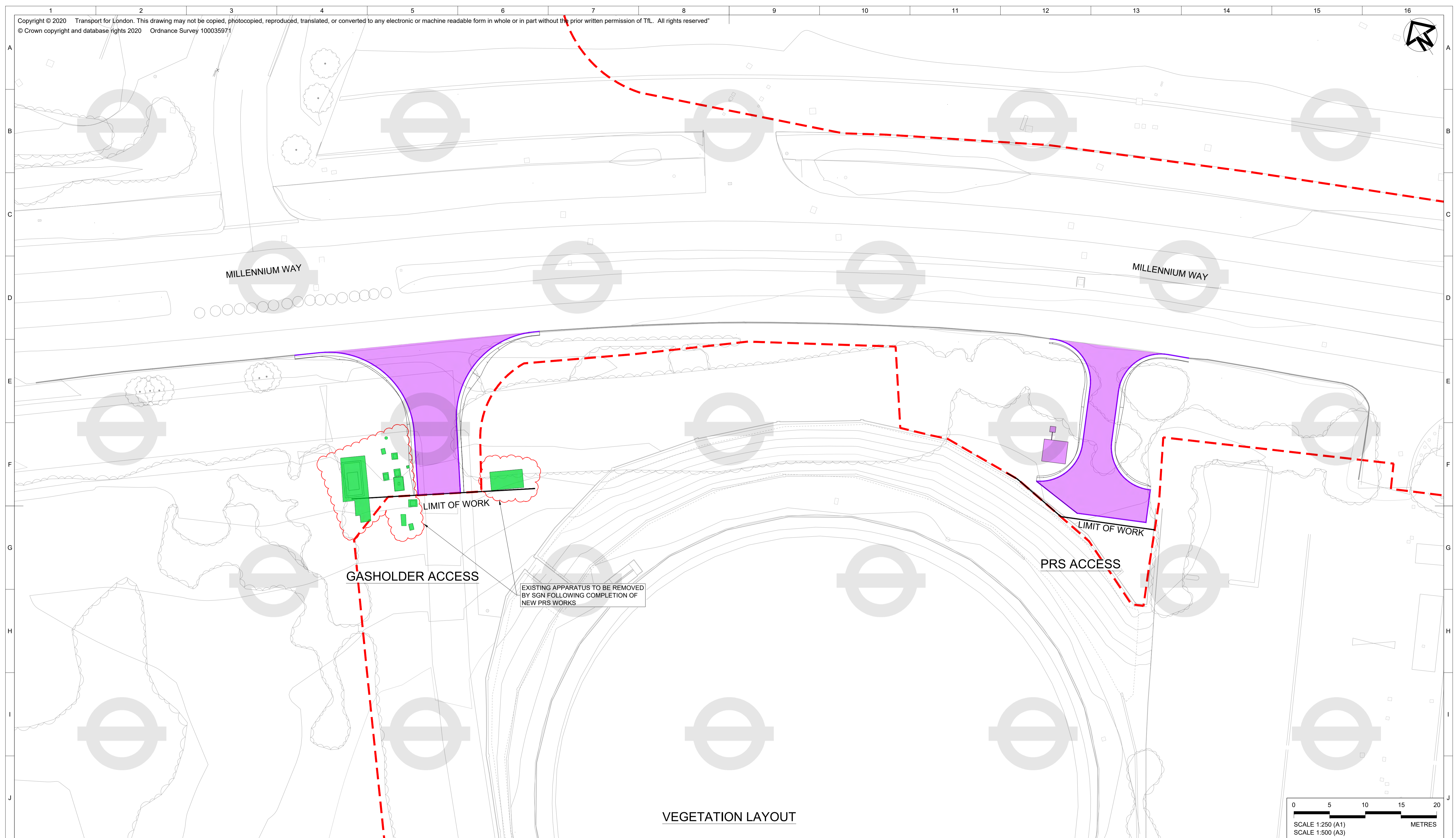
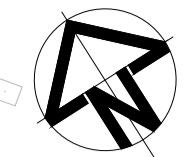

**LEGEND:**

- - - ORDER LIMITS
- EXISTING FEATURES
- VEGETATION REPLACED BY NEW CONSTRUCTION
- INTRODUCE NEW VEGETATION SIMILAR TO EXISTING

Restricted	Project					Title														
	Silvertown Tunnel					Drawing Supporting SGN PRS Consent Submission														
	Originator					Vegetation Layout														
	Arcadis																			
Location																				
Greenwich																				
Asset Classification																				
Multiple Asset Classification																				
Lifecycle																				
Detailed Design																				
Suitability																				
S2					Fit for Information															
<table border="1" style="width: 100%; border-collapse: collapse; font-size: small;"> <thead> <tr> <th>Rev</th> <th>Date</th> <th>Purpose / Description</th> <th>T. Checked</th> <th>T. Approved</th> <th>P. Approved</th> <th>Authorised</th> </tr> </thead> <tbody> <tr> <td>P01</td> <td>09/04/20</td> <td>SP</td> <td>SH</td> <td>---</td> <td>---</td> <td>---</td> </tr> </tbody> </table>					Rev	Date	Purpose / Description	T. Checked	T. Approved	P. Approved	Authorised	P01	09/04/20	SP	SH	---	---	---	Drawing Number <b>ST150030-ARC-MAC-06-S10-SKE-HE-0008</b>	
Rev	Date	Purpose / Description	T. Checked	T. Approved	P. Approved	Authorised														
P01	09/04/20	SP	SH	---	---	---														
					Rev. <b>P01</b>															



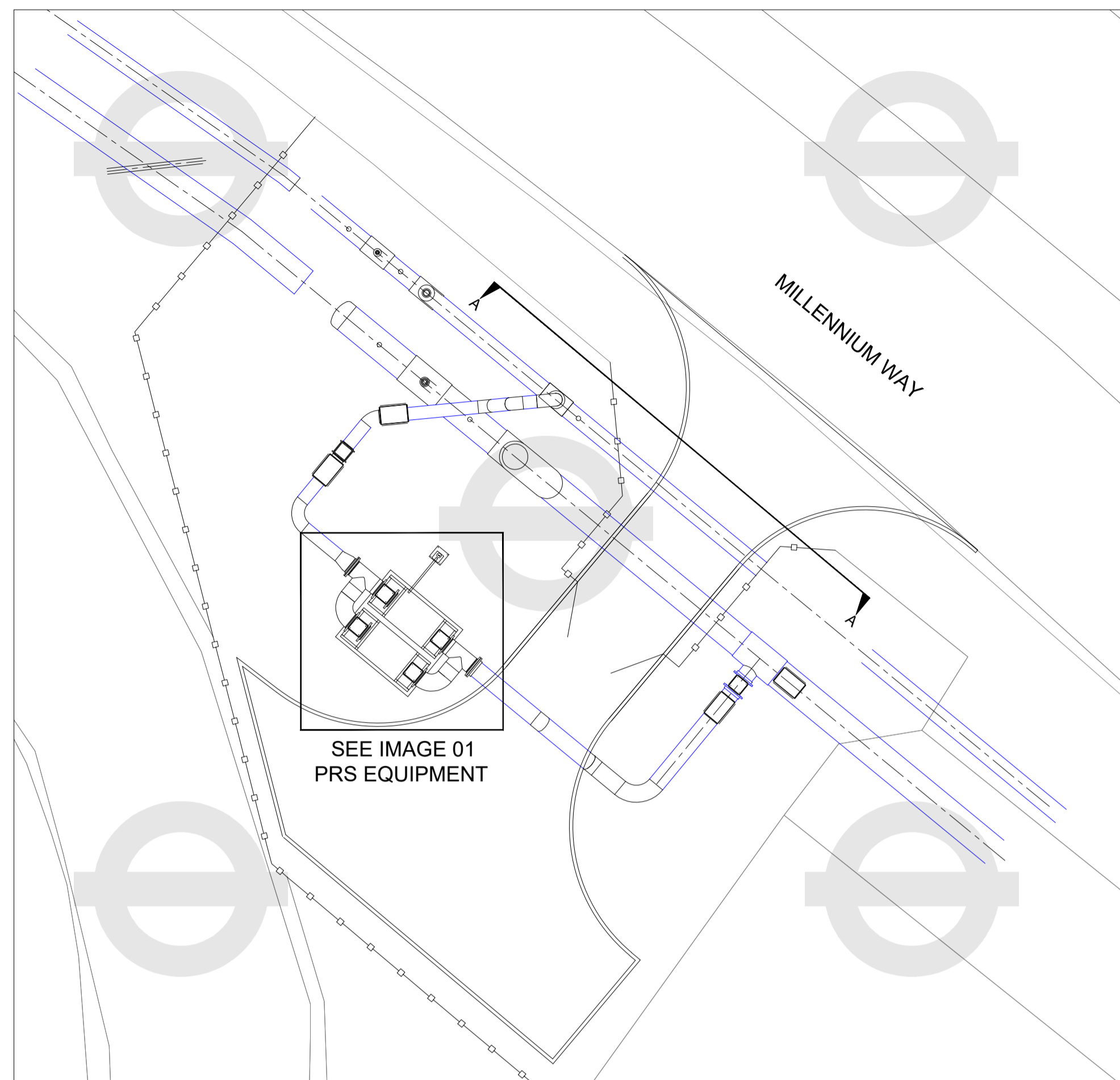

POST CONSTRUCTION LAYOUT



IMAGE 01  
 PRS EQUIPMENT  
 COLOUR OF THE NEW GOVERNOR AS PER PHOTO (LIGHT GREY)

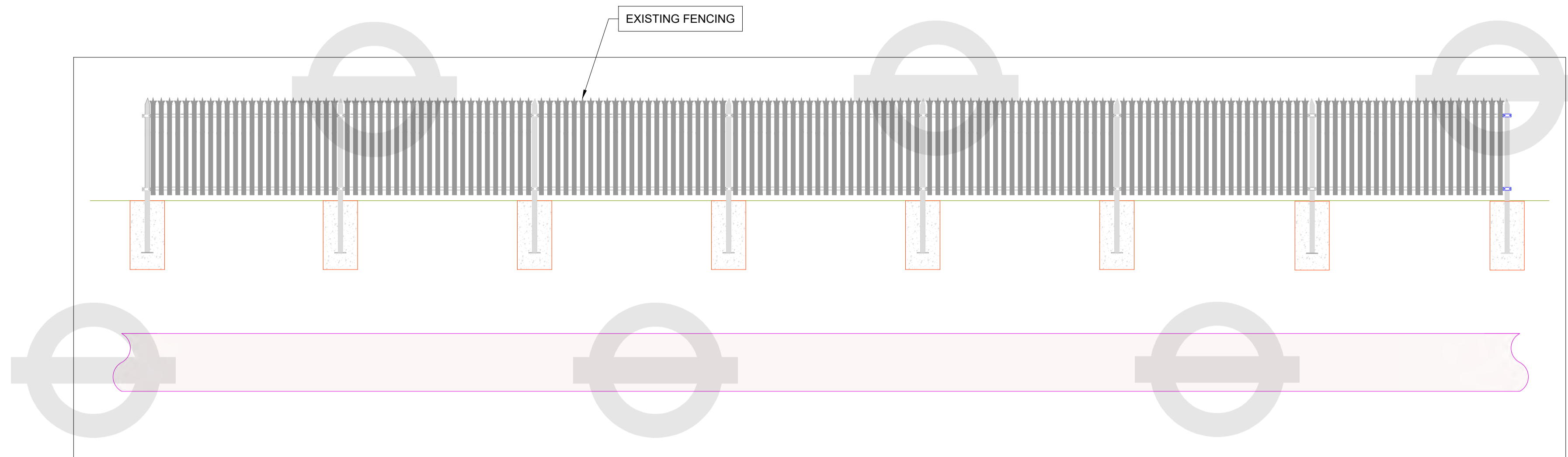

PRE-CONSTRUCTION ELEVATION

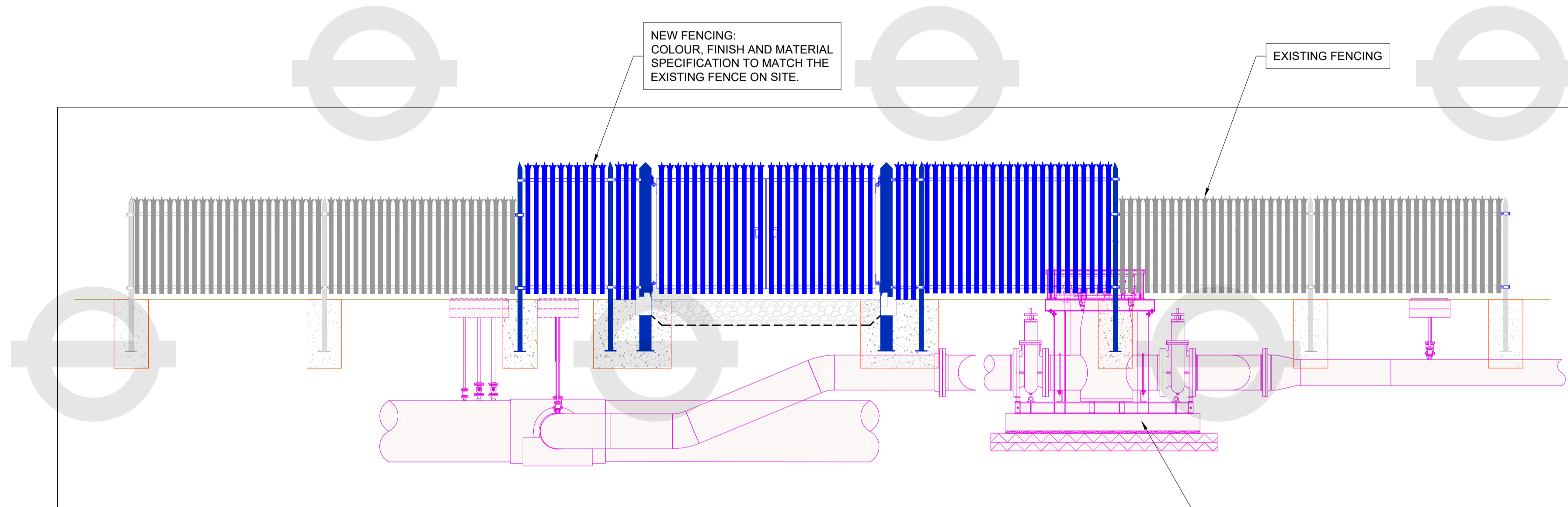

POST-CONSTRUCTION ELEVATION  
 SECTION A-A

NEW PRS INSTALLATION

Restricted

Project Silvertown Tunnel Originator Arcadis Location Greenwich Asset Classification Multiple Asset Classification Lifecycle Detailed Design Suitability S2   Fit for Information	Title Drawing Supporting SGN PRS Consent Submission SGN PRS Access Elevation	
	Drawing Number ST150030-ARC-MAC-06-S10-SKE-HE-0009	
	Rev. P02	
	Rev.	





MILLENNIUM WAY

MILLENNIUM WAY

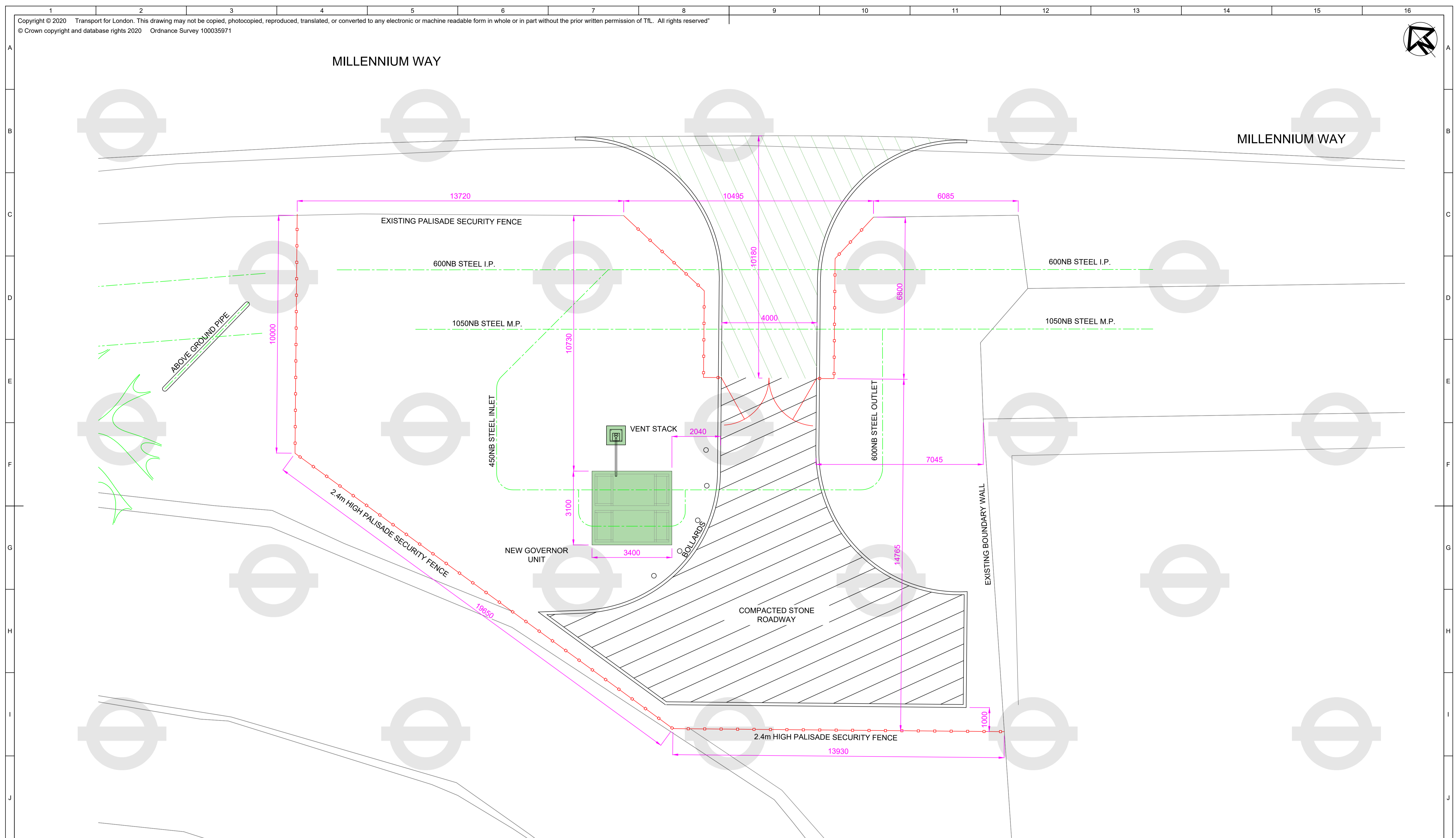

**NOTES:**  
 1. ALL DIMENSIONS ARE IN MILLIMETRES UNLESS OTHERWISE STATED.

Restricted

Rev	Date	Drawn	T. Checked	T. Approved	P. Approved	Authorised
P01	13/04/20	HGS	SH	---	---	---

Project	Silvertown Tunnel
Originator	RiverLinX CJV
Location	Greenwich
Asset Classification	Multiple Asset Classification
Lifecycle	Detailed Design
Suitability	S2   Fit for Information

Title	
Drawing Supporting SGN PRS Consent Submission Governor Replacement Civil Site Layout	
Drawing Number	Rev.
ST150030-RLC-MAC-06-S10-SKE-HE-0001	P01

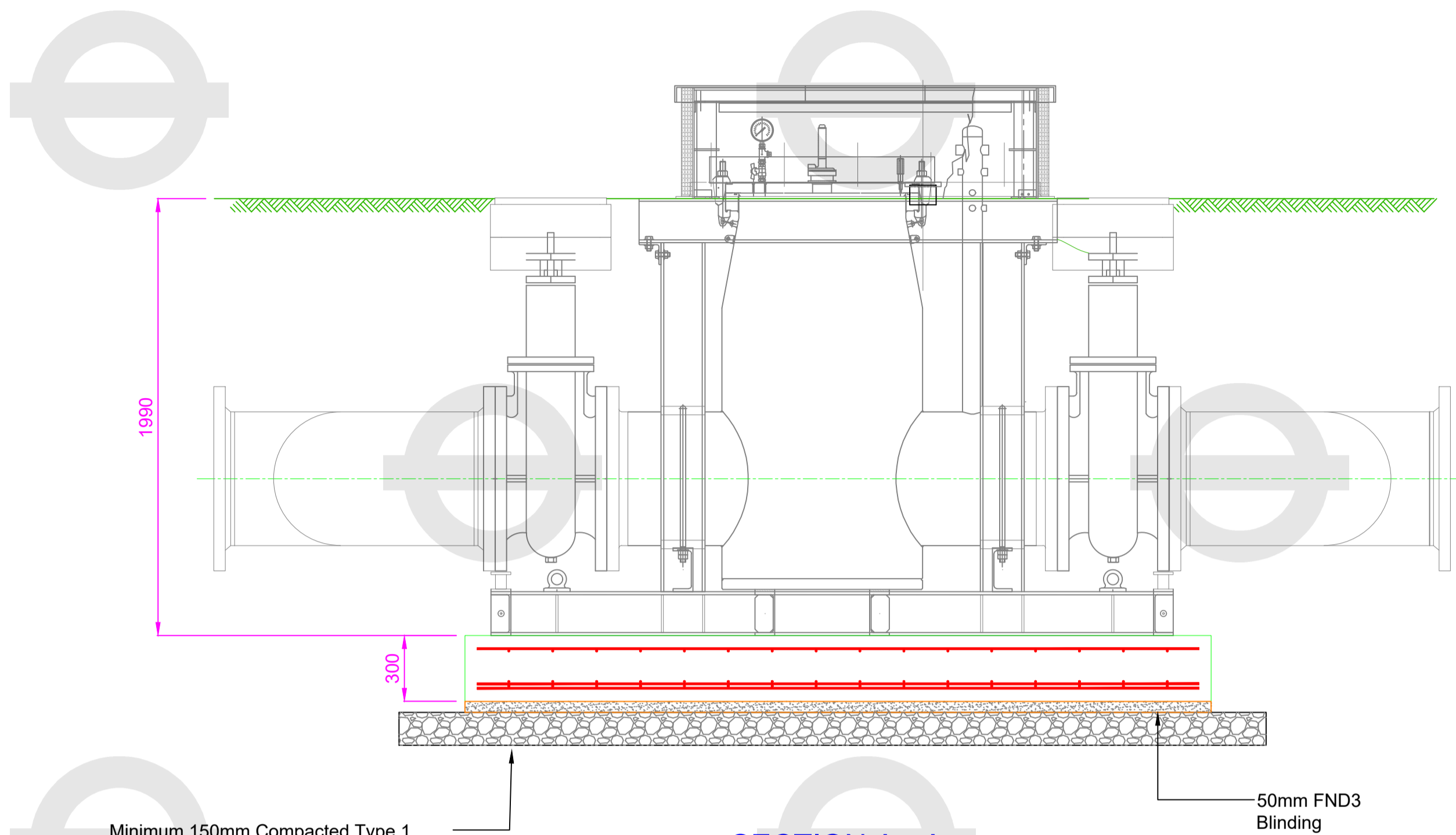

**SECTION A - A**  
SCALE 1 : 20

Minimum 150mm Compacted Type 1 Material. Sub-Base To Extend Min. 250mm Clear Of Concrete Foundations In All Directions.

50mm FND3 Blinding

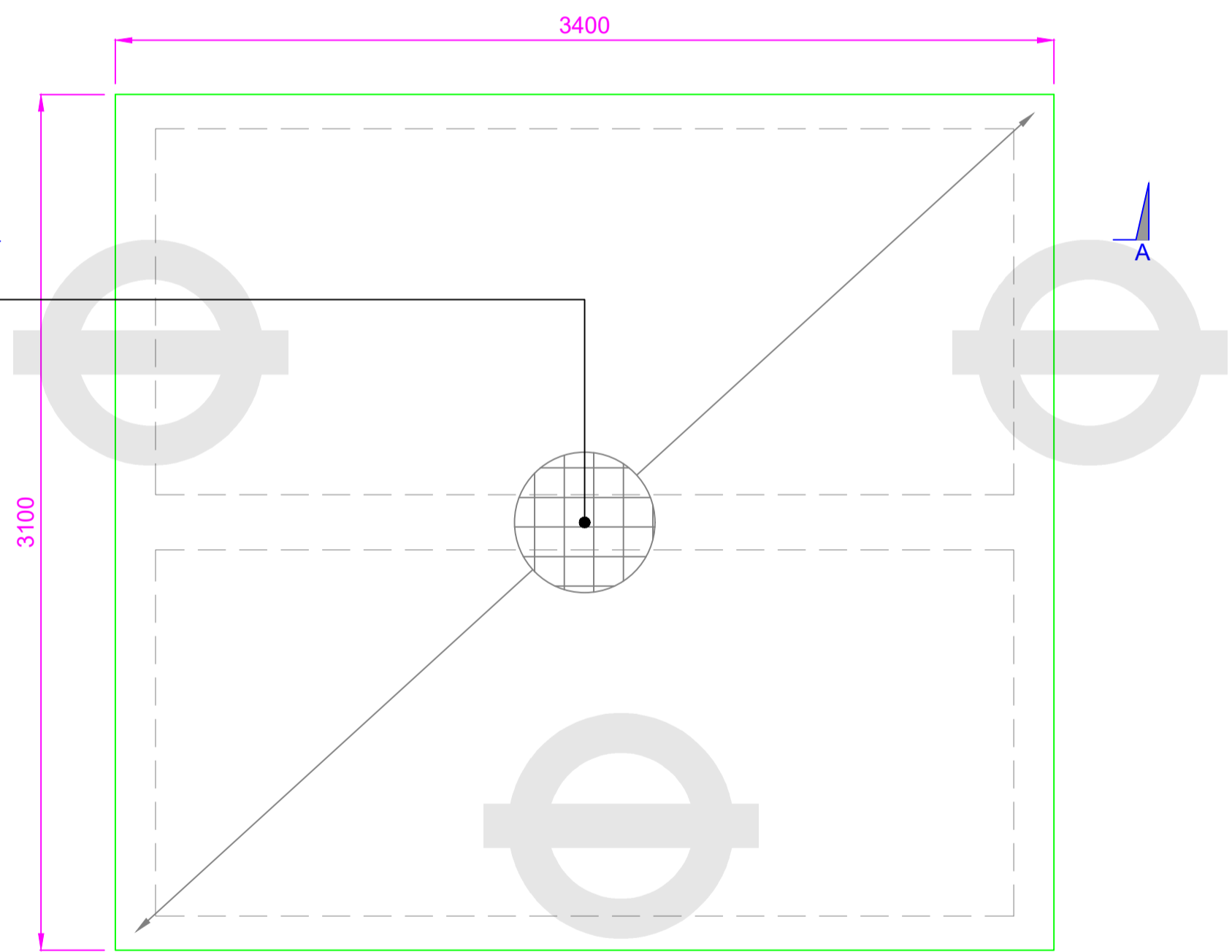

**PLAN VIEW**  
SCALE 1 : 20

3 Layers A393 Mesh  
1 Top, 2 Bottom. Min  
55mm Cover.

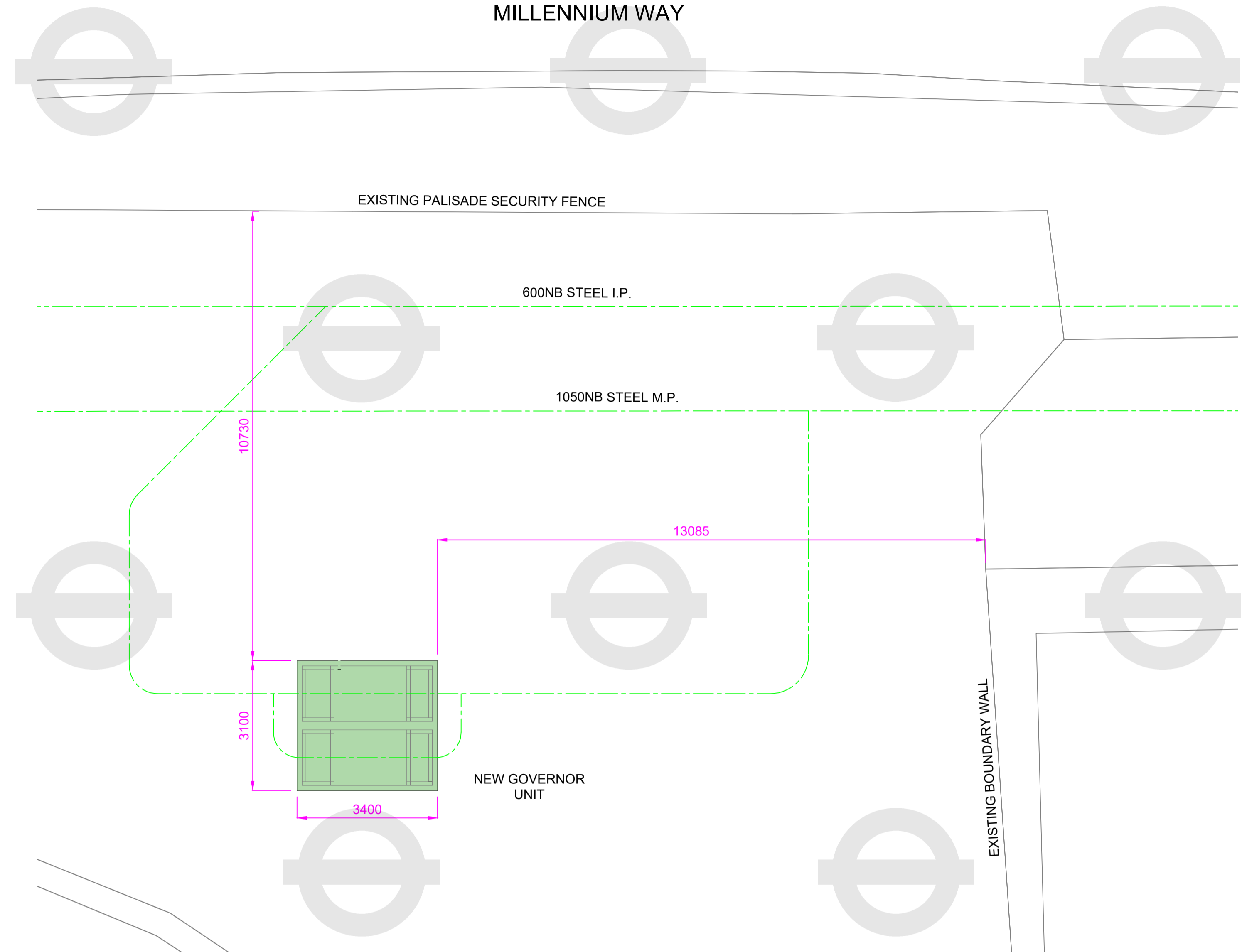

**LOCATION PLAN**  
SCALE 1 : 75

MILLENNIUM WAY

EXISTING PALISADE SECURITY FENCE

600NB STEEL I.P.

1050NB STEEL M.P.

NEW GOVERNOR UNIT

EXISTING BOUNDARY WALL

**NOTES:**  
1. ALL DIMENSIONS ARE IN MILLIMETRES UNLESS OTHERWISE STATED.

Restricted

Rev	Date	Drawn	T. Checked	T. Approved	P. Approved	Authorised
P01	13/04/20	HGS	SH	---	---	---

Project	Silvertown Tunnel
Originator	RiverLinx CJV
Location	Greenwich
Asset Classification	Multiple Asset Classification
Lifecycle	Detailed Design
Suitability	S2   Fit for Information

Title	
Drawing Supporting SGN PRS Consent Submission	
Governor Replacement Skid Foundation	
Drawing Number	Rev.
ST150030-RLC-MAC-06-S10-SKE-HE-0002	P01

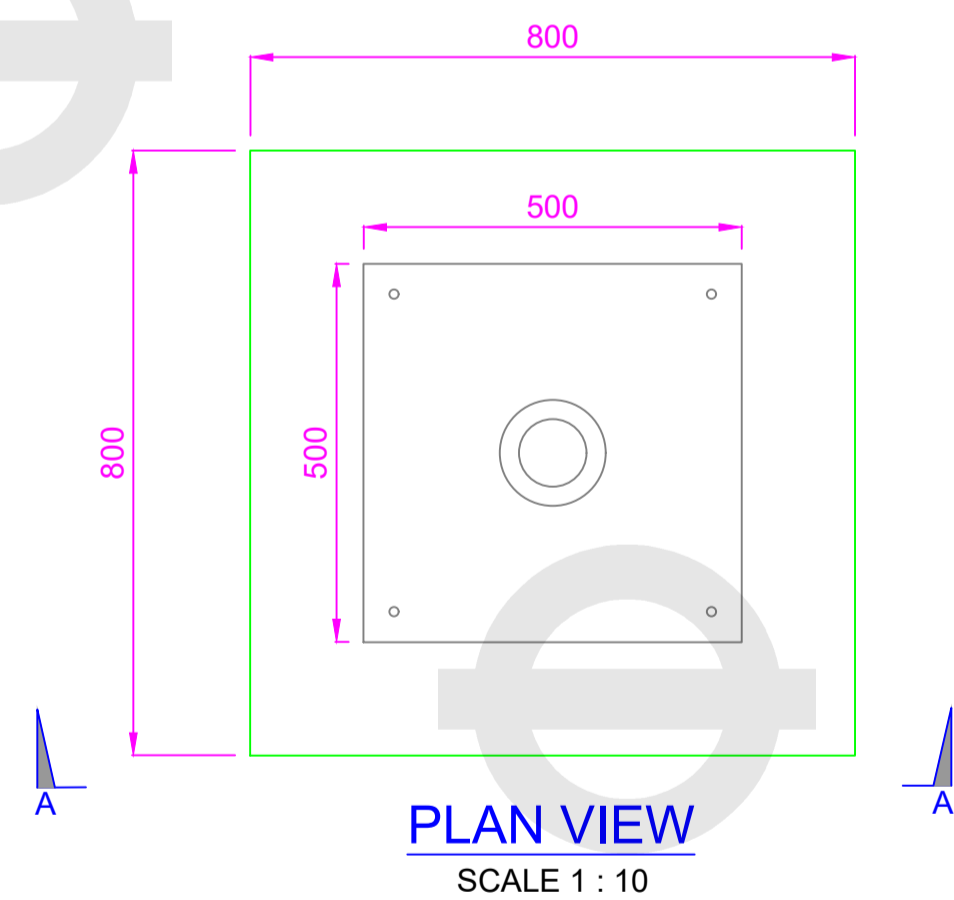
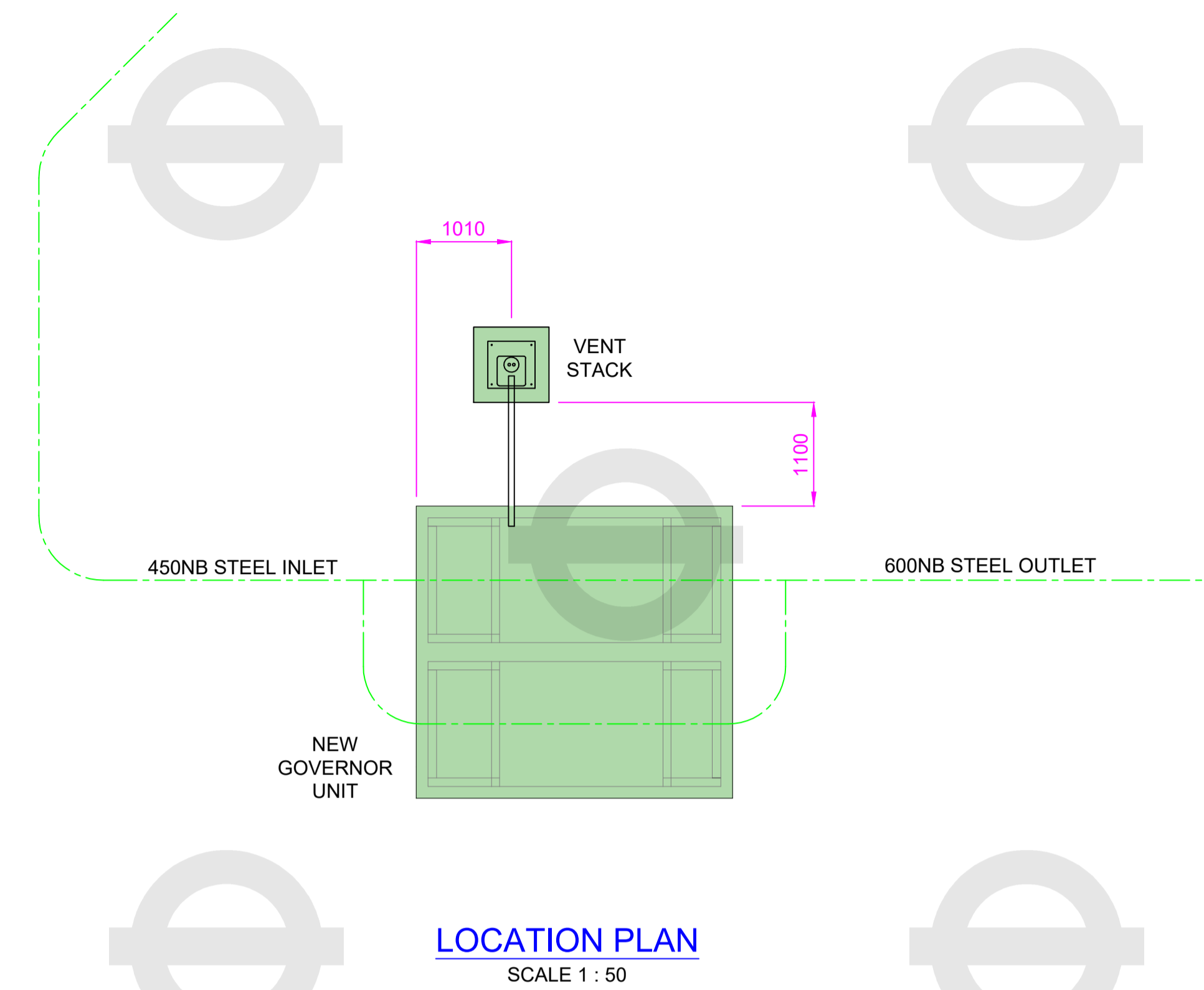
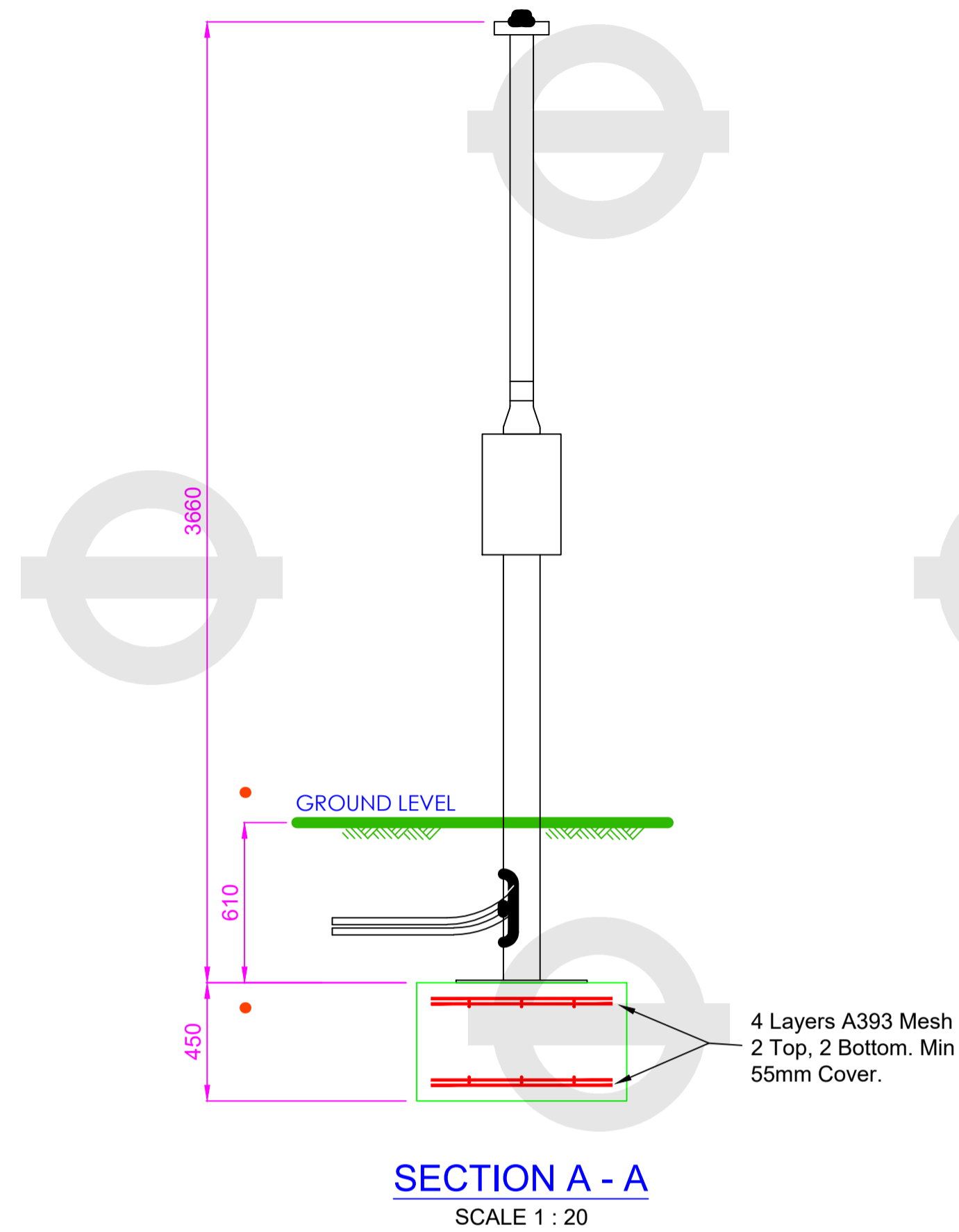

**NOTES:**  
 1. ALL DIMENSIONS ARE IN MILLIMETRES UNLESS OTHERWISE STATED.

Restricted

Rev	Date	Drawn	T. Checked	T. Approved	P. Approved	Authorised
P01	13/04/20	HGS	SH	---	---	---

Project	Silvertown Tunnel
Originator	RiverLinX CJV
Location	Greenwich
Asset Classification	Multiple Asset Classification
Lifecycle	Detailed Design
Suitability	S2   Fit for Information

Title	Drawing Supporting SGN PRS Consent Submission Governor Replacement Vent Stack Foundation
Drawing Number	ST150030-RLC-MAC-06-S10-SKE-HE-0003
Rev.	P01



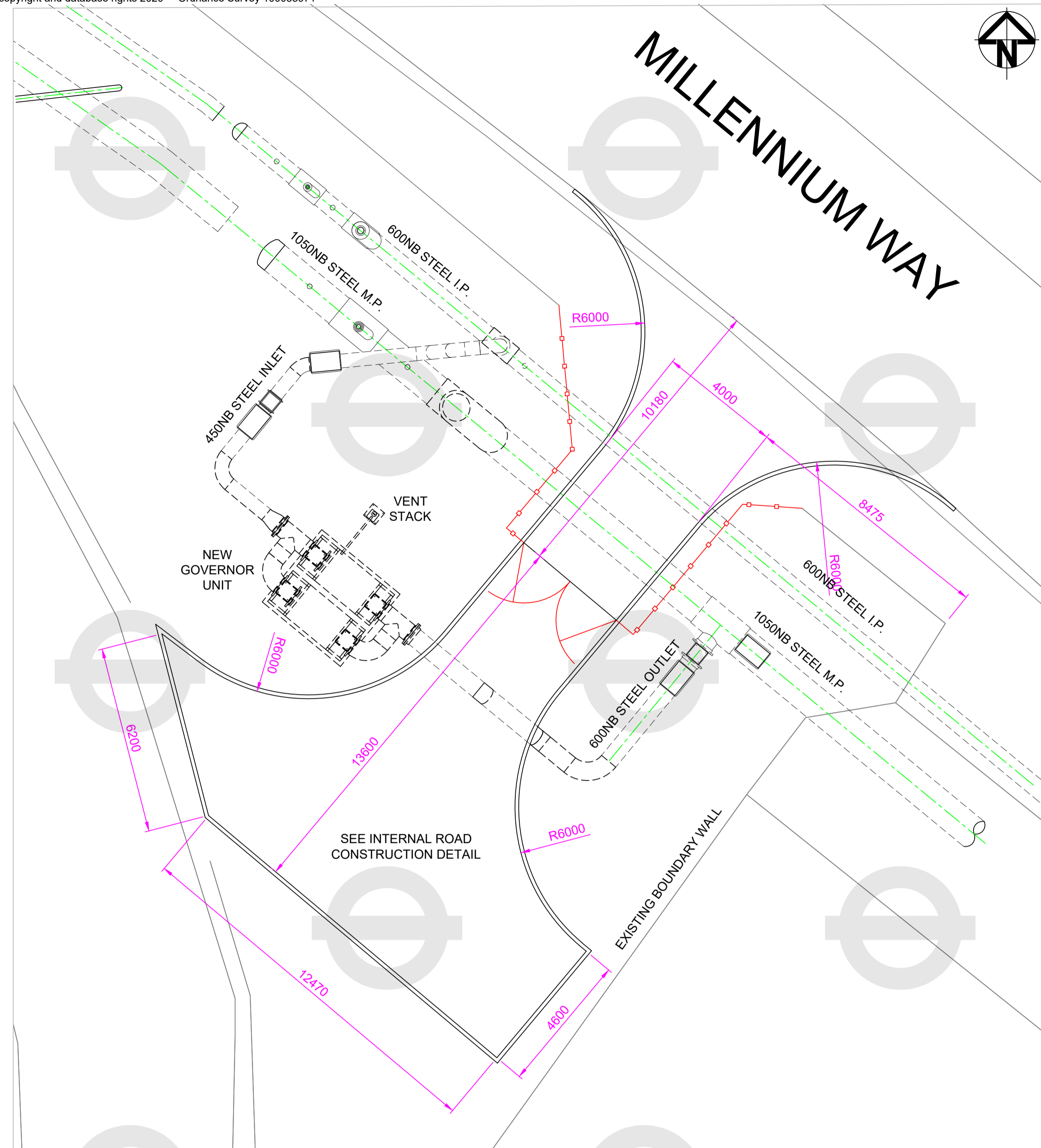

**LOCATION PLAN**  
 SCALE 1:200 @ A1

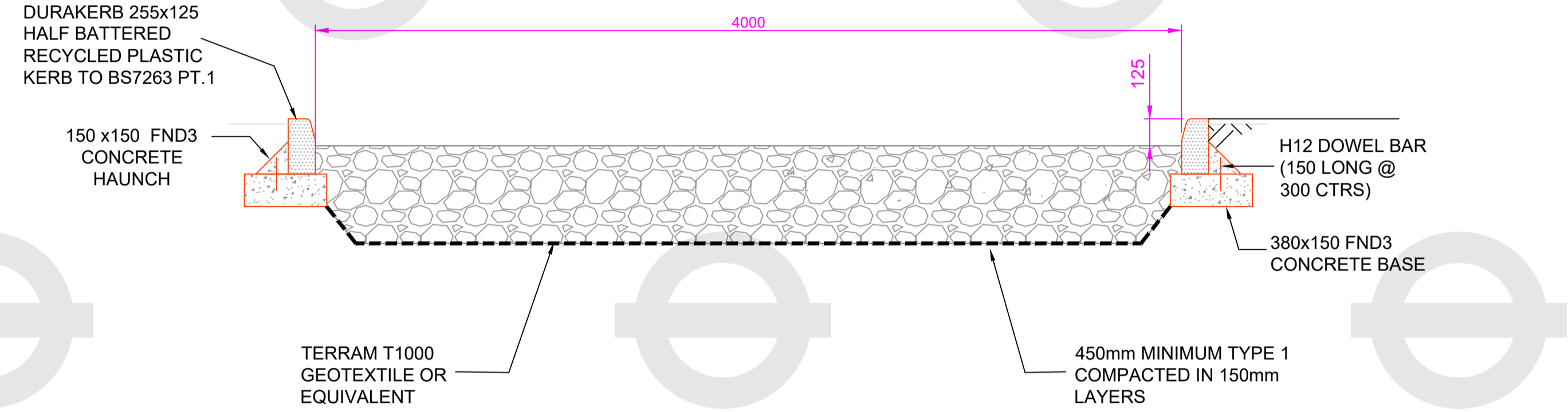

**INTERNAL ROAD CONSTRUCTION DETAIL**  
 SCALE 1 : 20

**NOTES:**  
 1. ALL DIMENSIONS ARE IN MILLIMETRES UNLESS OTHERWISE STATED.

Restricted	Project	Silvertown Tunnel	Title	Drawing Supporting SGN PRS Consent Submission					
	Originator	RiverLinX CJV	Location	Greenwich					
	Asset Classification	Multiple Asset Classification	Lifecycle	Detailed Design					
	Suitability	S2	Fit for Information	Drawing Number					
	Rev	Date	Purpose / Description	Drawn	T. Checked	T. Approved	P. Approved	Authorised	Rev.

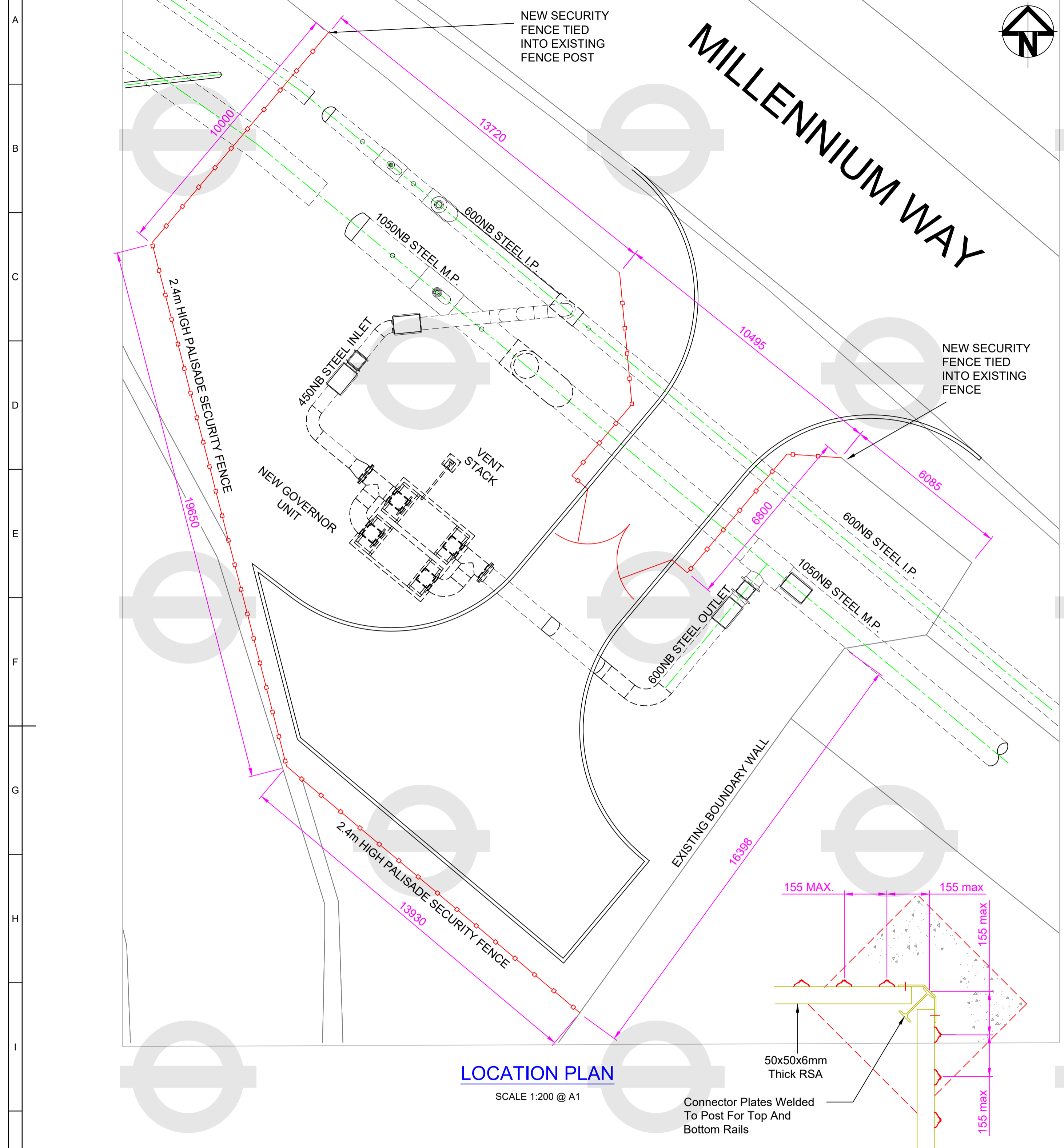

**LOCATION PLAN**  
SCALE 1:200 @ A1

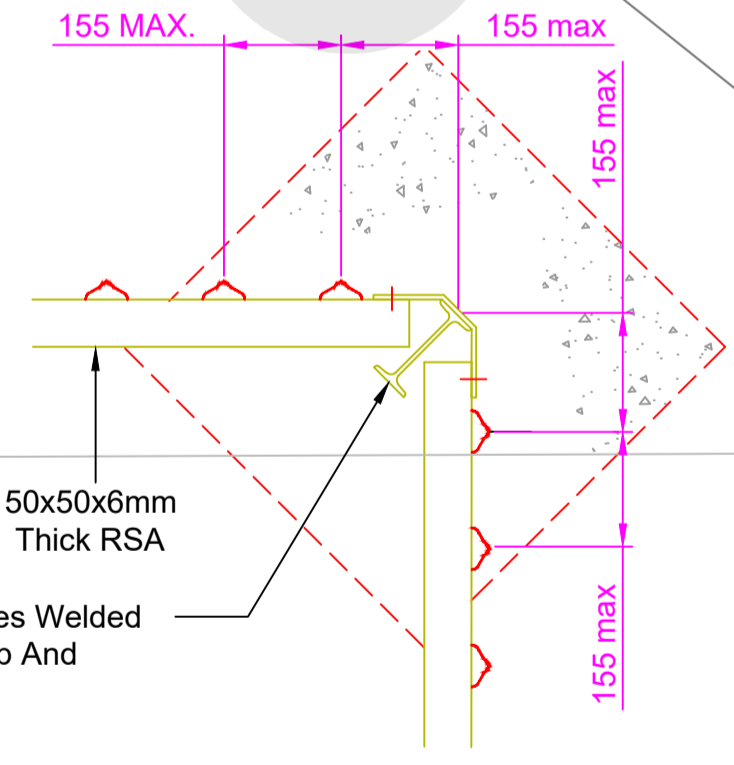

**CORNER FIXING DETAIL**  
SCALE 1:20

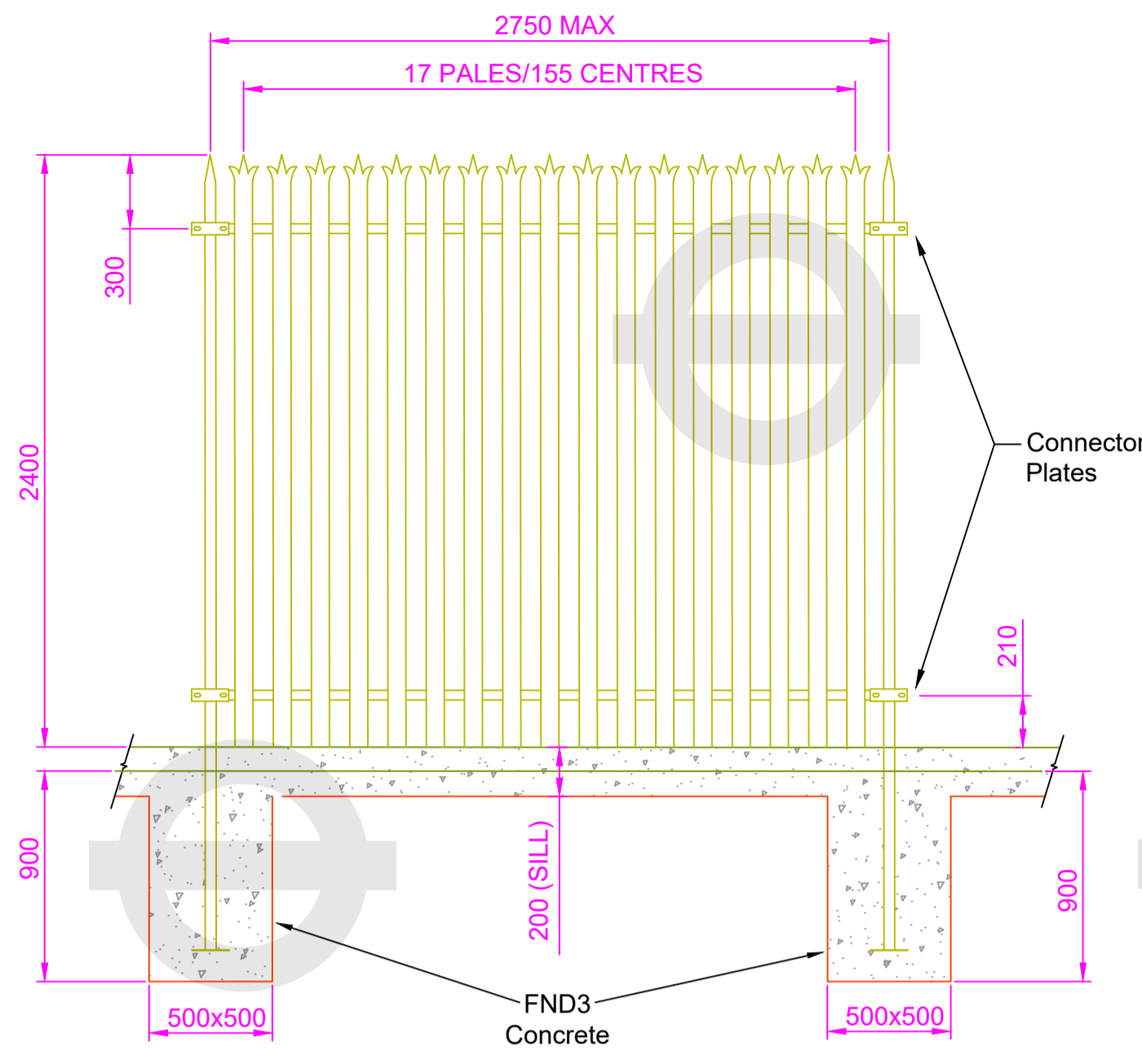

**2.4m HEIGHT PALISADE SECURITY FENCING**  
SCALE 1:25

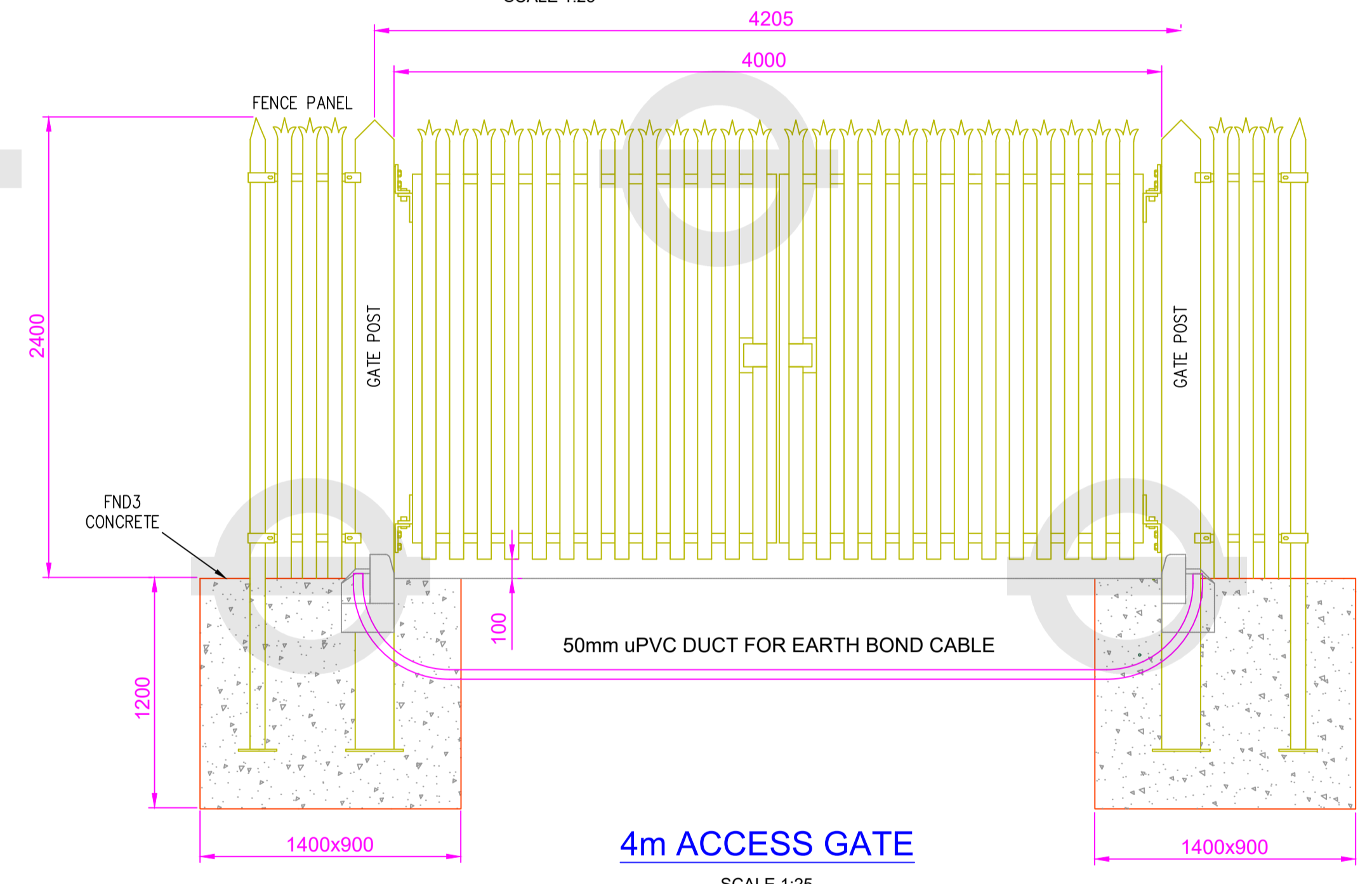

**4m ACCESS GATE**  
SCALE 1:25

**NOTES:**  
1. ALL DIMENSIONS ARE IN MILLIMETRES UNLESS OTHERWISE STATED.

Restricted	Project	Silvertown Tunnel	Title	Drawing Supporting SGN PRS Consent Submission					
	Originator	RiverLinx CJV	Location	Greenwich					
	Asset Classification	Multiple Asset Classification	Lifecycle	Detailed Design					
	Suitability	S2	Fit for Information	Drawing Number					
Rev	Date	Purpose / Description	Drawn	T. Checked	T. Approved	P. Approved	Authorised	Rev.	P01
Project: Silvertown Tunnel Originator: RiverLinx CJV Location: Greenwich Asset Classification: Multiple Asset Classification Lifecycle: Detailed Design Suitability: S2   Fit for Information								Drawing Number: ST150030-RLC-MAC-06-S10-SKE-HE-0005 Rev: P01	



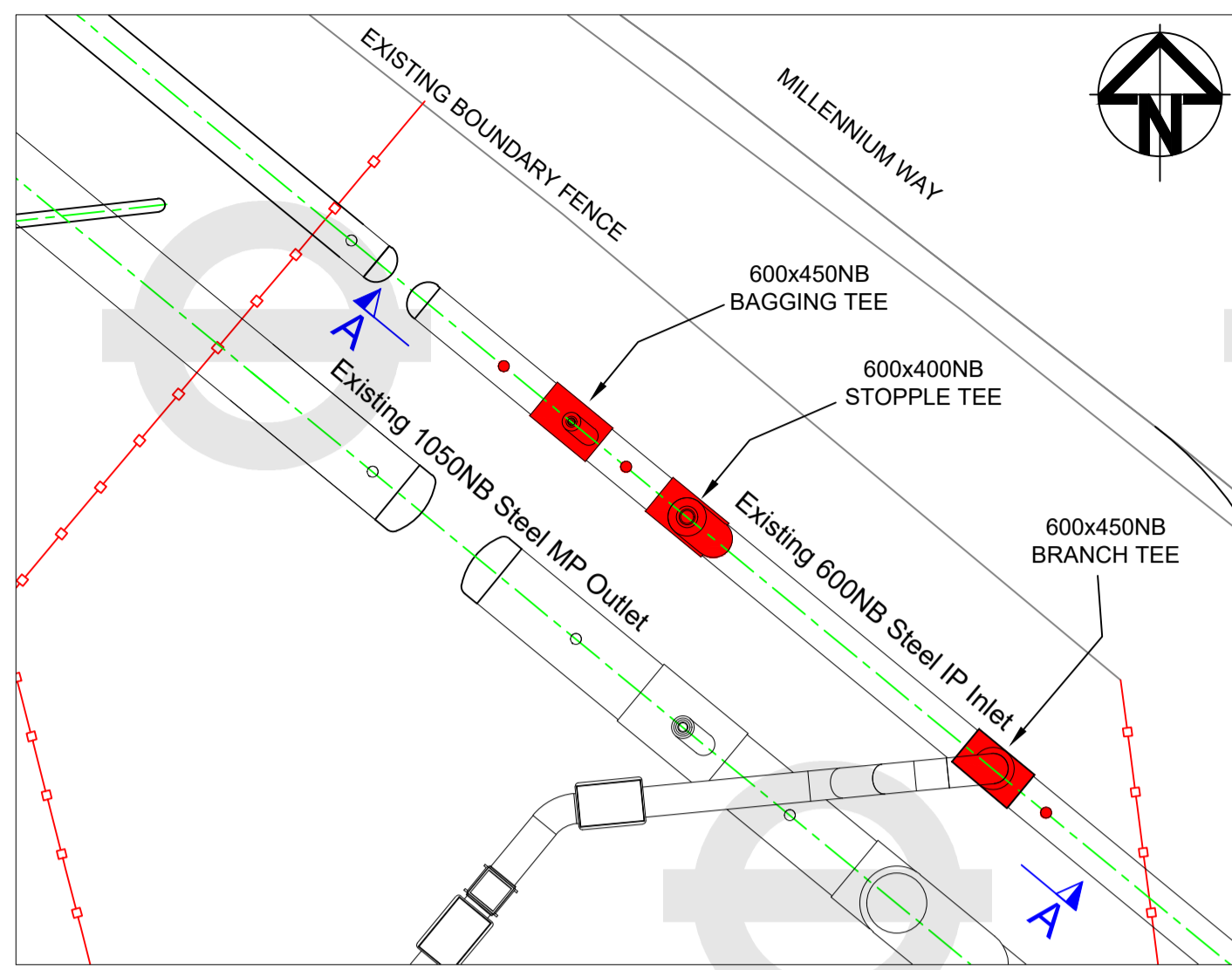

PLAN

MATERIALS

Item No.	Pipe Size	Description	Rating	Spec	Quant
T1501	600NB	600 x 450NB Welded Split Branch Tee RF Flange	NP16	SGN/SP/F/4	1
T1512	600NB	600 x 400NB Welded Split Stopple Tee c/w L.O.R. RF Flange, Plug & Blind Flange Kit	NP16	SGN/SP/F/4	1
T1513	600NB	600 x 150NB Welded Split Bagging Tee c/w L.O.R. RF Flange, Plug & Blind Flange Kit	NP16	SGN/SP/F/4	1
EC028	600NB	End Cap - To Suit 8mm Wall Thickness Coated To SGN/SP/CW/6	---	ASME B16.9	2
V812	50NB	Ball Valve Full Bore - RF / RF - Steel Bodied	NP16	SGN/SP/V/6 Pt.2	4
V1169	450NB	Gate Valve Full Bore - RF / RF - Steel Bodied	NP16	GIS / V7	1
V1511	400NB	Sandwich Valve - Supplied By Drilling Contractor	NP16	---	1
V1513	150NB	Sandwich Valve - Supplied By Drilling Contractor	NP16	---	1
F578	450NB	Flange - WNRF, L245, Coated to SGN/SP/CW/6	NP16	GIS / F7	1
F1083	50NB	Flange - Blind, Raised Face, L245, Coated to SGN/SP/CW/6	NP16	GIS / F7	4
F1791	50NB	Weldoflange Raised Face off 600NB - With TOR	NP16	GIS / F7	4

MATERIALS

Item No.	Pipe Size	Description	Rating	Spec	Quant
G044	450NB	Gasket - CNAF To Suit RF Flange	NP16	GIS / F7	2
G052	400NB	Gasket - CNAF To Suit RF Flange	NP16	GIS / F7	1
G084	150NB	Gasket - CNAF To Suit RF Flange	NP16	GIS / F7	1
G116	50NB	Gasket - CNAF To Suit RF Flange	NP16	GIS / F7	8
SB055	-	Studbolts A320 (L7) M27 x 145mm Long Complete With 2H Nuts & Washers To Suit RF Flange	-	BS EN 1515-2	40
SB065	-	Studbolts A320 (L7) M27 x 135mm Long Complete With 2H Nuts & Washers To Suit RF Flange	-	BS EN 1515-2	16
SB105	-	Studbolts A320 (L7) M20 x 95mm Long Complete With 2H Nuts & Washers To Suit RF Flange	-	BS EN 1515-2	8
SB145	-	Studbolts A320 (L7) M16 x 80mm Long Complete With 2H Nuts & Washers To Suit RF Flange	-	BS EN 1515-2	32

NOTE: An Additional 1/4" Has Been Added To The Lengths Quoted In SGN/SP/E/55 To Allow For The Bolt Chamfer

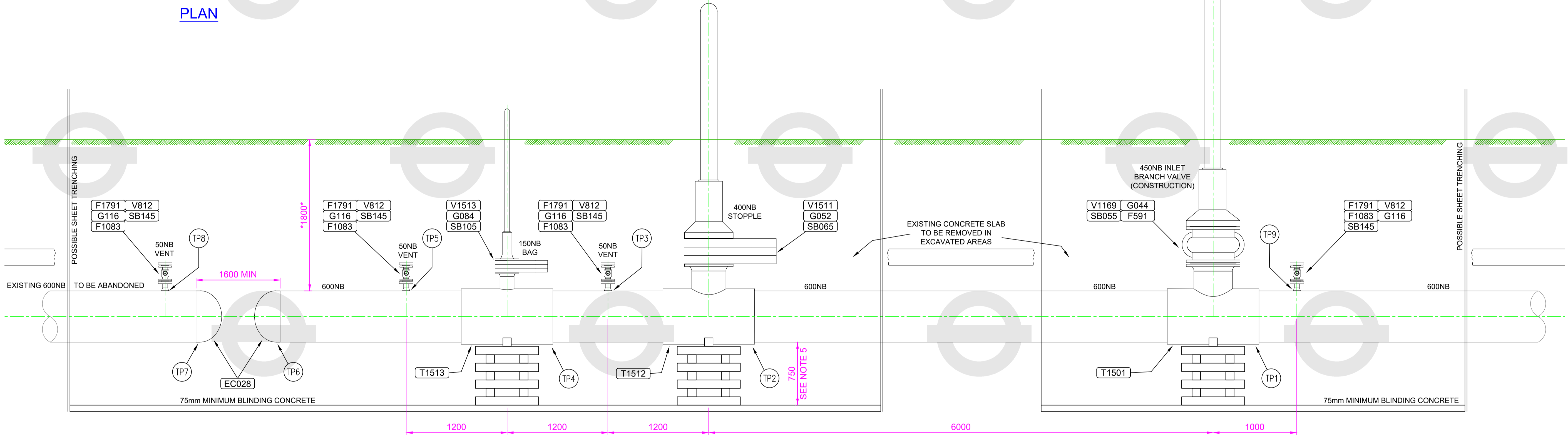

SECTION A - A

PRESSURE TESTING					
Test	Test Section	Pressure (Bar)	Medium	Duration	Specification
Strength test	All Tee's	Line Pressure	Pneumatic	30 minutes	IGEM/TD/13 ED2 & T/PM/MSL/1

NOTES:  
 1. ALL DIMENSIONS ARE IN MILLIMETRES UNLESS OTHERWISE STATED.

Restricted	Project	Silvertown Tunnel	Title	Drawing Supporting SGN PRS Consent Submission
	Originator	RiverLinX CJV	Governor Replacement Inlet Stopple Details	
	Location	Greenwich		
	Asset Classification	Multiple Asset Classification		
	Lifecycle	Detailed Design		
Drawn	T. Checked	T. Approved	P. Approved	Authorised
Rev	Date	Purpose / Description		
P01	13/04/20	HGS	SH	---
S2		Fit for Information		
Drawing Number			ST150030-RLC-MAC-06-S10-SKE-HE-0006	Rev.
			P01	



**MATERIALS**

Item No.	Pipe Size	Description	Rating	Spec	Quant
P032	450NB	Pipe - L245GA - Wall Thickness 8mm, Coated To SGN/SP/CW/6	-	GIS / L2	9.6m
P061	50NB	Pipe - L245GA - Wall Thickness 4.5mm, Coated To SGN/SP/CW/6	-	GIS / L2	1.7m
P065	25NB	Pipe - L245GA - Wall Thickness 4mm, Coated To SGN/SP/CW/6	-	GIS / L2	1.2m
B286	450NB	Bend 90° 1½D, Matching Pipe Wall Thickness 8mm, Coated To SGN/SP/CW/6	-	GIS / F7	2
B287	450NB	Bend 45° 1½D, Matching Pipe Wall Thickness 8mm, Coated To SGN/SP/CW/6	-	GIS / F7	3
R069	600NB	Reducer - Concentric - 600NB x 450NB, Matching Pipe Wall Thickness 8mm, Coated To SGN/SP/CW/6	-	GIS / F7	1
V812	50NB	Ball Valve Full Bore - RF / RF - Steel Bodied	NP16	SGN/SP/V/6 Pt.2	8
V862	25NB	Ball Valve Full Bore - RF / RF - Steel Bodied	NP16	SGN/SP/V/6 Pt.2	4
V1169	450NB	Gate Valve Full Bore - RF / RF - Steel Bodied	NP16	GIS / V7	2
F490	600NB	Flange - Weld Neck To Suit 8mm Wall Thickness, Ring Type, Coated to SGN/SP/CW/6	NP16	BS EN 1092-1	1
F529	450NB	Flange - Slip On Raised Face, Coated to SGN/SP/CW/6	NP16	GIS / F7	2
F560	450NB	Flange - Weld Neck To Suit 8mm Wall Thickness, Raised Face, Coated to SGN/SP/CW/6	NP16	GIS / F7	1
F1057	50NB	Flange - Slip On Raised Face, Coated to SGN/SP/CW/6	NP16	GIS / F7	8

**MATERIALS**

Item No.	Pipe Size	Description	Rating	Spec	Quant
F1083	50NB	Flange - Blind Raised Face, Coated to SGN/SP/CW/6	NP16	GIS / F7	4
F1129	25NB	Flange - Slip on Raised Face, Coated to SGN/SP/CW/6	NP16	GIS / F7	4
F1155	25NB	Flange - Blind Raised Face, Coated to SGN/SP/CW/6	NP16	GIS / F7	2
F1818	50NB	Weldoflange Raised Face off 450NB	NP16	GIS / F7	4
F2175	25NB	Weldoflange Raised Face off 450NB	NP16	GIS / F7	2
G036	600NB	Gasket - CNAF To Suit RF Flange	NP16	GIS / F7	1
G044	450NB	Gasket - CNAF To Suit RF Flange	NP16	GIS / F7	4
G116	50NB	Gasket - CNAF To Suit RF Flange	NP16	GIS / F7	16
G132	25NB	Gasket - CNAF To Suit RF Flange	NP16	GIS / F7	8
SB045	-	Studbolts A320 (L7) M33 x 170mm Long Complete With 2H Nuts & Washers To Suit RF Flange	-	BS EN 1515-2	20
SB055	-	Studbolts A320 (L7) M27 x 145mm Long Complete With 2H Nuts & Washers To Suit RF Flange	-	BS EN 1515-2	80
SB145	-	Studbolts A320 (L7) M16 x 80mm Long Complete With 2H Nuts & Washers To Suit RF Flange	-	BS EN 1515-2	64
SB165	-	Studbolts A320 (L7) M12 x 70mm Long Complete With 2H Nuts & Washers To Suit RF Flange	-	BS EN 1515-2	32

NOTE: An Additional 1/4" Has Been Added To The Lengths Quoted In SGN/SP/E/55 To Allow For The Bolt Chamfer

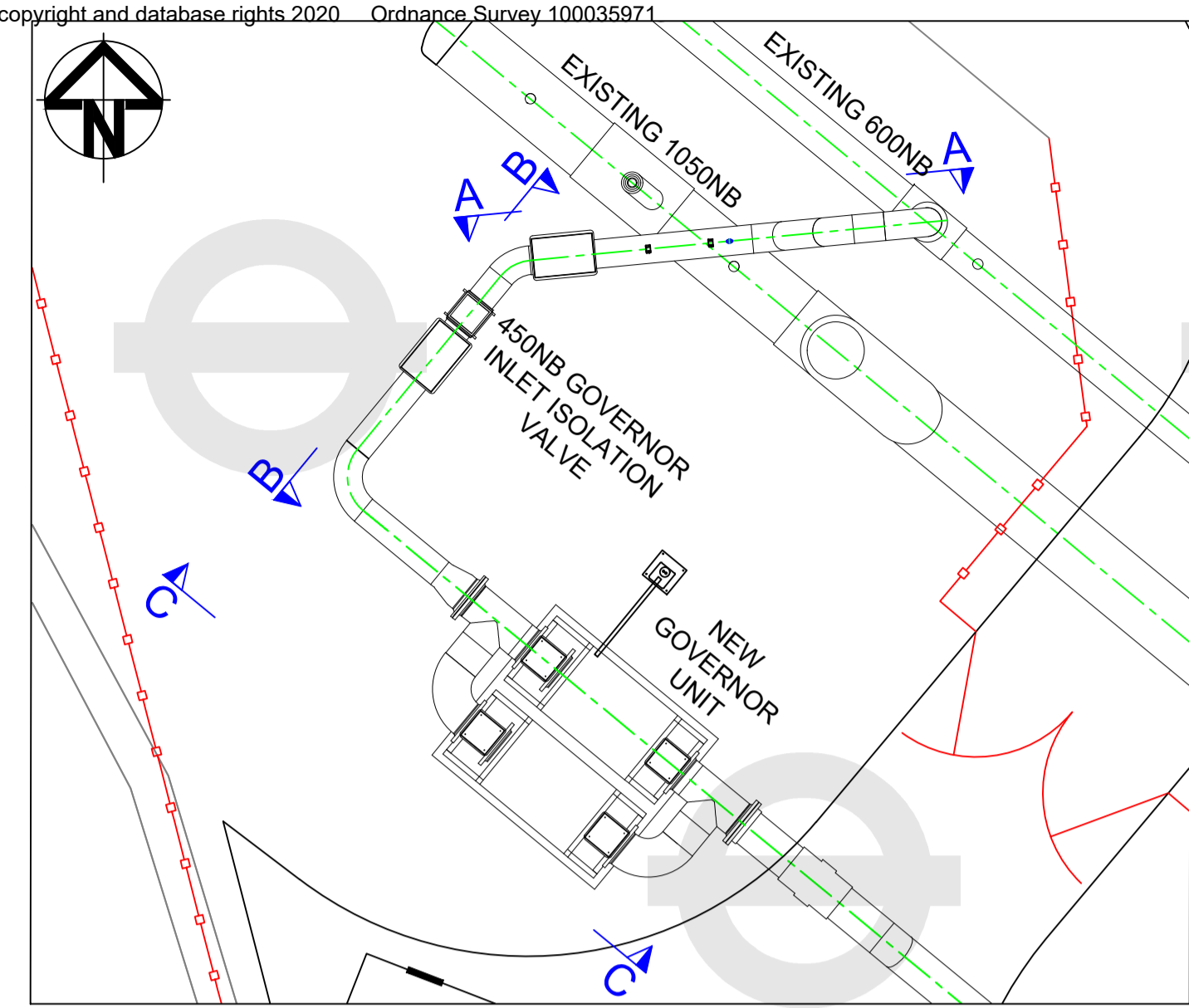

PLAN

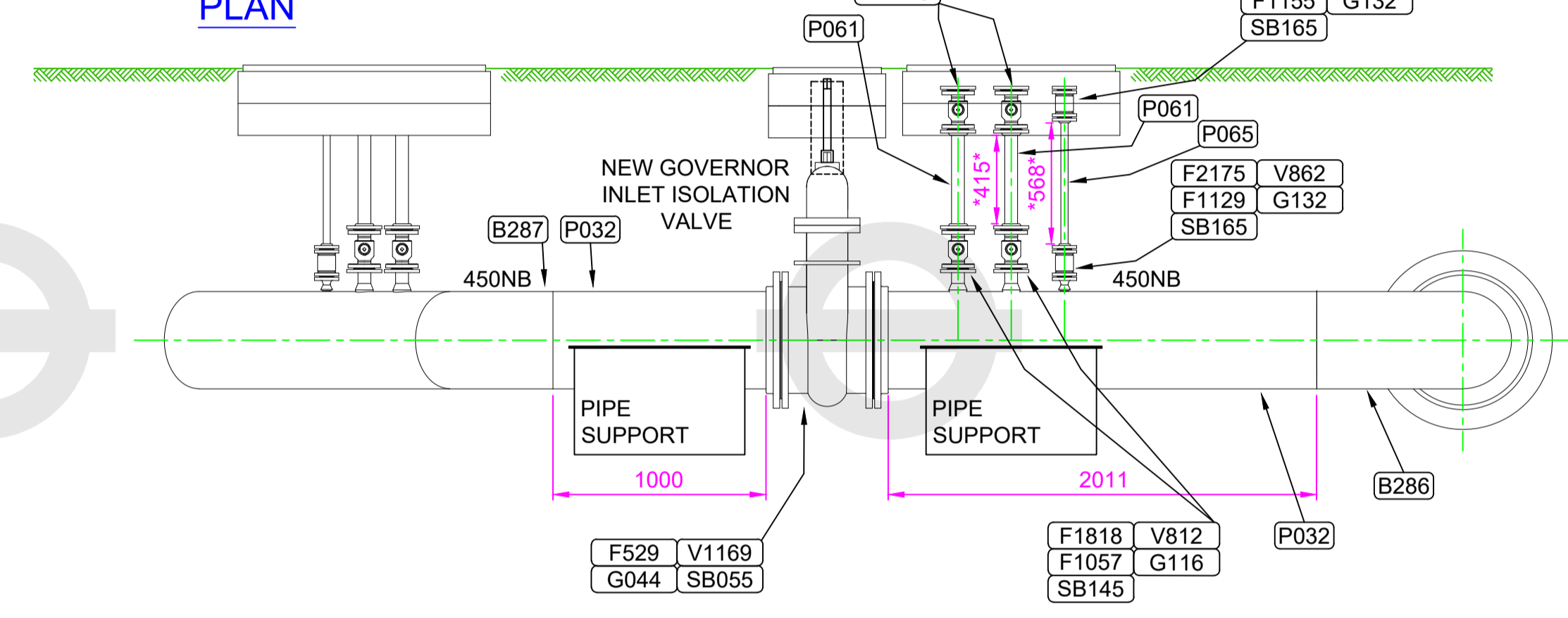

SECTION B - B

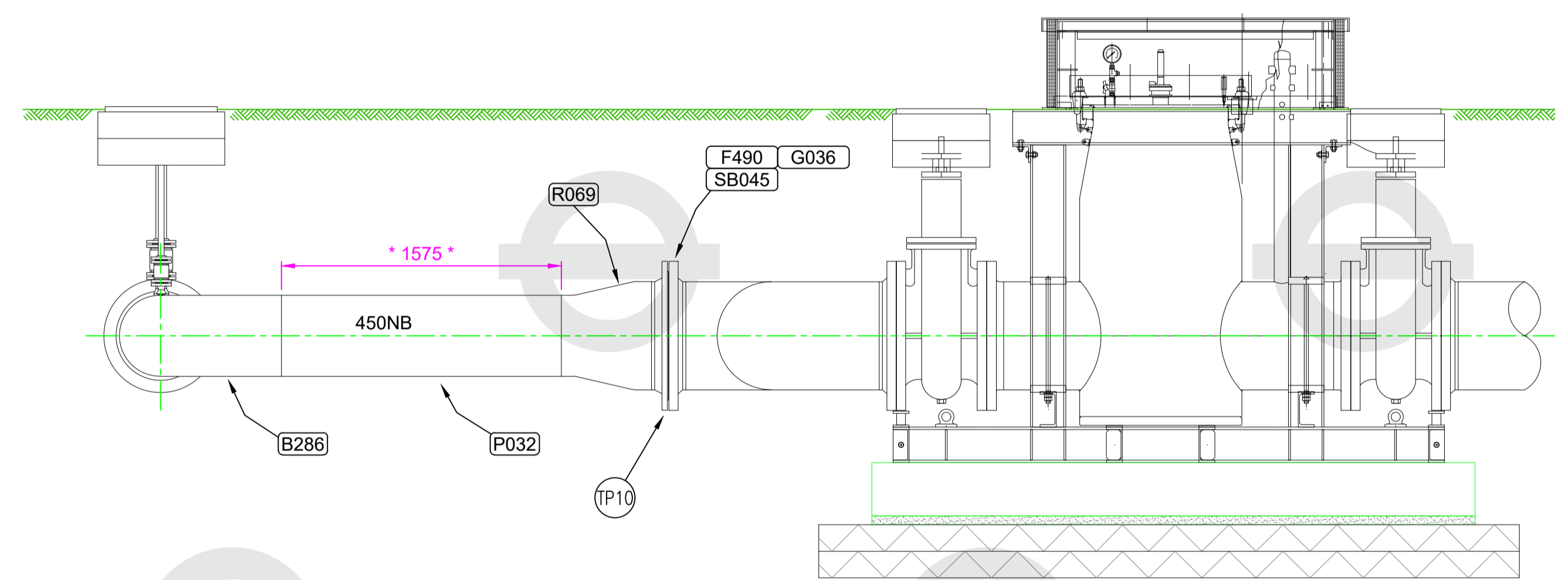

SECTION C - C

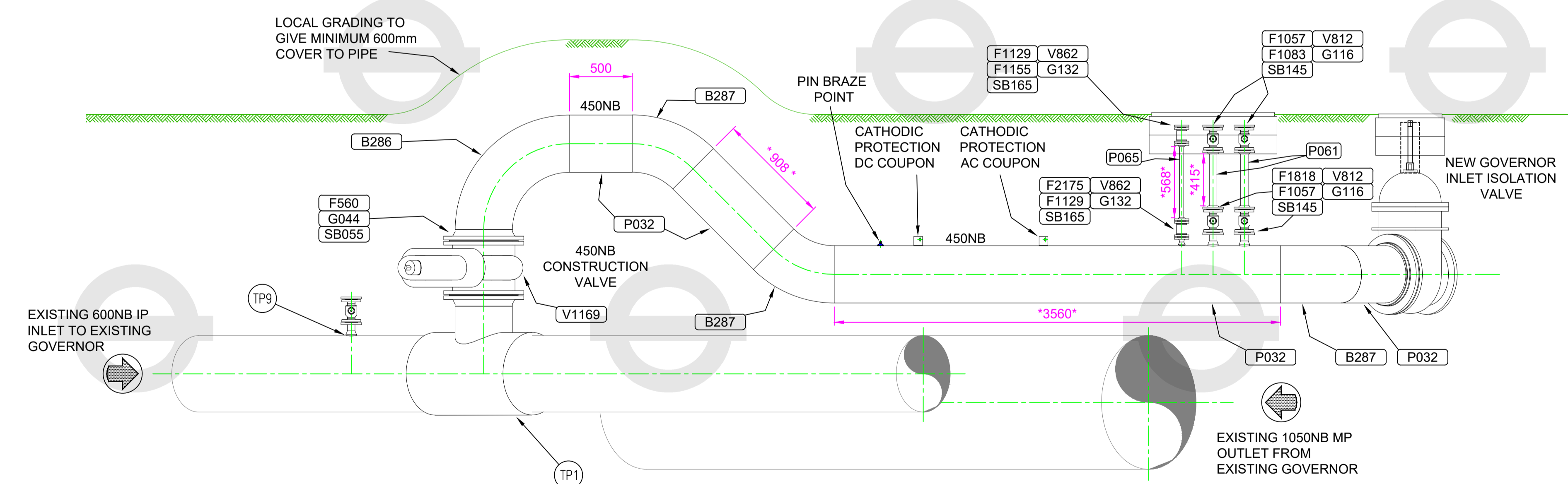

SECTION A - A

PRESSURE TESTING					
Test	Test Section	Pressure (Bar)	Medium	Duration	Specification
Strength test	All Sections	10.5	Hydrostatic	30 minutes	IGEM/TD/13 ED2
Tightness Test	All Sections	7	Pneumatic	15 Minutes	IGEM/TD/13 ED2

NOTES:  
 1. ALL DIMENSIONS ARE IN MILLIMETRES UNLESS OTHERWISE STATED.

Restricted	Project	Silvertown Tunnel	Title	Drawing Supporting SGN PRS Consent Submission	
	Originator	RiverLinX CJV	Location	Greenwich	
	Asset Classification	Multiple Asset Classification	Lifecycle	Detailed Design	
	Suitability	S2	Fit for Information	Drawing Number	
	Drawn	T. Checked	T. Approved	P. Approved	Authorised
	Date				
	Rev				
	P01	13/04/20	HGS	SH	



**MATERIALS**

Item No.	Pipe Size	Description	Rating	Spec	Quant
P061	50NB	Pipe - L245GA - Wall Thickness 4.5mm, Coated To SGN/SP/CW/6	-	GIS / L2	2.4m
P065	25NB	Pipe - L245GA - Wall Thickness 4mm, Coated To SGN/SP/CW/6	-	GIS / L2	1.4m
T1500	1050NB	1050 x 600NB Welded Split Branch Tee RF Flange	NP16	SGN/SP/F/4	1
T1510	1050NB	1050 x 900NB Welded Split Stopple Tee c/w L.O.R. RF Flange, Plug & Blind Flange Kit	NP16	SGN/SP/F/4	1
T1511	1050NB	1050 x 200NB Welded Split Bagging Tee c/w L.O.R. RF Flange, Plug & Blind Flange Kit	NP16	SGN/SP/F/4	1
EC014	1050NB	End Cap - To Suit 12.7mm Wall Thickness Coated To SGN/SP/CW/6	---	ASME B16.9	2
V812	50NB	Ball Valve Full Bore - RF / RF - Steel Bodied	NP16	SGN/SP/V/6 Pt.2	7
V862	25NB	Ball Valve Full Bore - RF / RF - Steel Bodied	NP16	SGN/SP/V/6 Pt.2	2
V1167	600NB	Gate Valve Full Bore - RF / RF - Steel Bodied	NP16	GIS / V7	1
V1510	900NB	Sandwich Valve - Supplied By Drilling Contractor	NP16	---	1
V1512	200NB	Sandwich Valve - Supplied By Drilling Contractor	NP16	---	1
F492	600NB	Flange - Blind, Raised Face, L245GA, Coated to SGN/SP/CW/6	NP16	BS EN 1092-1	1
F1057	50NB	Flange - Slip On Raised Face, L245GA, Coated to SGN/SP/CW/6	NP16	GIS / F7	4

**MATERIALS**

Item No.	Pipe Size	Description	Rating	Spec	Quant
F1083	50NB	Flange - Blind, Raised Face, L245GA, Coated to SGN/SP/CW/6	NP16	GIS / F7	5
F1129	25NB	Flange - Slip On, Raised Face, L245GA, Coated to SGN/SP/CW/6	NP16	GIS / F7	2
F1155	25NB	Flange - Blind, Raised Face, L245GA, Coated to SGN/SP/CW/6	NP16	GIS / F7	1
F1713	50NB	Weldoflange Raised Face off 1050NB - With TOR	NP16	GIS / F7	5
F2119	25NB	Weldoflange Raised Face off 1050NB	NP16	GIS / F7	1
G020	900NB	Gasket - CNAF To Suit RF Flange	NP16	GIS / F7	1
G036	600NB	Gasket - CNAF To Suit RF Flange	NP16	GIS / F7	2
G076	200NB	Gasket - CNAF To Suit RF Flange	NP16	GIS / F7	1
G116	50NB	Gasket - CNAF To Suit RF Flange	NP16	GIS / F7	14
G132	25NB	Gasket - CNAF To Suit RF Flange	NP16	GIS / F7	4
SB025	-	Studbolts A320 (L7) M36 x 190mm Long Complete With 2H Nuts & Washers To Suit 600NB RF Flange	-	BS EN 1515-2	28
SB045	-	Studbolts A320 (L7) M33 x 170mm Long Complete With 2H Nuts & Washers To Suit 600NB RF Flange	-	BS EN 1515-2	40
SB145	-	Studbolts A320 (L7) M16 x 80mm Long Complete With 2H Nuts & Washers To Suit RF Flange	-	BS EN 1515-2	56
SB165	-	Studbolts A320 (L7) M12 x 70mm Long Complete With 2H Nuts & Washers To Suit RF Flange	-	BS EN 1515-2	16

NOTE: An Additional 1/4" Has Been Added To The Lengths Quoted In SGN/SP/E/55 To Allow For The Bolt Chamfer

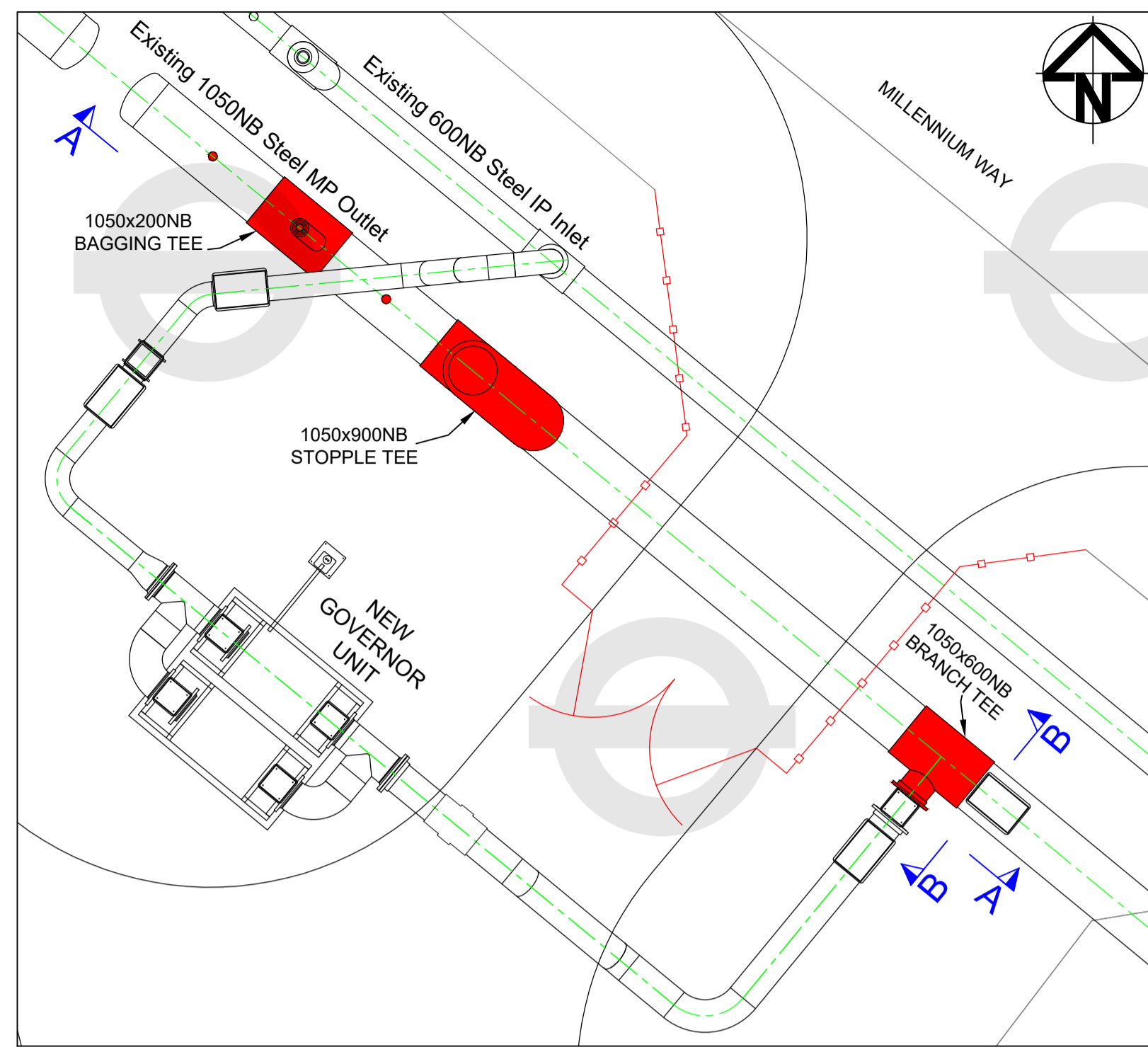

**PLAN**

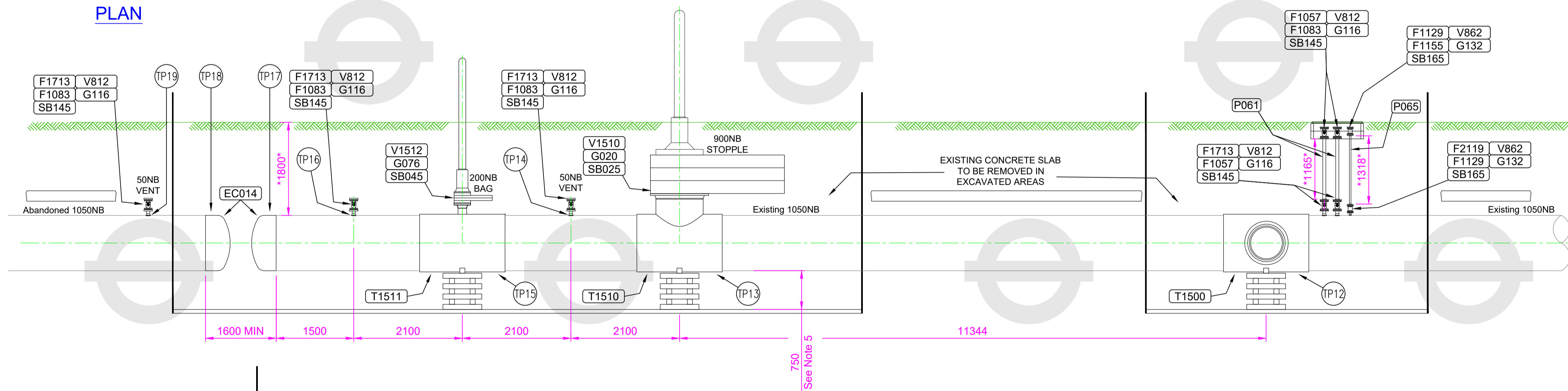

**SECTION A - A**

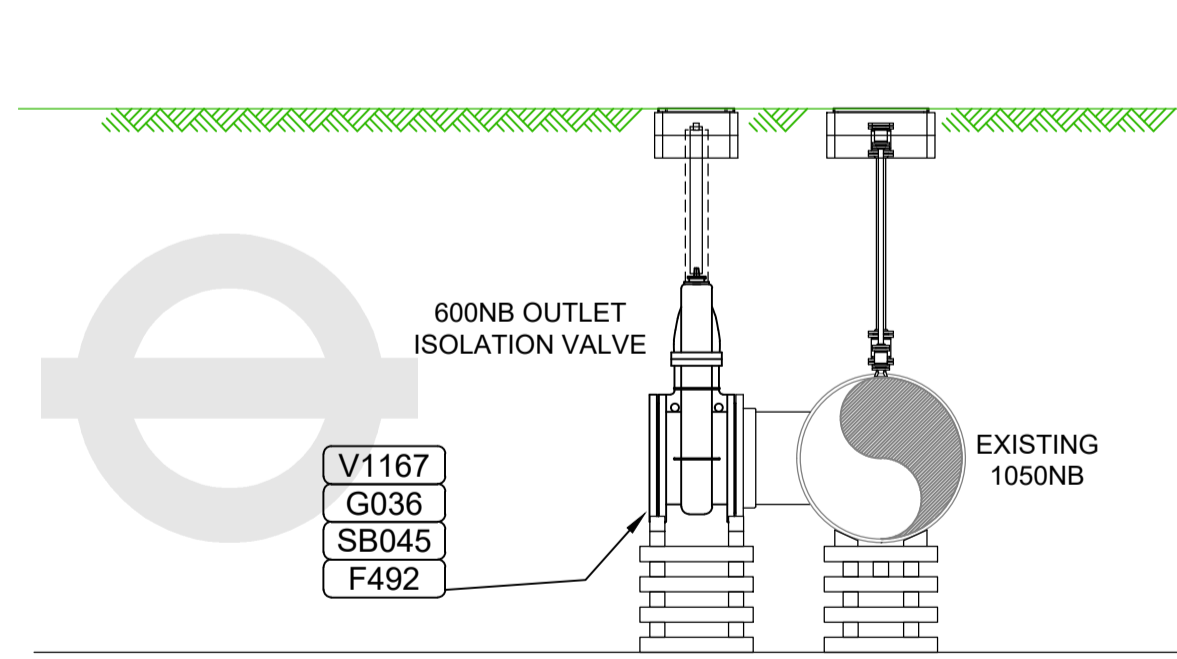

**SECTION B - B**  
PRIOR TO CONNECTING OUTLET PIPEWORK

PRESSURE TESTING					
Test	Test Section	Pressure (Bar)	Medium	Duration	Specification
Strength test	All Tee's	Line Pressure	Pneumatic	30 minutes	IGEM/TD/13 ED2 & T/PMMSL/1

**NOTES:**  
 1. ALL DIMENSIONS ARE IN MILLIMETRES UNLESS OTHERWISE STATED.

Restricted	Project	Silvertown Tunnel	Title	Drawing Supporting SGN PRS Consent Submission	
	Originator	RiverLinX CJV	Location	Greenwich	
	Asset Classification	Multiple Asset Classification	Asset Classification	Asset Classification	
	Lifecycle	Detailed Design	Lifecycle	Detailed Design	
	Suitability	S2	Suitability	S2	
	Fit for Information	Fit for Information	Fit for Information	Fit for Information	
	Drawing Number	ST150030-RLC-MAC-06-S10-SKE-HE-0008	Drawing Number	ST150030-RLC-MAC-06-S10-SKE-HE-0008	
	Rev.	P01	Rev.	P01	
	Drawn	T. Checked	T. Approved	P. Approved	Authorised
	Date				



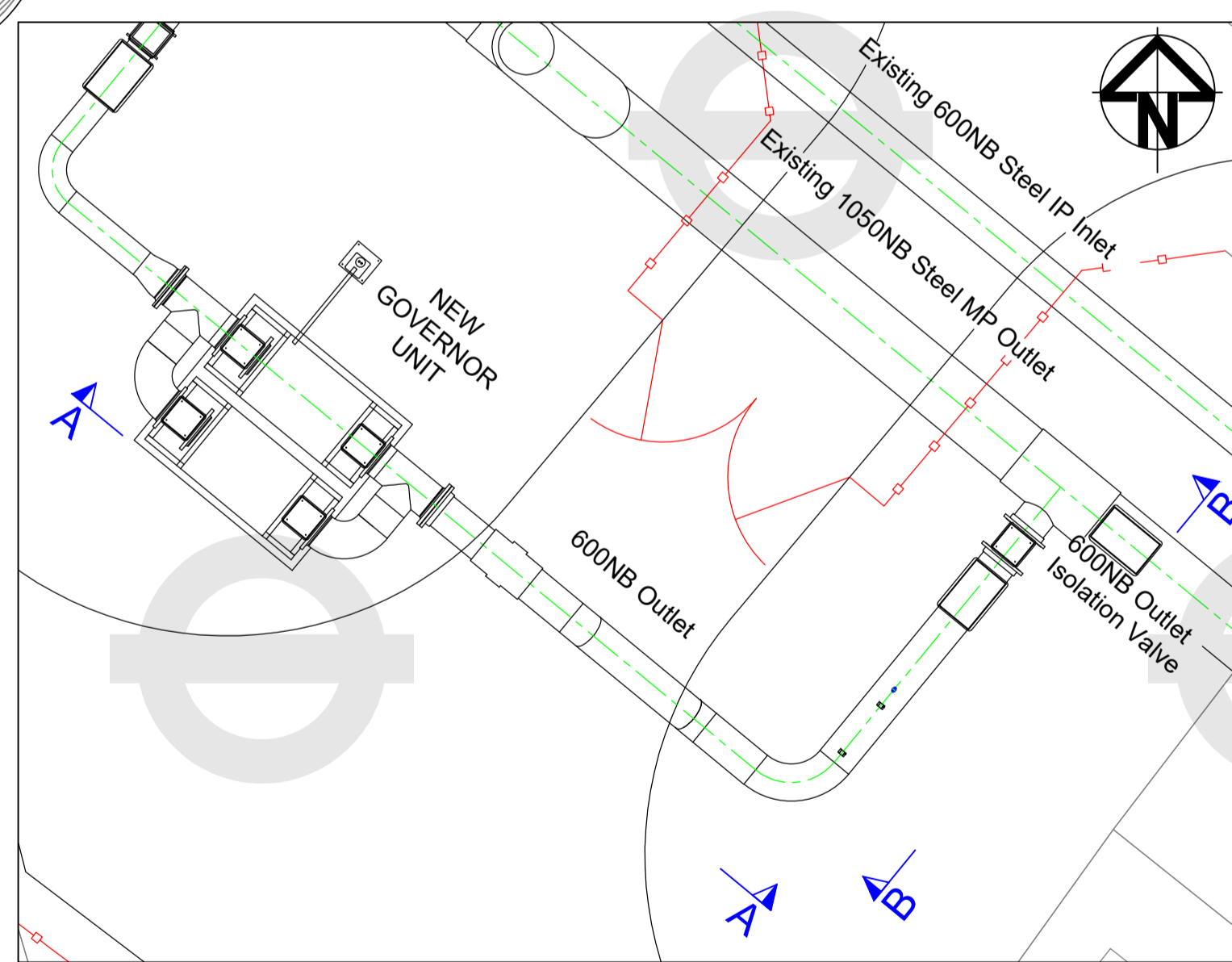
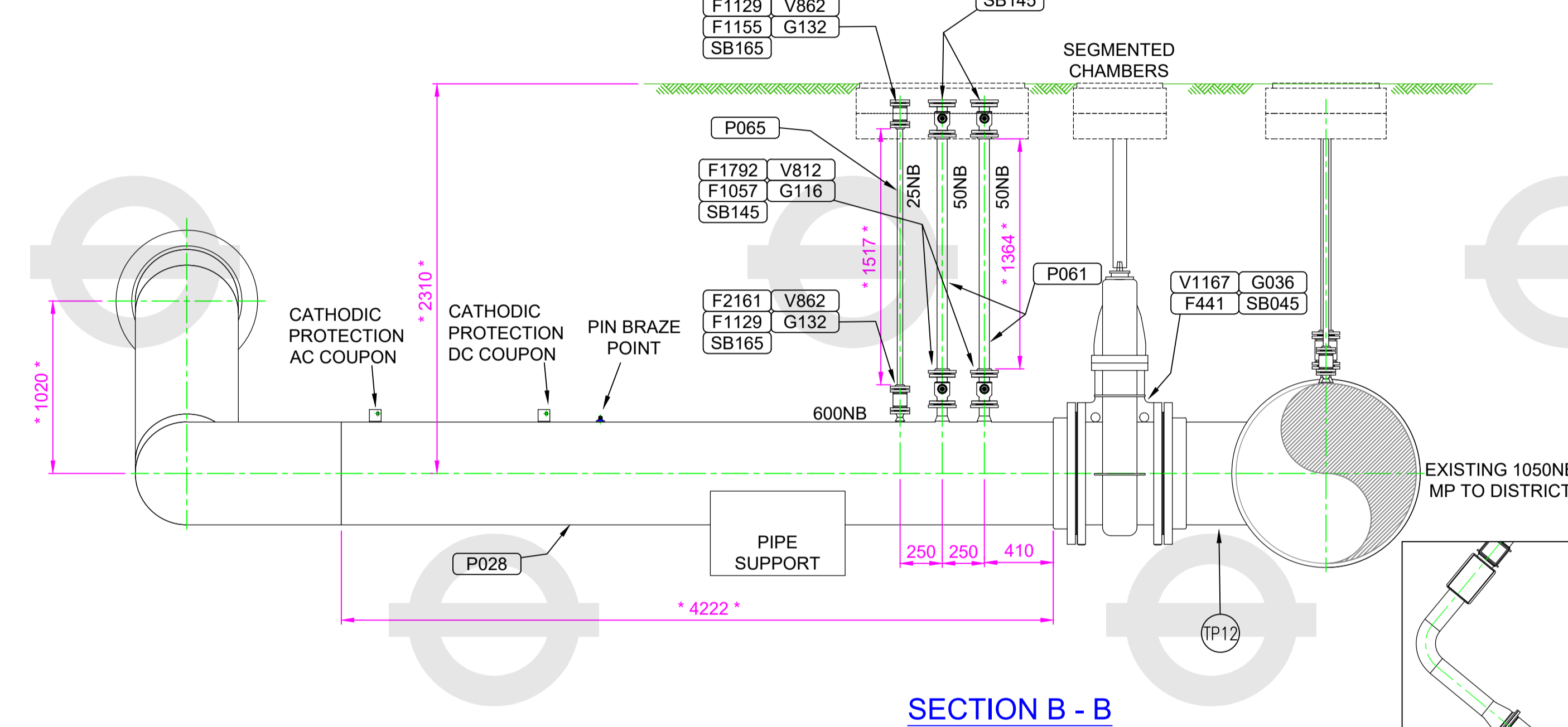
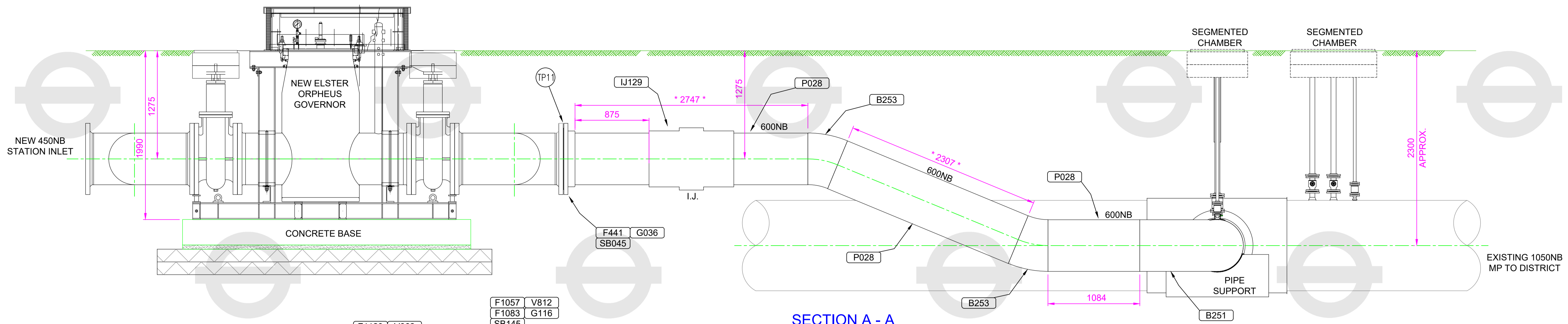

**MATERIALS**

Item No.	Pipe Size	Description	Rating	Spec	Quant
P028	600NB	Pipe - L245GA - Wall Thickness 8mm, Coated To SGN/SP/CW/6	-	GIS / L2	11.5m
P061	50NB	Pipe - L245GA - Wall Thickness 4.5mm, Coated To SGN/SP/CW/6	-	GIS / L2	3m
P065	25NB	Pipe - L245GA - Wall Thickness 4mm, Coated To SGN/SP/CW/6	-	GIS / L2	1.6m
B251	600NB	Bend 90° 1 1/4" D, L245GA, Matching Pipe Wall Thickness 8mm, Coated To SGN/SP/CW/6	-	ASME B16.9	1
B253	600NB	Bend 22 1/2° 1 1/4" D, L245GA, Matching Pipe Wall Thickness 8mm, Coated To SGN/SP/CW/6	-	ASME B16.9	2
V812	50NB	Ball Valve Full Bore - RF / RF - Steel Bodied	NP16	SGN/SP/V/6 Pt.2	4
V862	25NB	Ball Valve Full Bore - RF / RF - Steel Bodied	NP16	SGN/SP/V/6 Pt.2	2
V1167	600NB	Gate Valve Full Bore - RF / RF - Steel Bodied	NP16	GIS / V7	1
F441	600NB	Flange - Slip On Raised Face, Coated to SGN/SP/CW/6	NP16	BS EN 1092-1	3
F1057	50NB	Flange - Slip On Raised Face, Coated to SGN/SP/CW/6	NP16	GIS / F7	4
F1083	50NB	Flange - Blind Raised Face, Coated to SGN/SP/CW/6	NP16	GIS / F7	2
F1129	25NB	Flange - Slip On Raised Face, Coated to SGN/SP/CW/6	NP16	GIS / F7	2
F1155	25NB	Flange - Blind Raised Face, Coated to SGN/SP/CW/6	NP16	GIS / F7	1
F1792	50NB	Weldoflange Raised Face off 600NB	NP16	GIS / F7	2
F2161	25NB	Weldoflange Raised Face off 600NB	NP16	GIS / F7	1
G036	600NB	Gasket - Spiral Wound To Suit RF Flange	NP16	GIS / F7	3
G116	50NB	Gasket - CNAF To Suit RF Flange	NP16	GIS / F7	8
G132	25NB	Gasket - CNAF To Suit RF Flange	NP16	GIS / F7	4
SB045	-	Studbolts A320 (L7) M33 x 170mm Long Complete With 2H Nuts & Washers To Suit RF Flange	-	BS EN 1515-2	60
SB145	-	Studbolts A320 (L7) M16 x 80mm Long Complete With 2H Nuts & Washers To Suit RF Flange	-	BS EN 1515-2	32
SB165	-	Studbolts A320 (L7) M12 x 70mm Long Complete With 2H Nuts & Washers To Suit RF Flange	-	BS EN 1515-2	16
IJ129	600NB	Insulation Joint - To Suit Wall Thickness 8mm	NP16	GIS / E17 Pt.2	1

NOTE: An Additional 1/4" Has Been Added To The Lengths Quoted In SGN/SP/E/55 To Allow For The Bolt Chamfer

PRESSURE TESTING					
Test	Test Section	Pressure (Bar)	Medium	Duration	Specification
Strength test	All Sections	3	Pneumatic	30 minutes	IGEM/TD/13 ED2
Tightness Test	All Sections	2	Pneumatic	15 Minutes	IGEM/TD/13 ED2

NOTES:  
 1. ALL DIMENSIONS ARE IN MILLIMETRES UNLESS OTHERWISE STATED.

Restricted	Project	Silvertown Tunnel	Title	Drawing Supporting SGN PRS Consent Submission				
	Originator	RiverLinX CJV	Location	Greenwich				
	Asset Classification	Multiple Asset Classification	Lifecycle	Detailed Design				
	Suitability	S2	Fit for Information	Drawing Number	ST150030-RLC-MAC-06-S10-SKE-HE-0009			
Rev	Date	Drawn	T. Checked	T. Approved	P. Approved	Authorised	Rev.	P01